



## 2023 ICEW Medical Equipment Buyer's Guide

Discover more: [www.icewmed.com](http://www.icewmed.com)



We touch millions of patients around the world with the products we supply. We have been serving the patients and healthcare providers for over four years. We are one of the leading Healthcare Facility Planning and Equipment sourcing company in Nigeria. ICEW is a single source provider of healthcare equipment and facility planning, including sales, service, repair, parts, refurbishing, and installation. ICEW is making it easier and more affordable for every hospital, clinic, and medical practice to have the very best equipment, supplies and service.

- Guaranteed quality
- Extensive product range
- Competitive Prices
- Prompt delivery
- Exceptional Customer Service
- Same Day Competitive Quote Response
- Ease of ordering

#### **Calibration Service**

We can offer a full calibration service on site for the majority of equipment on your premises including Blood Pressure Monitors, Defibrillators, Scales and Spirometers etc. Certificates of Calibration will be issued for each item. Price on application, contact us for details.

#### **Repairs**

ICEW offers medical equipment service and medical equipment repair services by our highly trained CBET (Certified Biomedical Equipment Technician) and CRES (Certified Radiology Equipment Specialists) biomedical engineers.

#### **Prices**

We will not be beaten on price. Our aim is to supply the highest quality products at the most competitive prices, so prior to your purchase please give us the opportunity to quote.





Proud to be a  
leading supplier  
of medical goods  
for over 4 years

.....

We offer **free**  
**delivery**

Our Mission

ICEW's mission is to provide high quality new and refurbished medical equipment to healthcare facilities worldwide at affordable costs.

Our Goal

ICEW provides a one-stop-shop platform where our customers can compare and contrast among major models and manufacturers. And because we are capable of outfitting entire healthcare facilities, our customers no longer need to purchase from multiple sources saving time and money.

Warranty

All of our products are accompanied by a standard industry warranty and we carry a comprehensive liability insurance guaranteeing our customers peace of mind.

ICEW offers cost-effective equipment solutions backed by our dedicated commitment to quality. It's that peace of mind that makes doing business with us different.

## Section A

- 004** • ACCIDENT & EMERGENCY
- 037** • AUDIOMETRY
- 041** • AUTOCLAVES
- 042** • BAG & CASES
- 047** • CAUTERY & ELECTROSURGERY
- 049** • CONSUMABLES\*
- 050** • CRYOSURGERY
- 052** • DERMATOLOGY
- 058** • DIAGNOSTIC TESTING
- 066** • DOPPLERS
- 072** • EAR, NOSE & THROAT

## Section B

- 076** • ECG MACHINES & ACCESSORIES
- 084** • FAMILY PLANNING & GYNAE
- 088** • FURNITURE
- 201** • INFECTION CONTROL\*
- 202** • LABORATORY
- 224** • LIGHTING
- 239** • LIVING AIDS
- 241** • LOUPES & MICROSCOPES
- 245** • NEBULISERS
- 250** • NURSING HOMES
- 276** • OPHTHALMOLOGY

## Section C

- 288** • OPHTHALM. & OTOSCOPES
- 316** • PHYSIOTHERAPY
- 320** • REFRIGERATION
- 331** • RESPIRATORY
- 339** • SCALES & HEIGHT MEASURES
- 355** • SPHYGMOMANOMETERS
- 374** • STETHOSCOPES
- 381** • SURGICAL INSTRUMENTS\*
- 382** • TEACHING AIDS
- 395** • THERMOMETERS
- 398** • VISION SCREENERS

## Product Highlights



### ZOLL AED 3 Defibrillator

Leads the way with Real CPR Help® technology, providing real-time feedback to guide rescuers in delivering high-quality CPR — [SEE PAGE 18](#)



### Medi-Plinth Care Sure Hospital Ward Bed

A versatile, fully adjustable ward bed with intuitive controls and reliable features for optimum patient comfort and care — [SEE PAGE 110](#)



### Accoson AccoView Diagnostic Sets

Premium quality pocket-sized devices with enhanced features and Fibre Optic, bright LED illumination. — [SEE PAGE 288](#)



### Accoson SA-90 Screening Audiometer

Small, lightweight and durable audiometer for on-site screening of hearing loss. Automatic HSE categorisation of results — [SEE PAGE 37](#)



### HemoCue® Hb 801 System

Optimized for hemoglobin testing in hospital and primary care the unit provides quick, easy access to lab-quality results — [SEE PAGE 59](#)



### Accoson AC300 LED Examination Light

Designed for ease of use this range offers complete freedom of movement allowing for accurate placement of bright LED light — [SEE PAGE 224](#)



### Stalham Tilting Shower Commode

Multifunctional showering commode. Made of strong, rigid materials with no weld joints ensuring its strength and stability — [SEE PAGE 257](#)



### Seca Scale Up Line

Developed for electronic medical records: offering rapid measurement in just seconds with a capacity of up to 300kg — [SEE PAGE 340](#)



### GM Instruments SMART Resuscitation Trainer

Designed to help resuscitate babies or young children: Learn or improve, mask ventilation technique. — [SEE PAGE 382](#)

## Nonin Onyx Vantage 9590 Pulse Oximeter

Finger pulse oximeters with PureSAT® technology quickly and accurately captures SpO<sub>2</sub> and pulse rate measurements – even on patients in motion and with low perfusion. Onyx is the only finger pulse oximeter brand with accuracy and performance supported by published peer-reviewed and clinical studies.

- **Accurate** – Scientifically proven performance in the widest range of patient populations and settings
- **Durable** – Protects against dropping and water spills; allows for thousands of uses in the most demanding environments
- **Efficient** – Up to 6,000 spot checks or 36 hours of continual operation on two AAA batteries
- **Safe** – Built in the USA with lead & latex free construction
- **Versatile** – One unit works on the widest range of patients from paediatric to larger adult patients.
- **Warranted** – Industry leading 5-year 'drop inclusive' warranty
- **Available in four colours** – Black, blue, red and purple
- **Cost Efficient** – Proven accuracy, quality and durability make the Onyx a smart purchase.



**NONIN**

5 Year Warranty

ISO 80601-2-61 Compliant

**AE1084** Oximeter - Black

**AE1085** Oximeter - Blue

**AE1086** Oximeter - Red

**NONIN**



5 Year Warranty

ISO 80601-2-61 Compliant

**AE426** Oximeter + Holster & Soft Carry Case

**AE426.1** Oximeter + Justice Mark II Hard Case

**HCP644** Duracell ULTRA MN2400 (AAA) x4

## Nonin Onyx II 9550 Pulse Oximeter

The Onyx II 9550 fingertip pulse oximeter provides fast, clinically proven SpO<sub>2</sub> and pulse rate readings in a wide range of patients.

- **Small & Lightweight** - Carry the Onyx II anywhere on a lanyard, in a carrying case or in your pocket. It weighs 2oz.
- **Large LED display** - The widest viewing angle available for optimum visibility of patient readings, day or night.
- **Energy Efficient** - A new, turn-off mechanism allows two AAA batteries to provide approximately 6000 spot checks or 36 hours of continuous operation.
- **Paediatric to Adult Finger Sizes** - Accommodates a wide range of finger thicknesses, 0.3-1.0 inch (8 mm to 26 mm).
- **Large LED display** - The widest viewing angle available for optimum visibility of patient readings, day or night.
- **Battery Door** - Enhanced design for easy battery access.
- **Pulse Quality Indicator** - Brilliant, easy-to-see LED provides a quick and accurate assessment of patient readings.
- **Durable** - So rugged and reliable, it can be used in the most demanding environments.

## Nonin 7500 Table Top Pulse Oximeter

Unique low-profile design that enables it to fit easily on a tabletop or into its own carrying case. The 7500 provides a wide range of display indicators that provide reliable readings. Flexible alarm management options include patient security mode and a user-defined default that offers customizable patient settings. Analog output option allows it to interface with other equipment.

- Full range of sensors are available for adults to neonates, spot checks to long-term
- Extremely durable unit for infants through to adults
- Reliable & Accurate, using proven Nonin PureSAT™ SpO<sub>2</sub> tech
- Intuitive front-mounted controls can quickly be mastered
- Large LED display is easily read from a distance
- Unique Pulse Quality Indicator, assessing of signal quality
- Adjustable audible and visual SpO<sub>2</sub> and pulse rate alarms
- 12 hour built-in NiMH battery or mains power (Requires cable)
- 72 hours of non-volatile memory



**NONIN**

**AE1100** Nonin 7500 Table Top Pulse Oximeter

**AE1100.1** Power Cable For Nonin 7500 Inc. AC Adaptor & Mains Cable

## Nonin 2500 PalmSAT Pulse Oximeter

Complete with adult sensor and free carry case

PalmSAT 2500 Series handheld pulse oximeters are designed to accurately assess oxygen saturation (SpO<sub>2</sub>) and pulse rate. Compact size, ease of operation, and optional alarms in the 2500A make the PalmSAT series suitable for portable monitoring regardless of patient location. Small yet versatile, PalmSAT 2500 pulse oximeters are Certified Airworthy by the U.S. Air Force.

- **Power Options** – Can run on (4) AA batteries, rechargeable batteries, or AC power with charger stand
- **U.S. Military Certified** – The 2500 Series pulse oximeters have U.S. Army and U.S. Air Force aeromedical certifications
- **Alarm Option** – Model 2500A features amber and red lights to indicate medium or high priority alarms
- **Powerful Memory** – for 72 Hours (4 sec. interval) of Data
- **Efficient** – 80 Hours Typical Operation on batteries, 40 Hours Rechargeable (With 90min Fast recharge)
- **Flexible Power Options** – 4x AA Batteries, Rechargeable NiMH Batteries or AC Power with Optional NiMH Charge stand
- **LED Display** – Large Tri-Colour for Maximum Visibility
- **Compact** – 7.4 oz Unit for Easy Handling and Portability
- **Simple** – Two Button Operation and Integrated Self-Test
- **Warranty** – Main Unit, 5 years drop – Sensor for 2 years

<b>AE892</b>	2500 PalmSAT with Memory
<b>AE009</b>	2500A PalmSAT with Memory & Alarm
<b>AE009.6</b>	Charger Stand for Nonin PalmSAT Monitor



## Fingertip Pulse Oximeter (OLED Screen)

The perfect choice for on-the-spot SpO<sub>2</sub> and pulse rate testing

The lightweight and small size means it can be easily carried in your pocket. Features OLED display with adjustable brightness. The oximeter fits a wide range of finger sizes comfortably and the device switches off when a finger is removed from the unit for more than 8 seconds.

- Dual colour OLED display
- SpO<sub>2</sub>, Pulse Rate & Pleth Waveform
- 10 brightness levels with 6 display modes
- Auto power off after 8 secs
- Suitable for adults and paediatric patients
- Simple operation, light weight and convenient to carry
- Power consumption: Less than 30mA
- Requires 2 AAA alkaline batteries (supplied)
- Approximately 30 hours of battery life



<b>AE601</b>	Fingertip Pulse Oximeter (OLED Screen)
<b>AE1038</b>	Case for Fintertip Fingertip Pulse Oximeter

## Chocimed Finger Pulse Oximeters

For use in checking patient blood-oxygen saturation (SpO<sub>2</sub>) levels and pulse rate.

- Available in your choice of Bright LED or Dual Colour OLED display, with two colours available for each
- Small & lightweight design ( total 28g without batteries )
- Displays SpO<sub>2</sub>, PR, Pulse bar
- Low power consumption, automatically power off
- Battery-low indicator
- **OLED Pulse Oximeters also feature:** Six display modes, adjustable brightness and Plethysmogram
- 2 AAA alkaline or rechargeable batteries
- Accommodates the widest range of finger sizes from pediatric to adult



<b>AE1768</b>	MD300-C1F – Bright LEDs Display (Black)
<b>AE1768.3</b>	MD300-C19 – Bright LEDs Display (Blue)
<b>AE1768.1</b>	MD300-C23 – Dual colour OLED display (Purple)
<b>AE1768.2</b>	MD300-C26 – Dual colour OLED display (Green)
<b>AE1768.4</b>	MD300-C52 – Paediatric Pulse Oximeter
<b>AE1768.5</b>	MD300-C12 – Adult Pulse Oximeter

## Spectro2™ Pulse Oximeter Series

Delivering accurate, trustworthy readings across a range of patient care settings, even during motion or in low perfusion.

### Confidence in results

- PI (Pulse amplitude Index) Indicator helps identify and maintain a good test sit

### On-Board Sensor Storage

- Protects sensor when not in use
- Reduces damage and minimizes unnecessary replacement costs with a Sensor that is always ready and available

### Versatility with multiple sensors

- Compatible with all BCI® reusable and disposable sensors
- Nellcor® sensor compatibility (Models 20 & 30)

### One of the largest displays on the hand-held market

- At-a-glance patient assessment
- Easy to view from wide angles
- Simple interface easily understood
- 50% larger LEDs than comparable hand-held devices

## Spectro2™ | 20 Oximeter

### Reliable spot check results

even challenging care settings:

- Low perfusion performance
- Motion tolerance
- Intuitive, ergonomic design

### Clinical Applications:

For higher acuity patients, or for use during ambulatory situations.

- Inter- and Intra-hospital transport
- Triage
- Patient tremors
- Unstable patients



**AE005** Oximeter System with Adult Spot Check Finger Sensor

**AE006** Oximeter System with Adult Finger Sensor

## Spectro2™ | 30 Oximeter

### Dependable continuous monitoring with the flexibility to perform in virtually any clinical setting

- Low perfusion performance
- Motion tolerance
- Multiple operating modes
- Visual, audible and remote alarms

### Clinical Applications:

- Monitor for efficacy of respiratory treatments.
- At-risk patients
- Sleep screening
- Post anaesthesia recovery
- Analgesics monitoring



**AE007** Spectro2 |30 Oximeter System

### Accessories available for the Spectro2™ series:

**AE014** Protective Glove - Blue

**AE015** Protective Glove - Green

**AE016** Protective Glove - Red

**AE017** Protective Glove - Yellow

**AE001.2** Oximetry Finger Probe (Reuseable) - Single

**AE001.3** Paediatric Disposable Finger Probe 15.45kg - 10pk

**AE001.4** Neonate Disposable Finger Probe < 3kg - 10pk

**AE001.5** Infant Disposable Finger Probe for BCI 3401 3.15kg - 10pk

**AE001.6** Adult Spot Check Sensor (Reuseable) - Single

**AE001.7** Adult Disposable Oximetry Finger Probe - 10pk

**AE001.8** Oximetry Ear Probe (Reuseable) - Single

**AE002.1** Probe Oximetry Wrap Infant (Reuseable) - Single

**AE002.2** Comfort Clip Oximetry Finger Sensor (Reusable) - Single

**AE002.6** Universal Y Oximetry Probe (Reuseable) - Single





## PM-60 Pulse Oximeter

A miniature, lightweight device capable of spot-check and continuous monitoring of SpO2 and pulse rate. You can determine the capabilities and performance, depending on the operational mode you choose.

For simple vital signs checks, spot-check mode offers basic functions including auto-assign of patient ID, alarm suppression state and auto-standby and power-off features.

For longer-term monitoring, continuous mode offers manual entry of unique patient ID's, alarm management and pleth waveform display. If pulse oximetry varies from day-to-day, or hour-to-hour, the PM-60 is the ideal device for your needs.

- Suitable for adult, paediatric and neonatal patients
- High resolution 2.4" colour LCD Display
- Two selectable working modes: Spot check and Continuous
- Adjustable audio and visual alarms
- Real time data transfer via infrared
- Batteries to support up to 36 hours of continuous use
- **Supplied with:** Adult Reusable SpO2 Finger Sensor and three coloured protective covers (Yellow, Orange & Blue)

**AE1654** PM60 Pulse Oximetry Monitor, SpO2

**AE1655** PM60 Pulse Oximetry Monitor, SpO2 with charger



## seca mVSA 535 Vital Signs

Designed to make this task as easy and efficient as possible. Staff at any level can operate the spot-check monitor due to its intuitive touch screen and self-explanatory user interface.

The vitals capture is simple and fully validated for HL7 and many EMR systems. Connectivity to seca scales and measuring stations due to seca 360° proximity is also a plus as well as the unique seca EQ BP® technology.

The seca mVSA fits perfectly into your existing workflows and frees up resources improving patient care.

- Easy to operate spot-check monitor to capture all basic routine patient vitals in less than 60 seconds
- Quick and accurate BP measurement in under 20 seconds
- Configurable seca EQ BP® average mode (BP30) provides true screening of hypertension
- seca scale connectivity through seca 360° proximity: One integration interface for all seca devices
- World-class service program with no downtime
- Long lasting battery, up to 150 measurements on one charge
- Convincing data storage: All measurements stored and available for later processing
- EMR-validated: transmit measured data directly to any electronic medical record system or printer

**Monitor supplied with:** power cable, Blood pressure cuff (reusable) size M, SpO2 cable extension, SpO2 SoftFlap® sensor (clip for adults) and G3 temp device with probe covers

**Also available:** Adjustable height seca roll stand

**AE1549** 535 Vital Signs Analyser with NIBP, seca SpO2, Tympanic Temp

**AE1550.1** seca 535 Roll Stand with castors & storage



## Nellcor™ PM100N Patient Monitoring System

Flexible, Compact and Intuitive. The system provides quick access to real-time patient respiratory status information and trending data.

- Monitors neonates to adults and Measures SpO<sub>2</sub> from 1–100%
- Also Measures pulse rate from 20 to 250bpm
- Displays plethysmographic waveforms, pulse amplitude and real-time SpO<sub>2</sub> and pulse rate data
- 96-hour trend memory with data captured every four seconds for quick review of changes in patient status
- Includes SatSeconds™ alarm management, a clinician-controlled feature that is proven to reduce nuisance alarms
- Password protected homecare and sleep study modes
- Both homecare and sleep study modes meet **IEC 60601-1-11** for home health equipment to promote the safe and effective use of the monitor by lay users in the non-hospital setting.
- **Includes a disposable Sensor sample pack**
- **Dimensions & Weight:** 8.2 x 25.5 x 15.5cm / 1.5 kg



<b>AE13.1</b>	PM100N Patient Monitoring System
<b>AE608</b>	OxiMax™ Durasensor - Adult
<b>AE609</b>	OxiMax™ Dura-Y Sensor
<b>AE610</b>	OxiMax™ Paediatric Spot Check Clip
<b>AE611</b>	OxiMax™ Oxiband Sensor (Reusable) - Adult/Neonatal
<b>AE612</b>	OxiMax™ Oxiband Sensor (Reusable) - Paediatric/Infant

## Nellcor™ PM10N Portable Patient Monitoring System

A convenient, handheld monitor that is capable of spot-checks and continuous monitoring in hospital, mobile and home uses.

Incorporating Nellcor digital signal processing technology to deliver accurate, reliable SpO<sub>2</sub> and pulse rate values even during low perfusion and signal interference, including patient motion. The monitoring system includes a vivid 3-inch color LCD screen and connectivity to analytic tools etc.

- Small, lightweight, ergonomic handheld monitor
- Supports a robust data set, including real-time SpO<sub>2</sub> and PR values, SatSeconds alarm management, pleth waveform, blip bar and tabular trend data
- Sleep Study Mode, dim the LCD display and silence alarms to prevent disruption of patients' sleep
- Nellcor™ advanced signal processing technology delivers reliable operation even in difficult monitoring conditions
- LoSat expanded accuracy range (60% to 100% SpO<sub>2</sub>) when used with Nellcor™ adhesive sensors with OxiMax™
- Compatible with the complete line of Nellcor single-patient-use, reusable and specialty sensors with OxiMax™ technology
- 80 hours of data storage capability
- Supports wired data export to an external personal computer for data analysis and printing functions
- No sensors are supplied with this product



<b>AE1463</b>	PM10N Portable Patient Monitoring System
<b>AE608</b>	OxiMax™ Durasensor - Adult
<b>AE609</b>	OxiMax™ Dura-Y Sensor
<b>AE610</b>	OxiMax™ Paediatric Spot Check Clip
<b>AE611</b>	OxiMax™ Oxiband Sensor (Reusable) - Adult/Neonatal
<b>AE612</b>	OxiMax™ Oxiband Sensor (Reusable) - Paediatric/Infant

### PM10N Monitoring System Covers:

<b>AE1463.1</b>	Protective Cover - Pink
<b>AE1463.2</b>	Protective Cover - Blue
<b>AE1463.3</b>	Protective Cover - Navy
<b>AE1463.4</b>	Protective Cover - Green
<b>AE1463.5</b>	Transport Protective Cover



## Nonin 3150 BLE WristOx2 Pulse Oximeter

Engineered with Nonin Medical's proven PureSAT® SpO2 technology, the WristOx2, Model 3150 delivers highly accurate readings in the widest range of patient populations and settings.

Ideal for applications including ambulatory monitoring, remote wireless monitoring and overnight studies—providing the versatility and reliability that clinicians expect from Nonin.

A ergonomic design and Bluetooth® wireless technology eliminate inconvenient bulky cables and provide patients with increased comfort and independence.

- Functionality for real-time display on iOS devices via the app
- Design Updates – Small size wears like a watch with large display screen and enhanced sensor connector design
- Software Support – Advanced features such as 6 Minute
- Walk Test (6MWT) or overnight sleep reporting available when used with nVISION® data management software
- Convenient Data Transfer – Transfer data securely to nVISION® via Bluetooth wireless or USB connection
- WristOx Sensor Line – The WristOx2 sensors are exclusively designed for use with Model 3150
- Versatility – Model 3150 is an ideal choice for multiple applications where small, portable oximetry is needed
- Powerful Battery – 48 hours of battery life (non-Bluetooth), 24 hours with continuous Bluetooth using two AAA batteries
- Simple Data Verification – Memory Volume Indicator Mode provides verification of recorded data.



 3 Year Warranty

Accident & Emergency

**AE1785** Nonin 3150 with Bluetooth Low Energy (BLE) and Adult Sensor

**AE1786** Nonin Reusable Flex Sensor - Adult (0.3m Cable)

**AE1787** Nonin Finger Clip Sensor - Adult (0.3m Cable)

**AE1788** Wristband - Reusable, 25cm (10")

**AE1789** Nonin nVision PC Software for Monitor

**AE1790** Data Download Cable with USB

**AE1791** Black Carrying Case for WristOx Monitors & Accessories

## Smartsigns® MiniPulse

Ideal for both spot checking and continuous monitoring of Adult, Paediatric and Neonatals.

### Feature rich functionality

The simple user interface and one of the largest displays in its class provide easy view of patient status. The large LED display allows the patient's saturation level, pulse rate and signal quality to be viewed from wide angles.

### Battery life, life costs and value for money

Both models are powered by four AA cells and are capable of delivering more than 60 hours of continuous monitoring; this high capacity capability and range of affordable sensors and practical accessories results in a very low cost of ownership.

### Product Sensors/Probes

Each model will be supplied with at least one customer specified reusable sensor at the time of purchase, e.g. Adult or Paediatric

**AE642** MP1 (Please specify probe)

**AE643** MP1R - Rechargeable (Please specify probe)

Item	MP1	MP1R
Desk Stand	Optional	N/A
Desk Stand with Charger	N/A	Optional
4x AA Alkaline Cells	<b>Standard</b>	N/A
4x AA NiMH Rechargeable Cells	N/A	<b>Standard</b>
Wall Cube/Power Supply	N/A	<b>Standard</b>
Reusable Sensor	<b>Standard</b>	<b>Standard</b>
Multi-lingual Instruction CD	<b>Standard</b>	<b>Standard</b>
Weatherproof Carry Case	Optional	Optional
Pole Clamp	Optional	Optional



**HUNTLEIGH**

 5 Year Warranty

### Re-usable SpO2 Sensors

**AE643.1** 5' SpO2 Extension cable

**AE643.2** Ear sensor

**AE643.3** Infant Wrap sensor

**AE643.4** Neonatal Wrap sensor

**AE643.5** Universal Y sensor

**AE643.6** Paediatric finger sensor

**AE643.7** Adult reusable SpO2 sensor

**AE643.8** Neonate Tape Attachment – 50pk

**AE643.9** Infant Tape Attachment – 50pk

### Disposable SpO2 Sensors

**AE643.10** Adult Finger Sensor – 10pk

**AE643.11** Paediatric Finger Sensor – 10pk

**AE643.12** Neonatal Finger Sensor – 10pk

**AE643.13** Infant Finger Sensor – 10pk

## Huntleigh Smartsigns Compact 300 Series

The SC300 is a mains and battery operated compact SPOT check vital signs monitor. This powerful flexible platform offers healthcare professionals a range of measurements which includes non-invasive blood pressure, pulse rate, pulse oximetry and a wireless tympanic temperature option.

Equipped with a durable, long-life 12hr battery pack, the SC300 is able to be used in a large variety of healthcare settings with adults, paediatrics and even newborns.

Patient status is displayed on the 6" colour coded digital display enabling clinicians to make critical decisions at the point of delivery.

- Clear 6" digital display with large easy read information.
- Wireless temperature option (up to 10m range).
- 50 Measurement memory.
- Minimum number of controls.
- Long life batter pack (12hrs).
- Choice of SpO2 technologies: Own Brand / Nellcor.
- Integrated carry handle
- **Further accessories and cuffs are available**

**AE1551** SC300 with NiBP, Pulse and SpO2

**AE1552** SC300 with NiBP, Pulse, SpO2 and Temperature

**AE1735** Adult NIBP Cuff - 20-28cm

**AE1559** Adult NIBP Cuff - 25-35cm

**AE1557** Adult NIBP Cuff - 33-47cm

**AE1738** Ped NIBP Cuff - 18-26cm

## HUNTLEIGH

 Made in the UK

 5 Year Warranty



**AE1553** SC300 with NiBP, Pulse and SpO2 (Nellcor)

**AE1554** SC300 with NiBP, Pulse, SpO2 (Nellcor) and Temperature

**AE1737** Infant NIBP Cuff - 10-19cm

**AE1556** Fixing Kit - For Wall mount and Roll stand

**AE1555** GCX Roll stand (with integrated storage basket and 5 castors)

**AE1555.1** GCX Wall mount

## Huntleigh Smartsigns Compact 500

From its attractive design to its intuitive screen layout, the SC500 maximises the care givers' productivity and enhances department workflow.

Using the SC500 smart interface, users have the choice of selecting a large numerical display or switching to a more traditional two waveform layout to display patient status, capable of delivering short, medium and long term monitoring.

With its flexible platform, the SC500 base configuration provides users with a standard set of monitoring capabilities: BP, Pulse Rate and Oxygen Saturation. If additional vital signs require monitoring, users can select to add optional modules as needed.

- Clear 8" digital Display with integrated touchscreen
- Integrated carry handle for portability
- One touch NiBP Start/Stop button
- Long life 8 hour Battery
- 200 Measurement storage and transfer, recall facility
- National Early warning scoring system (MEWS & NEWS2)
- User programmable three level alarm function
- Bi-directional connectivity to CMS
- Suitable for adult, paediatric and neonatal patients
- **Further accessories and cuffs are available**

**AE1559** Adult NIBP Cuff - 25-35cm

**AE1557** Adult NIBP Cuff - 33-47cm

**AE1558** Adult NIBP Cuff - 46-66cm

**AE1738** Ped NIBP Cuff - 18-26cm

**AE1737** Infant NIBP Cuff - 10-19cm

## HUNTLEIGH

 Made in the UK

 2 Year Warranty



**AE1869** SC500 Base Unit with BP, SpO2 and Pulse Rate

**AE1869.1** SC500 ECG (3 Lead config.) Addition

**AE1869.2** SC500 Nellcor Oximax SpO2 Addition

**AE1869.3** SC500 Temperature (Tympanic) Addition

**AE1869.4** SC500 Integrated printer Addition

**AE1870** Adult soft tip sensor (Oximax compatible)

**AE1871** Paediatric soft tip sensor (Oximax compatible)

**AE1872** Infant soft tip sensor (Oximax compatible)

**AE1873** Neonatal silicone wrap sensor (Oximax compatible)

**AE1869.5** SC500 Light Duty roll stand (with storage basket and castors)

## ePM Patient Monitors

The ePM has been designed to meet the growing needs of caregivers, to enhance the efficiency and safety of their care.

- Compact version (fixed parameters) and a Modular version (expandable parameters) available
- Hi-res touchscreen with 170° viewing angle and gesture control
- Accurate and reliable parameters including 3/5 lead ECG, respiration, 2 ch temperature, SpO2, NIBP, Arrhythmia Analysis and ST Segment Analysis
- British Hypertension Society (BHS) validated NIBP
- Extensive data storage capability for trend data, alarms, events, NIBP measurements
- Suitable for adult, paediatric, and neonate patients
- Validated for cleaning with 49 disinfectants, including Clinell
- Mounting solutions available, with quick release mechanism
- A range of mounting options are available (bed, stand & wall)

**Supplied with:** ECG Trunk Cable, ECG Lead wires, 10 Electrodes, SpO2 Interface Cable, Adult Reusable SpO2, Finger Sensor, NIBP Hose, NIBP Cuff & Temperature probe.

**AE1858** ePM 10 Compact – Full Package

**AE1859** ePM 12 Modular – Full Package



## Mindray VS9 Vital Signs Monitor

The VS9 workstation goes beyond vital signs to improve patient care, releasing the full potential of bedside assessments from inpatient admissions to spot-checks. With fast, comprehensive parameters, flexible workflow options and scalable connectivity, clinicians are empowered to deliver high quality bedside care to each and every patient.

- 15-second blood pressure readings with TrueBP™
- Three SpO2 options - Mindray, Masimo SET and Nellcor
- Comprehensive range of parameters including NEWS2
- Input up to 30 manual parameters
- 10 flexible workflow profiles for increased clinical efficiency
- Vivid 10" touchscreen for fast and intuitive operation
- Connectivity with central monitoring & 3rd party EPR systems
- Validated with leading UK cleaning agents, including Clinell®
- Up to 8hr battery life with status indicator when on standby
- Remote maintenance with M-IoT Device Manager (optional)
- **Please see our website for further information & accessories**
- **Optional thermometry:** Genius™ 3 tympanic, Exergen TemporalScanner™, HeTaiDa™ contactless forehead or SmarTemp™ oral/axilla
- **Optional TrueResp™ technology:** allows respiration rate to be recorded by the SpO2 finger sensor



**AE1874** Mindray VS9 Vital Signs Monitor

## Mindray VS600 Vital Signs Monitor

The ideal portable vital signs monitor, allowing caregivers to confidently perform all the basic clinical functions necessary during periodic spot-checks in low-acuity areas of the hospital.

Designed to greatly reduce the time needed for vital signs checking, allowing you to focus even more on your patients. Suitable for adult, paediatric and neonatal patients, the device is compact and lightweight with a clear display.

- Measures BP, pulse, SpO2 and temperature (optional)
- British Hypertension Society (BHS) A/A validated BP measures
- PI (Perfusion Index) provides caregivers with an indication of the reliability of SpO2 measurement
- Suitable for adult, paediatric and neonatal patients
- High definition, bright display for easy viewing
- Easy access to all functions through a four-button keypad
- Highly mobile spot-check device, weighing only 1.7 kg
- Hi-capacity Li-ion battery provides more than 22 hours of continuous monitoring
- Trusted temperature measurement provides fast oral temperature readings (optional)
- **Please see our website for further information & accessories**



**AE1710** Mindray VS600 Vital Signs Monitor

## NC3 Vital Signs Monitor

The NC3 Vital Signs Monitor is the ideal solution for use in the GP's Office, Community Clinic, Outpatients Department or in General Wards.

This small, lightweight and durable monitor features a 6inch colour screen and a rechargeable Li-ion battery.

- The whole machine weighs only 1.25kg
- 6-inch ultra-high-resolution colour LED screen
- Can withstands a 1.2m drop test
- Liquid protection grade IPX1

### Convenient and accurate measurement

- Built-in RF communication, wireless data transmission
- Rapid blood pressure measurement technique
- Quick switch between patient types

### Specification

- Product Size: 130 x 125 x 219mm
- Net Weight: 1.25kg (battery excluded)
- Screen: 6 inch LED screen
- Battery Type: Rechargeable Lithium-ion battery
- Battery Capacity: 2200mAh
- Battery Recharging Time: Maximum 5.5 hours for charging when monitor is working
- Battery backup: 12 hours for standby mode
- Working Temp: 5-40°C



**AE1893** NC3 Monitor with SPO2, NIBP & Pulse Rate

**AE1893.1** NC3 Monitor with SPO2, NIBP, Pulse Rate & Temperature

**AE1893.2** NC3 Monitor Wall Mount Stand

**AE1893.3** NC3 Monitor Mobile Stand

## Lifeline Cart with Passive Lock System – Blue or Red

Lifeline helps improve Infection Control with a design that includes corrosion proof, easily cleaned polymer materials.

- Microban Antimicrobial Product Protection keeps the cart cleaner between cleanings.
- Lightweight polymer construction, 5' (127mm) diameter casters, an ergonomic handle and a proprietary 5th wheel steering system provides for easy manoeuvring

- Security seals secure the top compartment and drawers.
- Self-closing, full access drawers in a variety of heights, drawer divider systems, exchange trays and drawer labels are available to allow for easily accessed, organised contents.
- Drawers and many accessories may be added or reconfigured at the facility. Choose the drawers and accessories for today's needs and change them to meet tomorrow's needs.

### P2XP

**Drawers (Blue/Red Drawer pulls):**

1 x 75mm, 3 x 152mm

**Accessories:** Wastebasket, Defib Platform, Backboard, IV Pole, Security Seals



**AE1484** P2XP with Blue Drawers

**AE1629** P2XP with Red Drawers

### P3XP

**Drawers (Blue/Red Drawer pulls):**

2 x 75mm, 1x 152mm, 1 x 229mm

**Accessories:** 3 Locking Sides, Top Cavity Tray, Bins, Defib Platform, Suction Pump Shelf, Backboard, IV Pole, Gel Bin & Seals



**AE1485** P3XP with Blue Drawers

**AE1630** P3XP with Red Drawers

### P4XP

**Drawers (Blue/Red Drawer pulls):**

2 x 75mm, 1 x 152mm & 1 x 305mm

**Accessories:** 3 Locking Side Bins, Defib Platform, Backboard, IV Pole, Gel Bin and Security Seals



**AE1486** P4XP with Blue Drawers

**AE1631** P4XP with Red Drawers

### Available Accessories:

**AE1273** Suction Pump Shelf

**AE1274** Storage/Gel Bin

**AE1276** 75mm Drawer Divider Kit

**AE1277** 152mm Drawer Divider Kit

**AE1285** 2HK IV Pole with Cart Mount

**AE1487** Top Cavity Tray

**AE797** Plastic Security Seals (100)

## Emergency Resuscitation Trolley

Designed for ease of operation. All the trolleys contents are accessible without disturbing the work surface which is lipped to contain spill. Simple and effective locking system. Robust design but easily moved, manufactured from mild steel. Fitted with non-marking bumper and roller bearing castors.

### M-93 Basic 3 Drawer

- Storage space with flap closure
- 3 drawers: 3", 4 1/2", 7 1/2"
- 125mm Swivel Castors
- Oxygen bottle mount
- Push Handle
- Removable lipped worktop
- Security tag facility

### M-94 Basic 4 Drawer

- As M-93 but 4 Drawer: 1 1/2", 3", 7 1/2"

### M-93E / M94-E - 3/4 Drawer

- Anti-static Castors
- Side Shelf & Sharps disposal box
- Drawer tidy x2 - 13/18 spaces
- Pack of Seals & IV Pole

### M-93SE / M-94SE - 3/4 Drawer

As M-93E / M-94E but with:

- Defibrillator Mount
- 4-way electrical socket



<b>AE308</b>	M.93 Basic - 3 Drawer
<b>AE309</b>	M.93E Emergency - 3 Drawer
<b>AE310</b>	M.93SE Defib Emergency - 3 Drawer
<b>AE311</b>	M.94 Basic - 4 Drawer
<b>AE312</b>	M.94E with IV Pole - 4 Drawer
<b>AE313</b>	M.94SE with IV & Defib Mount - 4 Drawer

Code	Trolley Accessory	M-93	M-93E	M-93SE	M-94	M-94E	M94-SE
<b>AE687</b>	Anti-static Castors	Fixed	Standard	Standard	Fixed	Standard	Standard
<b>AE688</b>	Braked Castors	Fixed	Fixed	Fixed	Fixed	Fixed	Fixed
<b>AE689</b>	Drawer tidy	Optional	Standard	Standard	Optional	Standard	Standard
<b>AE690</b>	Drawer tidy	Optional	Standard	Standard	Optional	Standard	Standard
<b>AE691</b>	Cardiac Board	Fixed	Fixed	Standard	Fixed	Fixed	Standard
<b>AE692</b>	4-way electric socket	Fixed	Fixed	Standard	Fixed	Fixed	Standard
<b>AE694</b>	IV pole	Optional	Standard	Standard	Optional	Standard	Standard
<b>AE695</b>	Top guard rail	Fixed	Fixed	Fixed	Fixed	Fixed	Fixed
<b>AE696</b>	Folding side shelf	Fixed	Standard	Standard	Fixed	Standard	Standard
<b>AE697</b>	Waste bin	Fixed	N/A	N/A	Fixed	N/A	N/A
<b>AE698</b>	Sharps Bin	Fixed	Standard	Standard	Fit	Standard	Standard
<b>AE699</b>	Catheter holder	Fixed	Fixed	Fixed	Fixed	Fixed	Fixed
<b>AE700</b>	Seals 50pk	Standard	Standard	Standard	Standard	Standard	Standard
<b>AE701</b>	Stainless steel top	Fixed	Fixed	Fixed	Fixed	Fixed	Fixed

## Flexline™ Cart with Passive Lock System

Designed with interchangeable components and accessories for different configurations to conform to various applications.

- Flexline helps improve Infection Control with a cleaner design that includes corrosion proof polymer materials, smooth rounded corners to allow or easy cleaning
- \*Microban® Antimicrobial Product Protection that keeps the cart cleaner between cleaning.
- Lightweight polymer construction, integrated cart handles and 5" (127mm) polyurethane casters, 2 directional and 2 total lock, provide for smooth transport and nimble manoeuvring.
- Passive lock system utilises security seals to ensure security and controlled inventory management
- **Dimensions:** 568 x 733 x 883mm

### Available accessories:

<b>AE1489</b>	O <sub>2</sub> Oxygen Tank Holder - 100mm Diameter
<b>AE1490</b>	Peel Pouch Container
<b>AE1284</b>	Peel Pouch/Catheter Holder
<b>AE1280</b>	Clear Label Holder Pack - 10

Shown with 3 accessories



**AE1488** Flexline™ Cart - 2x75mm 1x152mm & 1x229mm

**AE1276** 75mm Drawer Divider Kit

**AE1277** 152mm Drawer Divider Kit

**AE1285** 2HK IV Pole with Cart Mount

**AE1272** Defib Platform Shelf

**AE797** Plastic Security Seals (100)

## Philips HeartStart HS1 Defibrillator

Designed for the ordinary person in the extraordinary moment. Philips HeartStart HS1 defibrillator acts as your personal coach to guide you through the process of treating a victim of suspected sudden cardiac arrest.

The HeartStart HS1 AED provides real-time guidance through simple, step-by-step voice commands and CPR coaching which can automatically adjust function for child/infant.

- Virtually ready to go the moment it arrives. With the Ready-Pack configuration, the HS1 AED is positioned inside the carry case, with Adult SMART Pads Cartridge and battery installed and with a spare Adult SMART pads cartridge in place.
- Includes features to help guide the treatment of sudden cardiac arrest with easy setup, clear voice commands and a real time metronome for performing CPR. HS1 conducts a series of automatic self-tests daily, weekly and monthly, including testing the pads, internal circuitry, waveform delivery and battery capacity so you can be assured when the moment comes, you will have a partner by your side.
- Equipped with integrated SMART Pads that will provide feedback to the AED so it can adapt its voice instructions to your actions and your pace. Prompts are repeated and rephrased if needed and include additional instructions to aid understanding.
- The system automatically senses Infant/Child SMART Pads are installed and adjusts both instructions and shock levels appropriately for infants and children.
- **Supplied with:** Battery & single set of SMART II pads
- **Dimensions:** 19c x 7 x 21 cm (H x D x W)
- **Weight:** 1.5 kg (With battery and pads)



**AE254** HS1 AED with battery and pads

**AE255.1** HS1 AED with standard carry case, battery and pads

**AE255** HS1 AED with slim carry case, battery and pads

**AE410.2** Battery Pack for HS1 / FRx

**AE255.6** HS1 SMART Pads - Adult

**AE255.7** HS1 SMART Pads - Infant/ Child

**AE255.2** HS1 Standard Carrying Case

**AE255.3** HS1 Slim Carrying Case

8 Year Warranty



**AE409** FRx AED with battery and pads

**AE410** FRx AED with carry case, battery and pads

**AE412** FRx AED with carry case, child key, battery and pads

**AE410.2** Battery Pack for HS1 / FRx

**AE410.1** FRx SMART Pads II (For both adults & children)

**AE410.4** FRx Standard Carrying Case

**AE410.3** FRx Infant/Child Key

**AE410.7** HS1/FRx Plastic Waterproof Shell Carrying Case

## Philips HeartStart FRx Defibrillator

Features intuitive, step-by-step voice instructions, including CPR guidance, and an audible metronome to help guide basic life support (BLS) responders while treating a suspected sudden cardiac arrest (SCA) Pre-connected SMART Pads II can be used for both adults and children.

Rugged, lightweight and reliable, it can withstand rough handling and extreme temperatures. When every minute counts, Philips HeartStart FRx is the partner by your side. Side by side. Step by step.

- Real-time, step-by-step voice commands paced to your actions, and an audible metronome and CPR guidance assist the responder. When treating an infant/child, simply insert the infant/child key and the FRx adjusts instructions and therapy.
- Patented Quick Shock feature allows the FRx to typically deliver a shock within 8 seconds after CPR.
- Lightweight, rugged and reliable, can withstand rough handling, extreme temperatures, and dusty or wet surfaces. Designed for use in harsh settings, it can withstand up to 500 kg (1,100 lbs) and drops from 1.2 m (4 ft).
- Pre-connected SMART Pads II can be used for both adults and children. It performs a series of auto self-tests, daily, weekly, and monthly to check pad readiness and system functionality. It can last up to four years between battery replacements.
- Arrives practically ready for rescue. Everything is connected and in place. Just pull the green tab to start the self-test.
- **Supplied with:** Battery & single set of SMART II pads
- **Dimensions:** 6 x 18 x 22 cm (H x D x W)
- **Weight:** 1.5 kg (With battery and pads)





AE1285



**AE252** 4000 Yellow with Stainless Steel Keypad Lock

**AE252.1** 4000 Green with Stainless Steel Keypad Lock

**AE252.2** 4000 Yellow with Plastic Level Handle

**AE252.3** 4000 Green with Plastic Level Handle

## Secure Outdoor AED Cabinet

Revolutionary outdoor polycarbonate defibrillator cabinet.

- IP66 standard, sealed against high pressure water and dust
- Suitable for use in coastal locations
- Fully corrosion resistant in UV protected high impact plastic
- Thermostatically controlled heater ensures the defibrillator is kept in optimum conditions
- Internal hook accommodates any defibrillator without case
- Large viewing window allows easy checking on AED status
- Double skin clamshell design provides additional insulation
- Includes comprehensive instructions and a fixing kit
- Cabinet dimensions: 465x435x240mm
- Manufactured in the UK
- **10 year manufacturers warranty (5 year on heater)**

## Philips HeartStart HS1 Trainer

Make learning easier and rewarding for every lay responder. Designed to prepare any responders to use the HS1 defibrillator.

- **Similar to the HS1 defibrillator to improve training**  
Train as if a life depends on it. Clear, calm voice instructions match those of the HeartStart HS1 defibrillator. The unit resembles the actual defibrillator, yet is sufficiently different to avoid inadvertent use in an emergency.
- **Instructional configuration options for realistic training**  
Works with internal and external pads adapters, allowing the instructor to provide clues towards pad placement for realistic training. Supports training for both adult and infant/child.
- **Realistic scenarios help you prepare for the real thing**  
Pre-configured sudden cardiac arrest scenarios simulate how the AED will operate during a real-life cardiac arrest event. Coaching for both adult and infant/child CPR is included
- **Reusable training pads for quick and easy learning**  
The training pads resemble defibrillation pads for a realistic training experience, yet are sufficiently different to avoid inadvertent use in an emergency. Easy switching between adult and infant/child pad cartridges, pads are reusable.



**AE257** HS1 AED Trainer with Remote Control

**AE257.1** HS1 Training Pads - Adult with Flat Man

**AE257.2** HS1 Training Pads - Infant/ Child with Flat Boy

**AE257.3** HS1 Training Pads - Adult (Pads only)

**AE257.4** HS1 Training Pads - Infant/Child (Pads only)



**PHILIPS**

**AE259** FRx AED Trainer

**AE259.1** FRx Training Pads with Flat Man

**AE259.2** FRx Training Pads II (Pads only)

**AE259.3** FRx Trainer Carry Case

## Philips HeartStart FRx Trainer

The FRx Trainer provides a variety of simulations, or training scripts, to help responders become familiar with the FRx defibrillator and allow them to practice basic skills to use the defibrillator in an emergency. The default trainer config can be adjusted to meet local protocol requirements.

- **Similar to the FRx defibrillator to improve training**  
Train as if a life depends on it. Clear, calm voice instructions match those of the HeartStart FRx defibrillator. The unit resembles the actual defibrillator, yet is sufficiently different to avoid inadvertent use in an emergency.
- **Instructional configuration options for realistic training**  
Works with internal and external pads adapters, allowing the instructor to provide clues towards pad placement for more realistic training. Supports training for both adult and infant/child patients.
- **Realistic scenarios help you prepare for the real thing**  
Preconfigured sudden cardiac arrest scenarios simulate how the FRx AED will operate during a real-life cardiac arrest event. Coaching for both adult and infant/child is included.
- **Reusable training pads for quick and easy learning**  
The training pads resemble defibrillation pads for a realistic training experience, yet are sufficiently different to avoid inadvertent use. Easy switching between adult and infant/child pad cartridges. The training pads are reusable.

# Rescue with Confidence



We hope that you never have to use it. But if you do, you can be confident you're prepared with ZOLL.

ZOLL AED technology removes the guesswork when assisting in sudden cardiac arrest emergencies. Unexpected heroes will be prepared to help save lives with ZOLL automated external defibrillators (AEDs).

**Real-time CPR feedback** guides rescuers in delivering optimal, lifesaving chest compressions.

**Designed for ease of use**, ZOLL AEDs provide step-by-step instructions throughout the rescue.

**Rescue Ready<sup>®</sup> Services** proactively help you track accessories and manage your AEDs to keep them ready for an emergency.

**Unrivalled AED innovations** have been empowering rescuers globally to help save lives for more than 25 years.

## Powerheart® AED G5 Automatic

The Powerheart G5 AED with Intellisense™ CPR provides corrective feedback to ensure delivery of high-quality compressions. One button dual language functionality and daily self-tests give rescuers the confidence to act.

**Intellisense™ CPR Feedback** – Distinct text/voice corrective CPR prompts for rate, depth and recoil.

**Rescue Ready®** – Conducts self-tests on pads, battery and internal circuitry.

**RescueCoach™** – Guides users through each critical step of the rescue with user paced voice/text prompts.

**Dual Language** – Change from primary to secondary language in the push of a button.

- STAR® biphasic truncated exponential
- **Therapy range (J):** 95J to 354J (adult)
- **Therapy range (VE):** 22J to 82J (paediatric)
- Factory default (nominal): Escalating Variable Energy (VE): 200VE, 300VE, 300VE
- Delivers a shock at the end of a CPR cycle in 10 secs or less
- Battery has a 4-year operational replacement guarantee\* minimum of 420 shocks (highest in the industry)
- Built-in automatic synchronisation feature with Pacemaker pulse detection and paediatric capabilities
- Metronome for CPR compression rate with Optional Intellisense CPR Feedback Device available
- Indicators for Rescue Ready®, battery, service & pad status

**Dimensions:** 9 x 23 x 30cm

**Weight:** 2.6 kg

\* **Some conditions do apply.** HCE provides this in line with manufacturer warranty. Contact us for more details.



8 Year Warranty



<b>AE1438</b>	Powerheart® AED G5 Automatic
<b>AE1439</b>	Powerheart® AED G5 Automatic with ICPR Device
<b>AE1442</b>	Adult Defib Pads for Powerheart® G5
<b>AE1443</b>	Adult Defib Pads for Powerheart® G5 with ICPR
<b>AE1444</b>	Paediatric Defib Pads for Powerheart® G5
<b>AE1445</b>	Battery for Powerheart® G5
<b>AE1446</b>	Premium Carry Case for Powerheart® G5

## Powerheart® AED G5 Trainer

This simple to use trainer has the look and feel of the Powerheart G5. It simulates AED functionality without delivering an electrical shock for a valuable hands-on rescue experience.

### Practice.

Students gain real world experience to help a sudden cardiac arrest victim. And with CPR feedback, they get a good feel for effective CPR.

### Ease of use.

Clear, instructive voice prompts guide students through a simulated rescue, and the built-in metronome sets the proper chest compression pace. Configurable for use in a variety of languages for added

### Flexibility.

Preparation. With four pre-programmed rescue scenarios, students will learn what to do in different situations.

- Includes four rescue scenarios
- Instructors can vary AED and rescue conditions to test student responses using the wireless remote
- Scenarios can be paused so instruction can be done throughout the training
- The trainer supports both automatic and semi-automatic AED operation
- Students can practice with reusable adult pads (with or without ICPR) and/or reusable pediatric pads

**Dimensions:** 8 x 32 x 24 cm



**AE1439.7**



**AE1439.6**



<b>AE1439.1</b>	Powerheart® AED G5 Trainer
<b>AE1439.2</b>	Powerheart® AED G5 Trainer with CPR
<b>AE1439.3</b>	G5 Adult Training Pads
<b>AE1439.4</b>	G5 Adult Training Pads with CPR Feedback
<b>AE1439.5</b>	G5 Paediatric Training Pads
<b>AE1439.6</b>	G5 Training Unit Remote Control
<b>AE1439.7</b>	G5 Training Language CD

## ZOLL AED Plus Defibrillator

The ZOLL AED Plus with clinically proven, integrated, real-time CPR feedback and industry leading long-life consumables, sets the benchmark for dependability, durability, performance and readiness. Bystanders will be able to act quickly and confidently in an SCA emergency.

**Real CPR Help® Technology** – Integrated, real-time feedback provides visual and audio prompts, keeping you on track to deliver high-quality CPR.

**One-Piece Pad Design** – Unique one-piece pad design ensures easy and accurate placement.

**Long Lasting Consumables** – Five (5) year battery and pad life mean fewer replacements, less maintenance, and AED readiness.

- Supports the UK Resuscitation Council's entire Chain of Survival, with easy-to-understand audio prompts & graphics
- The specially designed lid for the AED Plus can be placed under the shoulders to help maintain an open airway
- **Free product training DVD included**

**AE770** ZOLL AED Plus Unit



**AE772** CPR padz & First Responder Kit (5 year life) - Single

**AE772.1** Pedi padz II - Single (Paediatric)

**AE773** Wall storage Bracket

**AE775** Type 123 Lithium Batteries (10pk)

**AE776** AED Alarmed Wall Cabinet

## ZOLL AED 3 Defibrillator

The ZOLL AED 3 defibrillator leads the way with Real CPR Help® technology, which provides real-time feedback to guide rescuers in delivering high-quality CPR. The innovative, intuitive design and enhanced features of AED 3 will give unexpected heroes both the confidence and the knowledge needed to treat a SCA.

### Enhanced Real CPR Help

Proven Real CPR Help technology helps rescuers deliver high-quality CPR. The ZOLL AED 3 has a full-colour display with vivid rescue images, a CPR cycle timer, and a large colour bar gauge that shows CPR compression depth. In addition to displaying integrated, real-time CPR feedback, the ZOLL AED 3 screen also includes one-of-a-kind intuitive touch-screen capabilities. The touch-screen allows quick access to AED information and enables configuration without the need for additional external devices or software.

### Integrated Paediatric Rescue

The universal design of the CPR Uni-padz™ electrodes gives rescuers a single solution for both adult and paediatric victims of SCA. To treat a child, use the same set of pads and simply activate child mode.

### WiFi-connected

Cloud connectivity can enable automatic reporting of device status, giving you the confidence in knowing your AED is ready in an emergency. WiFi also provides the ability to quickly access and transmit cardiac arrest event data to medical professionals.

### Long-Life Consumables

Long-lasting batteries and pads increase readiness by reducing the frequency of maintenance.

**Wall cabinets available, contact us for details**

**AE1614** ZOLL AED 3 Semi-Automatic

**AE1615** ZOLL AED 3 Fully-Automatic

**AE1616** CPR Uni-padz Universal III (Adult/Paediatric)

**AE1617** Battery Pack for ZOLL AED 3 (Li-ion)

**AE1618** ZOLL AED 3 Carry Case

**AE1619** Spare Battery Case For ZOLL AED 3 Carry Case

**AE1620** Replacement shoulder Strap for ZOLL AED 3 Carry Case



**AE1618**



**AE1621** ZOLL AED 3 Wall Mount Bracket (Bracket Only)

**AE1622** ZOLL AED 3 Case Wall Mount Bracket (Bracket Only)

**AE1623** Standard Surface Wall Cabinet (Alarm Instr. & ILCOR labels)

**AE1626** Strobe for Standard Surface Wall Cabinet

**AE1627** AVIA 200 Outdoor Heated Unlocked Cabinet with alarm

**AE1628** Avia 210 Outdoor Heated & Locked Cabinet with alarm

## ZOLL AED 3 Trainer

### Training AED and Accessories

The ZOLL AED 3® Trainer is the only automated external defibrillator (AED) training solution that provides Real CPR Help®, real-time feedback on a trainee's compression quality. The trainer will allow students to learn proper rate and depth of CPR chest compression in a training setting.

The ZOLL AED 3 Trainer is designed to closely mimic the operation of the clinical AED, offering students a more realistic rescue experience. The ZOLL AED 3 Trainer includes:

- An active LCD display with full-colour rescue images that mirror what a student will see on a clinical ZOLL AED 3 device
- Contact sensors in the training pads that detect pad contact with the manikin, eliminating the need for a remote control to support rescue simulations
- An on-device pause button that allows the instructor to pause a training scenario
- Long-lasting consumables, which save time and money
- Easy USB software update/language configuration



7 Year Warranty



<b>AE1832</b>	ZOLL AED 3 Trainer
<b>AE1833</b>	Uni-padz Electrode Replacement Adhesive Gels - 5pk
<b>AE1834</b>	Uni-padz Electrode Replacement Liners
<b>AE1835</b>	Trainer demo manikin
<b>AE1836</b>	Trainer USB Software Upgrade Kit
<b>AE1837</b>	CPR Uni-padz electrode training harness

## ZOLL AED Pro Defibrillator

The AED Pro® Defibrillator informs users how well the compressions are being performed by using an exclusive one-piece electrode that can measure the rate and depth of each compression. Ensures the most effective CPR, the AED Pro® gives both audible and graphical feedback.

Designed for both basic and advanced life support. While it offers guidance to the BLS rescuer, it also provides more advanced capabilities for the professional rescuer.

- Audible Alarm to advise when to replace batteries
- Powered by 10 x 3v batteries
- Single piece electrode for accurate positioning
- The lid is designed to act as a passive airway support ensuring the airway position is maintained
- Includes: Carry case, batteries, adult electrode, face mask, gloves, razor, scissors, moist wipe & towel
- Manual Override with 3 lead cable & 1 x CPR Stat Pads



7 Year Warranty



<b>AE771</b>	Pro AED Semi-Automatic External Defibrillator
<b>AE772</b>	CPR padz & First Responder Kit (5 year life) - Single
<b>AE772.1</b>	Pedi padz II - Single (Paediatric)
<b>AE772.2</b>	CPR Stat padz (2 year life) - single

## ZOLL AED Plus Trainer II

The ZOLL AED Plus Trainer2 allows CPR and first aid instructors to have students experience what it's like to save a life with the AED Plus. Choose from four different fixed rescue scenarios or have complete manual control of the entire rescue. With the wireless remote you can control multiple AED Plus Trainer2s.

With a wireless remote in hand, the instructor can control the scenarios and teach students how to execute proper CPR/AED steps. There is a "Pause," which allows the instructor to speak between actions.

### The AED Plus Trainer2 Includes Everything an Instructor Needs:

- AED Plus Trainer2 training AED
- Wireless remote controller
- One set of AED Plus Training CPR-D-padz
- One set of AED Plus Trainer CPR-D-padz reusable gels
- Four D cell batteries
- Two AA cell batteries
- Operator's Guide



1 Year Warranty



<b>AE770.2</b>	AED Plus Trainer II - Semi Auto Lay Rescuer
----------------	---

## iPAD SP1 Automatic External Defibrillator

The iPAD SP1 AED has innovative features and uses advanced technology to save precious seconds when they are needed.

- Robust one-piece design with simple paediatric mode switch
- FREE Protective Carry Case Included
- Dual adult/child electrode pads & Ambient noise detector
- CPR detection, Metronome with visual & verbal guidance
- Battery level, Pad life & Operational status indicators
- Large internal memory can store 5 events, up to 3 hours each
- Simple data access with SD card download and free software
- Remote data conversion service
- Pads work for both Adults & Children (Child pads available)
- Ambient noise detector automatically adjusts voice prompt volume according to background noise
- Pre-connected 'Smart' electrodes
- Visual indicator gives 3 months notice before pads expire
- Warns the user if previously used electrodes are attached
- SD Card & IrDA make recorded data easily accessible
- **Dimensions:** 260 x 256 x 69.5mm
- **Weight:** 2.4kg

10 Year  
Warranty



**AE1560** Semi-Automatic iPAD SP1 with standard accessories

**AE1561** Fully-Automatic iPAD SP1 with standard accessories

**AE1568** Internal Cabinet Unlocked Alarmed

**AE1569** Wall mounting bracket for iPAD SP1

**AE1570** Standard AED Wall Sign

**AE1562** iPAD SP1 Training Unit with Remote Control

**AE1563** iPAD SP1 Disposable Battery Pack

**AE1564** iPAD Dual Use Adult/Child Electrode Pads (Pair)

**AE1566** Kit Inc. Gloves, Wipes, Face Shield, Tuff Cuts & Razor

**AE1567** 2GB SD Card for use in the iPAD SP1

## iPAD SP2 Automatic External Defibrillator

Designed for trained Medical Professionals who need greater functionality & clinical information. Retaining the user friendliness of its little brother, the SP2 is ideal for situations where advanced use is needed but space and time are limited.

- Pads compatible with Philips, Zoll and Physio Control (required adapter available on request)
- Dual Adult and child pads with simple button selection
- Bluetooth 3 lead ECG and Colour screen
- Manual override and energy select for trained users
- Bluetooth printer for on-scene printouts
- Multi event data recording and simple data download
- Ambient noise detector so audible in difficult environments
- **Dimensions:** 260 x 256 x 69.5mm
- **Weight:** 2.4kg

### iPAD SP2: Recharge Package with Manual Override

Package supplied with AED, Recharge Battery, Cardio Version capability, Recharge Docking Station, Carry Case, one set of Electrode Pads. (For full ECG acquisition - Bluetooth three lead)

### iPAD SP2: Recharge Package without Manual Override

Package supplied with AED, Rechargeable Battery, Recharge Docking Station, Carry Case, 1 set of Electrode Pads.

**AE1573** iPAD SP2 - Rechargeable Package without Manual Override

**AE1574** iPAD SP2 - Rechargeable Package with Manual Override

**AE1578** Bluetooth 3 Lead ECG Module for SP2

**AE1577** Rechargeable Battery for SP2

**AE1580** Battery Rechargeable Docking Station

5 Year  
Warranty



**AE1579** Bluetooth Printer Thermal 2/Charger for SP2

**AE1582** Printer Paper Thermal Roll for SP2 - 10pk

**AE1581** Disposable Electrode Pads for SP1/SP2

## Mindray D3 Platinum Defibrillators

Portable BeneHeart D3 is both an automatic and manual defib as well as a multi-parameter monitor and pacing device. Featuring biphasic technology with automatic impedance compensation, the D3 can escalate a shock up to 360J.

- Securely transmit to central stations and EPR systems
- Power on in 2 secs, charge in 3 secs, ECG recovery in 2.5 secs
- 4 in 1 design - manual mode (with sync cardioversion), AED mode, multi-parameter monitoring and pacing mode
- Up to 360J BTE (Biphasic Truncated Exponential) technology with impedance compensation
- 200 shocks (360J) or 4.5 hrs of continuous pacing (per battery)
- Automatic daily self-test ensures device is ready for use
- Monitoring options include 3/5-lead ECG, impedance respiration, SpO<sub>2</sub>\*, NIBP and etCO<sub>2</sub> monitoring
- Extensive storage allows trending of up to 24 hours ECG, 1000 events, 72 hours of parameters and 60 mins voice recording
- 7" full colour display (D3) and Integrated recorder (printer)
- Li-ion rechargeable battery with charge indicator
- Wi-Fi connectivity included as standard
- **Please see our website for further information & accessories**



AE065

Mindray D3 Platinum Defibrillator

## Penlon Prima 320 Anaesthesia System

Clinician-focused choices and benefits, including colour touchscreen display, up to six ventilation modes and optional CO<sub>2</sub> and SPO<sub>2</sub> monitoring.

The Prima 320 anaesthesia system has an integrated ventilator with up to six ventilation modes; CO<sub>2</sub> absorber with heater and large capacity absorbent canister; and a two station Selectatec™ compatible backbar.

- 8.4" TFT colour touchscreen (Optional 10.4" screen)
- Up to six ventilation modes
- Optional CO<sub>2</sub> and SpO<sub>2</sub> monitoring
- Selectatec® compatible backbar (two stations)
- LED illuminated work spaces
- Switchable front facing common gas outlet for open and closed circuit operation
- Low life costs and comprehensive warranties
- Integrated heated CO<sub>2</sub> absorber and bellows unit with ventilator interface
- GCX™ compatible aluminium uprights for additional accessory mounting
- Optional auxiliary O<sub>2</sub> outlet
- Up to three electrical outlets
- Anavue 4000 patient monitor

Penlon ♦



AE1856

Penlon Prima 320 Anaesthesia System

## Penlon Prima 450 Anaesthesia System

Clinician-focused choices and benefits, including electronic flow display options, and a functional top shelf module with power outlets and GCX compatible monitor mount.

A strong core specification including integrated AV-S Ventilator and A200SP Absorber. All models utilise a proven conventional control system with a mechanical anti-hypoxic system.

- Electronic flow display and conventional flowmeter options are available
- New top shelf with secure GCX™ mounting system suitable for patient monitors
- Anavue 4000 patient monitor
- Selectatec® compatible backbar (one or two stations)
- Intuitive design in a compact footprint
- Low life costs and comprehensive warranties
- GCX™ compatible aluminium uprights for additional accessory mounting
- Integrated heated CO<sub>2</sub> absorber and bellows unit with ventilator interface
- Large capacity drawer units
- HIS connectivity
- Six ventilation modes
- Illuminated work space

Penlon ♦



AE1857

Penlon Prima 450 Anaesthesia System

## Mindray EX-35 Anaesthesia Machine

Supports clinicians to make rapid adjustments to ventilation and monitored parameter settings, whilst the Smart Alarm system provides real-time information, quickly alerting users to any adverse situations and ensuring any required interventions can be delivered without delay.

- Automatic compliance and fresh gas compensation maintain accurate tidal volumes
- The integrated heated breathing system maintains a constant system (or core) temperature, virtually eliminating internal condensate build-up
- 10.4" full colour touchscreen with flat menu structure
- Manual/spontaneous breathing mode with respiratory monitoring capability
- Economical single container absorber reduces compressible dead space volume and is compatible with either non-proprietary prepackaged and loose fill solutions
- HL7 output allows interoperable connectivity with all leading clinical information systems
- Compatible with an extensive range of Mindray and third-party monitors and accessories

### Configurable ventilation modes:

- Synchronised Intermittent Mandatory Ventilation Volume Control and Volume Guarantee (SIMV-VC, SIMV-PC)
- Volume Controlled Ventilation (VCV)
- Pressure Control Ventilation (PCV)
- Pressure Support Ventilation (PS)



AE067 Mindray EX-35 Anaesthesia Machine

## Mindray SV600/SV800 Ventilators

Suitable for demanding hospital settings, these ventilators enable clinicians to set and deliver ventilation therapies quickly and easily through the intuitive touchscreen interface and intelligent decision-supporting tools.

**Adaptive Minute Ventilation (AMV):** uses Otis's Minimum Breathing Work Principle to intelligently select the optimal tidal volume and respiratory rate to switch seamlessly between the patient's mandatory and spontaneous breaths.

**IntelliCycle technology:** intelligently tracks waveforms to auto-adjust the patient's spontaneous breaths cycling point, reducing the risk of breathing asynchronously against the ventilator.

**CPRV:** the innovative CPR emergency ventilation mode that is instantly activated at the touch of a button. Auto-adjusting alarm limits and integrating CO2 monitoring, the CPRV mode ensures no time is lost in commencing emergency rescue.

- Two sizes: 15.6" (SV600) and 18.5" (SV800) TFT touchscreen
- Configurable interface further enhancing comfort and efficiency during patient care
- Extensive ventilation modes provide effective care for neonatal, paediatric and adult patients
- Supports high-flow oxygen therapy, non-invasive ventilation and invasive ventilation
- Plug and play modules, including SpO2, mainstream or sidestream etCO2
- Integrated neonatal module with tidal vol. as low as 2ml
- Detachable and autoclavable expiration/inspiration valves
- Dual channel auxiliary pressure measurements (SV800 only)
- Lung protection kit including Vt/IBW, C20/C, low flow PV tool and lung recruitment tool
- Backup air supply in case of air supply failure
- Seamlessly connect to many third party clinical information systems via Mindray's BeneLink module



AE068 Mindray SV600 Ventilator

AE069 Mindray SV800 Ventilator



## Brayden Baby Infant CPR Manikin

Developed with the help of European experts in the field of resuscitation, the unique features include lights providing real-time feedback for ventilation training and for chest compressions (depth, rate, recoil and finger/thumb position).

When all component parts of chest compressions are performed correctly, a CPR quality indication light illuminates on the forehead of the Brayden Baby manikin. Both sets of lights help guide the student to perform good quality infant CPR.

Brayden Baby is ideal for paediatric NLS, BLS, and EPALS.

- The non-toxic materials are soft and smooth to represent an infant's skin.
- Open and interconnected mouth and nose adds realism.
- Realistically large occiput so the Baby lies with its head in a realistic position (in flexion). The head needs to be moved to open the airway in to the neutral position.
- A realistic 'Jaw Thrust/Lift' manoeuvre is possible to practice opening the infant airway as required.
- Realistic occlusion of the airway for an infant when the head is hyper-extended.
- Brayden Baby allows the correct compression depth of at least a 1/3rd of the AP distance of manikin (4cm).
- Easy to change 'double filter' connected to the lung.

**AE1824** Brayden Baby Illuminating Infant CPR Manikin

### Correct Compression Rate and Depth

Chest compressions can be performed using two fingers (or two thumbs using the encircling technique) positioned just below the nipple light. Correct compression depth at least a third of the AP depth of the chest (4cm) at a rate of 100-120pm. The number of compressions to ventilations per cycle depend on local guidelines.



## Brayden CPR Manikins

### Brayden Advanced CPR Manikin

Brayden CPR Manikin is the first manikin that enables people to visualise the effects of CPR with lights to display blood flow.

- Chest compression indicating lights - Illuminates to represent the volume of blood being circulated. These will only be lit when the compression depth is over 5cm.
- Blood Circulation indicating lights - Illuminates to represent the flow of blood from the heart to the brain. The speed of the blood flow varies according to the depth and speed of your compressions.
- CPR Quality indicating lights - Illuminates to indicate blood is reaching the brain. Will only be lit when depth and speed of compressions are correct and chest has complete recoil.

Brayden Advanced Manikin Includes:

CPR Manikin, Spare Lung Bags, 6x Batteries, Spare Face Piece, Training Mat, Carry Case and 10x Face Shields

### Brayden Pro CPR Manikin

Designed for healthcare professionals and ideal for instructors. Brayden Pro App for download, both Android and now Apple iOS App available, allows instructors to connect six manikins to one Android tablet for more comprehensive training. Instructors can assess each student to see CPR technique, ventilation and if required, AED training.

- Fully compliant with AHA and ERC 2015 Guidelines
- Allows a full CPR scenario assessment to be carried out, including use of a defibrillator
- Six manikins can be connected to an android tablet or smart phone for multiple student training
- Multiple debriefing modes available, contact us for more information regarding systems

**Lung Kit Pack includes:**

Airway Filters, Flat Valves & Lung Bags (24 of each)

Brayden app  
available on  
Android & iOS



**AE1540** Brayden Advanced CPR Manikin - Red Illumination

**AE1650.1** Brayden Pro CPR Manikin - Red (Tablet not included)

### Manikin Accessories:

<b>AE1540.2</b>	Body Skin
<b>AE1540.3</b>	Head Unit
<b>AE1540.4</b>	Chin Piece
<b>AE1540.5</b>	BodyFrame
<b>AE1540.6</b>	Rib Frame
<b>AE1540.7</b>	Face Connection
<b>AE1540.8</b>	Airway Valve
<b>AE1540.9</b>	Lung Kit: Airway Filters (24), Flat Valves (24) & Lung Bags (24)
<b>AE1540.10</b>	CPR Clicker Unit
<b>AE1540.11</b>	CPR Clicker Actuator
<b>AE1540.1</b>	Face Skin
<b>AE1540.12</b>	Spring
<b>AE1540.13</b>	Carry Case
<b>AE1540.14</b>	Instruction Manual

## Hypo Box Hypoglycaemia Kit

HypoBox is a one-stop care kit that provides a range of glucose products for use in cases of low blood sugar. Conveniently contained in a bright and durable case for easy identification, each Hypo Box contains:

- 1 x GlucoTabs pack – 20 tablets (Individually wrapped)
  - 4g fast acting glucose per tablet
  - Recommendation is 3-5 tablets (12g – 20g glucose)
- 3 x GlucoJuice– 60ml bottles
  - Precise dose per bottle of 15g fast acting glucose per bottle
  - No need for part-measuring/decanting to container
  - Non-carbonated
- 2 x GlucoGel triple pack cartons
  - 3 tubes per carton
  - 10g glucose measure per 25g tube
  - Easy to administer
- Record Book for recording low blood sugar incidents



**BCH299** Hypo Box Hypoglycaemia Kit in Carry Case

## Gem II Powered Ring Cutter

The first battery powered ring cutter to be commercially available. Lightweight, single hand operated system that is quick, simple and safe to operate, capable of cutting through rings made of extremely hard metals.

Unlike a manual ring cutter this ring cutter's uniquely designed cutting disc guide component allows a ring or series of rings (up to 20mm wide and 6mm deep) to be cut through in one single uninterrupted operation.

- Efficient, simple one-handed and safe operation
- Cuts through materials that would take a manual ring cutter a long time or even prove impossible
- Flexible finger guard permits ease of insertion under rings
- Replacing cutting disc requires no expertise or special tools
- Powered by 4x AA size alkaline or re-chargeable batteries.
- Will cut any metal up to 20mm wide and 6mm deep (even those as hard as chrome plated steel)



**HSU538** Gem II Battery Powered Ring Cutter

**HSU539** Gem II Battery Powered Ring Cutter Rechargeable

**HSU539.4** Gem Ring Spreader

## Pocket Mask

The Laerdal Pocket Mask's design, filter and one-way valve make it a quality choice that provides protection during CPR.

By creating a slight distance between the patient and care provider the Pocket Mask also makes seeing patient lip color and chest movement easier.

- Superior protection with a disposable one-way valve and filter
- Pre-inflated cuff for a good, effective seal
- Oxygen inlet version allows delivery of supplemental oxygen
- Latex free & suitable for adults, children and infants
- Available in a special pediatric version that has a smaller, circular silicone mask that fits pediatric faces and provides a tighter seal for correct resuscitation.



**AE113** Laerdal Pocket Mask with Gloves & Case

**AE113.1** Valves for Laerdal Pocket Mask

**AE113.2** Disposable Filter

**AE114** Laerdal Pocket Mask with Oxygen Inlet

**AE114.1** Paediatric Pocket Mask with gloves & wipes in Soft Pack

## Ambu SPUR II Single Use Resuscitator

Ambu SPUR II provides users with exceptional tactile and visual feedback during resuscitation. The bag is highly responsive, featuring minimal mechanical resistance.

- SafeGrip™ surface for secure handling in any environment
- Ergonomic, lightweight design reduces fatiguing from use
- Fast recoil time allows for rapid ventilation
- Easy attachment of manometer and PEEP valve
- Unique single-shutter valve system for reliable functionality
- Swivel between valve and mask permits 360° positioning
- Integrated handle for user comfort and uniform compression
- Thin-walled compression bag for lung compliance and “feel”
- Extremely low valve resistance for unimpeded airflow
- Soft splashguard for user safety



**AE427** Adult Size – Single Patient Use Resuscitator

**AE427.1** Adult Paramedic Size – Single Patient Use Resuscitator

**AE428** Child Size – Single Patient Use Resuscitator

**AE429** Neonatal Size – Single Patient Use Resuscitator

## Standard Regulator & Flowmeter Pin Index

- Pin Nose Cylinder Fitting
- Brass Chrome Plated Body
- Pre-Set 4Bar
- HP Gauge
- Flowmeter:  
Various Flow Rate



**AE737** Oxygen 0-15Lpm

**AE738** Oxygen 0-4Lpm

**AE739** Med Air 0-15Lpm

**AE740** CO2 0-3Lpm

**AE741** CO2 0-12Lpm

## Standard Regulator & Flowmeter Bullnose

- Bull Nose Cylinder Fitting
- Brass Chrome Plated Body
- Pre-Set 4Bar
- HP Gauge
- Flowmeter:  
Various Flow Rate



**AE730** Oxygen 0-15Lpm

**AE731** Oxygen 0-4Lpm

**AE732** Med Air 0-4Lpm

**AE733** Med Air 0-15Lpm

**AE734** O2 & Humidifier 0-15Lpm

**AE735** CO2 0-3Lpm

**AE736** CO2 0-12Lpm

## The Bag II Disposable Resuscitator

Adult for patients 20kgs+, Child for patients 10-20kgs and infant for patients between 2-12 kgs. Child and infant sizes are fitted with a "pop off" valve on the elbow to ensure correct pressure of air is administered to smaller, more vulnerable lungs.

- Latex free - safe for latex-sensitive patients and staff
- Reinforced Non-Kink O2 Tubing prevents flow obstruction
- Universal Star-Lumen Tubing fits directly on flowmeter
- Adjustable Hook and Loop Handle reduces hand fatigue
- Material: PVC, PC, SI, Polypropylene
- 35 cm Pop Off Available for Child & Infant models
- Does not contain latex
- Patient Valve Dead Space: 6.8 ml
- Inspiratory Resistance: 1.5 cmH2O @ 50 LPM
- Expiratory Resistance: 1.8 cmH2O @ 50 LPM
- Storage Environmental Temperature Limits: -40°C to +60°C
- Operating Environmental Temperature Limits: -18°C to +50°C

**CE marked** - this product is in compliance with the essential requirements of Council Directive 93/42/EEC as amended by Council Directive 2007/47/EC.



**AE430.5** Infant Disposable Resuscitator with Mask - Size #1

**AE430.1** Child Disposable Resuscitator with Mask - Size #3

**AE430.2** Adult Disposable Resuscitator with Mask - Size #4

**AE430.4** Adult Disposable Resuscitator with Mask - Size #5

## Complete Entonox Pain Relief System

- Demand head complete with BS Hose & Probe
- Regulator and self sealing valve pin-index & carry case (blue)
- 1 x PI key and cord
- 1 x Adult face mask
- 1 x Child face mask
- 1 x Bacterial filter disk
- 1 x Packet of 5 mouthpieces



**AE862** Complete Entonox Pain Relief System

## Basic Entonox Pain Relief System

- Demand head complete with BS Hose & Probe
- Regulator and self sealing valve pin-index
- 1 x PI key and cord
- 1 x Adult face mask
- 1 x Bacterial filter disk
- 1 x Packet of 5 mouthpieces



**AE863** Basic Entonox Pain Relief System

## Philips EverFlo Oxygen Concentrator

Philips Respironics' compact, EverFlo Q is the first ultra-quiet concentrator available at an affordable price.

- Compact, modern design - EverFlo's ergonomic design takes up less space and doesn't draw as much attention.
- Ultra quiet operation reduces noise complaints - The EverFlo Q has only a 40 decibel sound level, which significantly increases patient satisfaction. A feature advantage that's attractive to both physicians and patients.
- Low maintenance for reduced costs - No homecare provider filter change for two years. Patients never change filters.
- Humidifier Bottle Platform - Designed to be compatible with all bottle styles and features an easy-to-use closure.
- The Right Fit series focuses on patients' needs - EverFlo is part of the Right Fit, a complete portfolio of oxygen products and programs inspired by patients and built for business.
- Lightweight for easy transport - The EverFlo Q weighs in at only 31 pounds, reducing shipping and storage costs and risk of injury.
- Lower power consumption makes EverFlo patient-friendly - The system uses less electricity and produces less heat.
- Recessed flow meter reduces accidental breakage
- Durable metal cannula is less likely to break

- **Sound Level:** 40 (typical) dB
- **Weight:** 14 kg
- **Dimensions (H x W x D):** 58.4 x 38.1 x 24.1 cm

**PHILIPS**  
RESPIRONICS



**HRS876** Philips EverFlo Oxygen Concentrator

**PHILIPS**  
RESPIRONICS

- **Size:** 29.2 x 25.4 x 15.2 cm (11.5" x 10" x 6")
- **Weight with battery:** 4.5 kb (10 lbs)
- **SimplyGo's battery duration:** 3.0 (pulse dose setting of 2\*) and 0.9 (continuous flow 2 LPM) hr
- **Sound level:** ≤ 43 dB at pulse setting 2 dB
- **Other accessories are available - Contact us for details**



**HRS875** Philips Simply Go Portable Concentrator with Mobile Cart

**HRS875.1** SimplyGo Lithium Ion Battery

**HRS875.7** SimplyGo Accessory case

**HRS875.6** SimplyGo External Battery charger UK (3 pin)

**HRS875.11** SimplyGo External Battery Module

## Philips Simply Go Portable Oxygen Concentrator

SimplyGo offers continuous flow and pulse-dose delivery in a device weighing 10 pounds. Reliably manage the therapy and lifestyle needs of your patients with just one POC.

### A new breed of POC for continuous and pulsed oxygen delivery

SimplyGo is the only POC to offer both continuous flow and pulse-dose delivery in a single device weighing only 10 pounds.

### Intuitive control panel is easy to read

SimplyGo's streamlined control panel is convenient and easy to use. All device operations are immediately at your fingertips.

### High impact resistant design sets new standards of ruggedness

With a long-life compressor, high-quality parts, a high impact resistant design, and oversized cart wheels, SimplyGo was built to set new standards of ruggedness. During development, SimplyGo was rigorously tested and subjected to extreme conditions including impacts, vibrations, and temperatures to deliver reliable performance day in and day out.

### Exchangeable batteries are powered for success

The battery is immediately accessible. One of the keys to SimplyGo's portability is its lightweight and compact battery. It is easily accessible and can be quickly changed by patients.

### Carrying case for convenience on the go

SimplyGo's attractive multi-purpose carrying case allows users to wear it over the shoulder or secure it to the mobile cart. An extra battery, cannula, or other accessories fit in the zippered pouch.

### Large oxygen output for all patient needs

SimplyGo has more than twice the oxygen output of any POC weighing 10 pounds or less. SimplyGo is able to keep up with your patients' portable oxygen needs today and tomorrow.

**Basic system includes:** SimplyGo portable oxygen concentrator, carrying case, mobile cart, one rechargeable Lithium Ion battery, DC and AC power cords, accessory case, and user manual.

# Philips SimplyGo Mini Portable Oxygen Concentrator

Designed to help you grow your business with the ability to offer lightweight, attractive features and true reliability.

### Built for the demands of today's active patients

At Philips Respironics, we have earned our reputation for designing and building excellence into all of our products. Now, with SimplyGo Mini, you can offer your patients the choice for excellence in lightweight portable oxygen concentrators.

### Durability matters to your business

Placing a POC with a patient, you need to know that it's going to have the reliability to help your business eliminate recurring oxygen delivery costs and cylinder hassles; reduce maintenance costs; ease inventory management; and minimize patient calls.

### Simply smart design

As the smallest and lightest POC ever developed by Philips, SimplyGo Mini is built for today's patients with features like: attractive and sleek design; easy-to-remove external battery; light weight intuitive, easy-read screen

### The Right Fit

SimplyGo Mini is part of the Right Fit, a portfolio of oxygen products and programs inspired by patients and for business.

- HRS877** SimplyGo Mini Oxygen Concentrator - Standard battery
- HRS878** SimplyGo Mini Oxygen Concentrator - Extended battery



- **Charge Time:** 8 Hours
- **Typical battery duration (On setting 2):** Up to 9 Hours
- **Size:** 10.2 x 8.3 x 3.7"
- **Weight:** 2.7kg
- **Outlet pressure:** 20 psig



**HRS877**



**HRS878**

- HRS878.3** SimplyGo Mini External Battery Charger (UK)
- HRS878.4** SimplyGo Mini Standard Lithium Ion battery
- HRS878.5** SimplyGo Mini Extended Lithium Ion battery
- HRS878.11** SimplyGo Mini Carry Bag and Strap (Black)
- HRS878.15** SimplyGo Mini Backpack (Black)

Accident & Emergency

## 525 5L Oxygen Concentrator

The latest Compact 525 oxygen concentrator is designed and built to meet the high demands of patients and cost challenges faced by service providers.

Delivering up to 5L per minute with high oxygen concentration across all flow rates and adopting the latest developments in the reduction of sound and power consumption, the latest 525 increases patient comfort and lowers operating costs.

- Improved sound level reduction - our quietest concentrator
- Front label with easy to read pictograms
- Service and maintenance friendly with simple 2 part design
- OSD® Sensor for continuously monitoring oxygen levels
- Visual and audible alarms for low oxygen levels, power failure, pressure drop and service required
- Oxygen outlet incorporating a fire protection adapter
- Turn-Down Technology lowers power consumption below flow rates of 2.5 L/min



- HRS160** 5 Litre Oxygen Concentrator
- HRS161** Tubing (50ft) for Oxygen Concentrator
- HRS162** Tubing (25ft) for Oxygen Concentrator

## 1025 10L Oxygen Concentrator

Built upon the reliable features of the 525 concentrator, the 1025 Oxygen Concentrator is designed to provide optimal oxygen delivery for patients with varying flow requirements.

Assembled in the US and built in the same shell as the 5L, this 10L unit is also compatible with cylinder transfill systems. With a weight of 42 lbs. and an identical footprint to the 525 unit, it is substantially smaller and lighter than other 10L concentrators.

- Lightweight and compact, only 42 lbs
- Maintains oxygen purity up to 5,000 ft
- Three-year provider service interval
- Exclusive DeVilbiss OSD® (Oxygen Sensing Device), standard on every unit, ensures patient safety and product reliability
- Equipped with accessible patient controls, bright LEDs, protected cannula fitting and recessed humidifier nook
- Convenient top and side handles for easy transport
- Accommodates up to 50ft of oxygen tubing & 7 ft of cannula

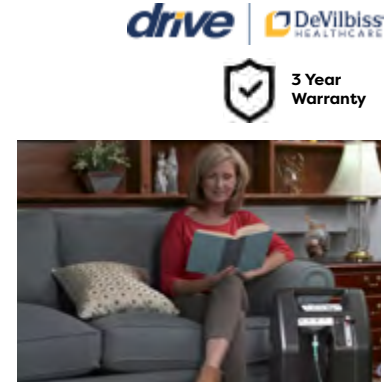

- HRS163** 1025 10L Oxygen Concentrator
- HRS161** Tubing (50ft) for Oxygen Concentrator
- HRS162** Tubing (25ft) for Oxygen Concentrator

## iGo Portable Oxygen Concentrator

The iGo Portable Oxygen System is the perfect solution for keeping an active lifestyle. This lightweight, 3-liter, portable oxygen system provides two modes of operation - continuous flow or PulseDose® delivery.

The reliability and safety of PulseDose oxygen delivery has been proven effective in clinical testing as well as through independent tests performed by physicians and respiratory therapists.

- Uses PulseDose® technology & can be used from 12v car plug
- Comes complete with a wheeled trolley, rechargeable lithium ion battery, AC and DC adapter and mains lead
- Variable flow rate up to 6 l/min at 91% ± 3%
- OSD Sensor for continuously monitoring oxygen levels.
- Alarms for low Oxygen levels, power failure or service required
- Can be operated from standard 12 V car charging socket
- FAA Approval for use on-board a plane
- Other than the gross particle filter, maintenance is reduced as the iGo requires no servicing for the first 3yrs

**Dimensions (W x D x H):** 28 x 20 x 38cm

**Total Weight (with battery):** 8.6 kg

**AE917** iGo Humidifier Kit incl. Hum, Stand and Elbow Adaptor

**AE918** iGo Oxygen Tubing Connector

**AE919** iGo Rechargeable Battery

**AE920** iGo Trolley

**drive** | **DeVilbiss**  
HEALTHCARE



**AE916** iGo Portable Oxygen Concentrator

**AE921** iGo Cabinet and Air Filter - 6pk

**AE922** iGo Intake Filter

**AE923** iGo DC Adaptor

**AE924** iGo AC Adaptor

## iGo2 Portable Oxygen Concentrator

The groundbreaking iGo2 Portable Oxygen Concentrator (POC) has created a new class of product - the auto-adjusting POC. This first-of-its-kind POC uses patented SmartDose Technology.

Now you can enjoy life more freely without worrying about changing oxygen settings during activity. This gives you the peace of mind and the freedom you have been looking for.

SmartDose Technology automatically adjusts oxygen dose to your breath rate, delivering more oxygen when needed to help keep you saturated. It is not necessary for you to manually adjust settings as oxygen levels will remain consistent during activity.

- Lightweight and easy to carry in its practical shoulder bag
- Thanks to its high-quality design the iGo2 is very durable
- Federal Aviation Administration (FAA) compliant in-flight use
- Equipped with a protective, rugged overmold, it provides an extra layer of protection against everyday demands of life
- **Max Output:** 1014 ml
- **Oxygen Output:** 94%
- **Weight:** 2.2kg
- **Battery life:** 3.5hrs

**Supplied complete with:** Battery, case, power supply, cord and car adapter

**AE1838** iGo2 Portable Oxygen Concentrator EU+UK

**AE1839** iGo2 Battery Pack

**AE1840** iGo2 Carrying Case

**AE1841** iGo2 Sieve Bed Replacement Kit

**AE1842** iGo2 Battery Charger (UK)

**drive** | **DeVilbiss**  
HEALTHCARE



## Invacare Platinum Oxygen Concentrator

The Platinum Mobile is the latest truly portable and elegant oxygen concentrator from the worldwide leader in oxygen therapy for more than 30 years.

Delivers the latest in pulsed flow technology to cover clinical patient needs with 4 individual pulse setting positions. Stylishly designed and featuring an intuitive interface, the Platinum Mobile brings simplicity and innovation together in a compact, lightweight, quiet and robust package.

Durability and reliability are critical elements to patients, clinicians and providers, which is why Invacare has performed the latest tests conformed to the most stringent standards. Features include Water Resistance, Impact Protection and

The Platinum Mobile concentrator was built to be the best oxygen partner for more active Chronic respiratory insufficiency patients, but also to help minimise the risk factors associated with interstitial lung diseases including prior or concomitant oxygen therapy. The Platinum Mobile has a range of features and accessories designed to give a 'breath of new life' to users.

**AE1854** Invacare Platinum Portable Oxygen Concentrator

- **Highly Portable:** lightweight design and an easy-to-clean carry bag. Use with single or dual strap.
- **Lightweight:** At only 2.22kg, the unit promotes ambulation. Designed to encourage mobility, travel and independence.
- **Sound Level:** A sound level of <40dBs for use in quiet areas
- **Enhanced Battery Life:** Operates for up to 5hrs on a single battery and up to 10hrs with the addition of a second battery.
- **Bright LCD Screen:** Backlit, LCD screen at top of unit



## Ease II Kits

**Free life time servicing (No servicing required for first 5yr)**

- On demand Nitrous Oxide/Oxygen (Entonox™) system for delivering up to 300 litres/min. Oxygen only version available.
- Portable first stage regulator and cylinder version
- Low pressure pipeline version for obstetrics and general nursing applications
- Test/Purge facility on the demand valve, easy to clean and reassemble
- Hose with BS probe for connection into CD system / wall outlet
- Conforms to BS 4272: Part 2
- Low inspiratory effort demand valve



**AE1542** Ease II Kit With Regulator And Bs Probe

**AE1543** Ease II Kit With Bs Probe

## Mars 2

Demand valve and trigger (100 l/min flow), control module (3 settings: Adult/Medium/Child). Pin index regulator with 11 setting constant flow (1 - 23 l/min). Carry bag, masks and harness.

- The operator does not have to make judgements on lung capacity to select a volume; only basic size/type of patient
- The MARS will control both tidal volume and pulse frequency within the parameters laid down in the British Standards
- 'Fail safes' and will vent excess gas whilst giving the operator an audible warning about incorrect use



**AE1544** Mars 2 with regulator - Standard

**AE1545** Mars 2 with regulator - Industrial

## ACCOSON™ Tourniquets

**The ACCOSON™ range of tourniquets**

Available with velcro or clasp fastening. Pull tight elasticated version available in 3 colour options.



**AE020.1** ACCOSON™ Pull Tight Elasticated - Red

**AE020.2** ACCOSON™ Pull Tight Elasticated - Blue

**AE020.3** ACCOSON™ Pull Tight Elasticated - Green

## ACCOSON™ Infusion Cuff

**The ACCOSON™ latex free cuff made to aid rapid IV infusion**

- Inflatable device to aid rapid IV infusion
- Large scale accurate pressure gauge attached
- Gauge protector
- Strong fine mesh front
- Infusion cuff includes inflation bulb with a release valve
- Completely latex free
- Components also available as spare parts



Made in the UK

**AE314.1** ACCOSON™ 500ml Infusion Cuff

**AE315.1** ACCOSON™ 1000ml Infusion Cuff

## Saver Safe Evacuation Chair

A single user operation emergency evacuation chair. It glides down stairs smoothly to ensure no heavy lifting is required.

- Two person lift usage
- Lower, adjustable grip handle for operator control & comfort
- Lightweight, with compact profile for easy storage
- Seat attached all round, allowing easy lateral patient moves
- Removable, adjustable head pad and comprehensive patient restraint systems to enhance patient comfort and safety
- Supplied with wall bracket, cover and signage
- Dimensions: 1100 x 430 x 690mm (open)
- Weight 16.4 Kg / Max. Load Capacity 180Kg

**AE1401** Saver Safe Evacuation Chair



1 Year  
Warranty



Free Demo

## PATSLIDE® Patient Transfer

- Proven itself through daily use in hospitals around the world.
- PATSLIDE® not only makes the job easier and safer, but also reduces the risk of injury to nursing staff.
- The distress and discomfort that patients can experience when being transferred is eliminated.
- This unique product has reduced back strain occurring during patient transfer – a factor which previously contributed to many lost working hours and long-term staff disability.
- Safe & Easy to use, Static Insulative and Radio-Lucent
- Lightweight, Resilient and Tolerant to impacts

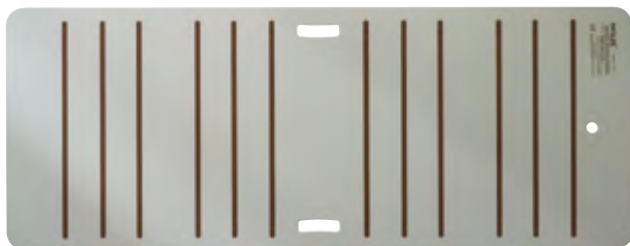

**AE1202** All Purpose - 1525 x 635mm

**AE1203** Theatre - 1525 x 560mm

**AE1204** Slimline - 1400 x 480mm

**AE1205** Half Size - 750 x 635mm

## FERNO SCOOP® 65 EXL Stretcher

Fast becoming the Paramedics stretcher of choice the SCOOP® 65 EXL provides superior comfort and spinal immobilisation

- Twin safety locks – allow fast uncoupling of one or both ends
- Integrated Pins – Can be supplied with or without pins for use with quick release retaining straps
- Safe and secure – with four biosafe speedclip straps to keep casualties firmly but gently secured
- Thermally-treated Polymer – does not get too hot or cold, keeping the casualty more comfortable
- Ergonomic Handles – Supporting correct posture for lifting
- Adjustable Length – Telescopic tubes allow length adjustments to fit patients of various heights



**AE1811** Stretcher with pins, 4 Biosafe straps and speedclips

## Duo-Fold Stretcher

### Collapsible Patient Stretcher

- **Easy lifting**  
poles constructed from lightweight aluminium
- **Easy & Quick deployment**  
Collapsible spreader bars and low profile hinges
- Stirrup feet raise the casualty up off the ground
- Folds in length and width to a very compact size
- Orange vinyl fabric is impervious to stains and mildew for easy care and maintenance
- Non-slip plastic carrying handles
- Weight: 6kg
- Dimensions: 2060 x 540 x 150mm
- Dimensions (Folded): 1030 x 250 x 150mm
- Max. Load Capacity: 159 kg / 25 stone



**AE316** Duo-Fold Stretcher

**AE317** Carrying Case for Duo-Fold





**AE208** Lifting Scoop Stretcher

## Lifting Scoop Stretcher

- Three quick release patient restraints
- Extendable foot section
- Lightweight alloy materials
- Twin safety lock for smooth locking and unlocking
- Length (max) 2010 mm
- Length (min) 1660mm
- Width 430 mm
- Height 67 mm
- Weight 9.7 kg
- Load Limit 159 kg/25st/350lbs

## Frac-Immobiliser

- X-Ray permeable
- Surface facilitates easy cleaning
- Velcro strapping secures device around injured limb
- Patient comfort - vinyl coated padding

**AE057** 2 Strap Immobiliser

**AE058** 4 Strap Immobiliser

**AE059** 5 Strap Immobiliser



## Frac-Strap and Padding

- Complete with storage wallet
- Secure fit - velcro fastenings
- X-Ray permeable
- Padding for comfort and support
- Tough hygienic vinyl coated nylon
- Efficient method of strapping damaged limbs

**AE320** Frac-Strap and Padding



## BaXstrap Spineboard

As a rescuer you want your spineboard to be comfortable for our patient, as well as being rigid and lightweight to help yourself. Furthermore, you also want to be able to store the board as easily as possible.

The BaXstrap Spineboard provides this and is one of the lightest boards on the market. The contoured design allows the board to nest compactly. This unique feature also offers patients more comfort, making it less likely that they would move around and aggravate their injuries. The product is also completely latex free.

- Five Year Limited Warranty
- No seams make it easy to clean and decontaminate
- Extra large handholds make it easier to pick up
- Withholds greater than 110kg
- Includes strap holes for paediatric patients, eliminating the need to use towels to fill the extra space between patient and strap
- BaXstrap can be used in water, in the mountains, at home or on the road
- Durable moulded-in customised labelling available
- Radiolucent MRI and CT scan compatible

**AE278.3** Board & Premium Strap w/sewn loop ends

**AE278.4** Board & Premium Strap w/speed clip ends

**AE278.5** Speedblocks Strap and Pad Replacement Set

**AE278.1** Speedblocks Starter Pack

**AE278.2** Speedblocks Set

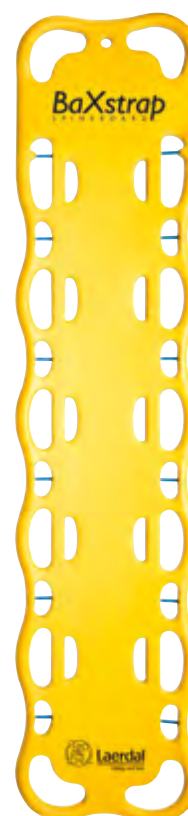

## ASPEED Professional Aspirator

A piston-type electric aspirator. This pump features a protective thermal cutout relay as well as a protective cap which prevents fluids from reaching the pump and damaging the unit.

- Autoclavable 1L Jar with safety valve (overflow protection)
- Disposable Suction Liner 1000cc
- 99% Antibacterial Hydrophobic Filter & 1 Spare
- Sterile, Disposable Cannula & Manual Flow Regulator
- Set of Atoxic, Sterilisable Silicone Tubes
- Disposable suction liners available to purchase
- Protective cap prevents liquids & secretions damaging pump
- Made in Italy
- **Operating Cycle:** Continuous
- **Adjustable vacuum level:** 0 ÷ - 0.85 bar
- **Air flow:** 22ltr/min (double pump)
- **Dimensions** 18.5 x 33 x 21 cm
- **Weight:** 4.2 kg



3A HEALTH CARE is an OMRON Healthcare Europe company



3 Year Warranty



**AE603** ASPEED Pro Aspirator Double Pump (1L Cannister)

## ASPEED 2 Professional Aspirator

Medical/surgical aspirator intended for home treatment/patient use. Select your preferred choice of single or double pump model.

### Single Pump:

- Air Flow: 15ltr/min
- Adjustable Vacuum Level: 0.85 bar (0 ÷ - 85 kPa) reg.
- Noise Level (at 1m): 63 dBA
- Weight: 2.5 kg
- Autoclavable 1L Jar with safety valve (overflow protection)
- Disposable Suction Liner 1000cc
- 99% Antibacterial Hydrophobic Filter & 1 Spare
- Sterile, Disposable Cannula & Manual Flow Regulator
- Set of Atoxic, Sterilisable Silicone Tubes
- Made in Italy
- **Dimensions:** 196 x 357 x 185 mm
- **Operating Cycle:** Continuous
- **Low Flow:** High Vacuum

### Double Pump:

- Air Flow: 22ltr/min
- Adjustable Vacuum Level: 0.85 bar (0 ÷ - 85 kPa) reg.
- Noise Level (at 1m): 65 dBA
- Weight: 3.2 kg



3A HEALTH CARE is an OMRON Healthcare Europe company



3 Year Warranty



**AE1843** ASPEED 2 Pro Aspirator Single Pump (1L Cannister)

**AE1844** ASPEED 2 Pro Aspirator Double Pump (1L Cannister)

## Minispeed Battery Plus Aspirator

Medical/surgical aspirator with rechargeable battery intended for field use. Can be used at home, in clinic or in nursing home.

- Made in Italy
- Autoclavable 1L Jar with safety valve (overflow protection)
- Disposable Suction Liner 1000cc
- 99% Antibacterial Hydrophobic Filter & 1 Spare
- Sterile, Disposable Cannula & Manual Flow Regulator
- Set of Atoxic, Sterilisable Silicone Tubes
- Power Cord, Carry case & Multivoltage charger unit Included
- Rechargeable Battery 12v 32Ah

### Technical Information:

- Low Flow: High Vacuum
- Continuous Use: 35 min. of endurance
- Air Flow: 18ltr/min
- Adjustable Vacuum Level: 0 ÷ - 0.80 bar
- Noise Level (at 1m): 56 dBA
- **Dimensions:** 370 x 100 x 240 mm
- **Weight:** 5.5 kg



3A HEALTH CARE is an OMRON Healthcare Europe company



3 Year Warranty



**AE1845** Minispeed Battery Plus Aspirator (1L Cannister)

## ASPEED 3.0 Aspirator

Medical/surgical aspirator intended for home treatment and/or outpatient use.

- Made in Italy
- Autoclavable 1L Jar with safety valve (overflow protection)
- Disposable Suction Liner 1000cc
- 99% Antibacterial Hydrophobic Filter & 1 Spare
- Sterile, Disposable Cannula & Manual Flow Regulator
- Set of Atoxic, Sterilisable Silicone Tubes

### Technical Information:

- Low Flow: High Vacuum
- Air Flow: 16ltr/min
- Adjustable Vacuum Level: 0 ÷ - 0.65 bar
- Noise Level (at 1m): 65 dBA
- **Operating Cycle:** Continuous
- **Dimensions:** 170 x 300 x 260 mm
- **Weight:** 2.3 kg



3A HEALTH CARE is an OMRON Healthcare Europe company



3 Year Warranty



**AE1846** ASPEED 3.0 Aspirator

## Laerdal Suction Unit - LSU

The Laerdal Suction Unit (LSU) is a portable, powerful and highly reliable suction unit designed for optimal preparation in emergency situations.

The LSU is available as a reusable or semi-disposable option, depending on your requirements.

- Can reach a vacuum of 500+mmHg
- Self tests show if LSU is ready for use
- Built-in, quick charging battery charger
- Integrated vacuum regulator-on knob
- Large buttons for use even whilst wearing gloves
- High efficiency filter kit
- HEPA rated bacterial filter
- LED display for use day or night
- Children vacuum range area (marked blue) on control panel
- No-tools-necessary field changeable battery
- **5 year limited warranty**

The Laerdal Suction Unit comes complete with charging cords, your selection of canister with patient tubing, battery and directions for use

**AE401** Replacement Canister (for AE097.4)

**AE402** Disposable Tubing (for AE097.4)

**AE406** Wall Bracket (with AC option)

**AE406.1** Wall Bracket (without power cord)

**AE406.2** Wall Bracket (with DC option)

AE097.4



AE097

**AE097** LSU with Reusable Canister & Tubing

**AE097.4** LSU Serres Suction Bag Canister System

**AE400** Disposable Serres Liners - Single (for AE097.4)



AE1258



AE1259

**AE1258** LCSU4 - 800ml

**AE1259** LCSU4 - 300ml

**AE1259.1** 300ml Disposable Canister for LCSU4

**AE1259.2** 800ml Disposable Canister w/tubing

**AE1259.3** 800ml Disposable Canister w/tubing - 6PK

## Laerdal Compact Suction Unit 4 LCSU4

The Laerdal Compact Suction Unit (LCSU4) suction unit combines rugged design with lightweight portability, an essential tool for every first responder.

After Laerdal's 40 years of suction innovation, the LCSU4 is our most advanced compact unit. Weighing only 1.5kg and having a flow rate of 30 LPM, it is the perfect tool for first responders and medical personnel. The disposable canister removes the hassle of external tubing that could slow down the rescue process.

- The filter stops flow when the canister is full or the filter becomes saturated if the unit tips onto its side during use
- Once wet the filter forms a gel preventing fluids to the pump
- Click-in-place 300 ml canister, no vacuum tube needed
- 800 ml canister option when extra volume is needed
- Internal integrated filter systems for all canisters
- High efficiency filter kit (for 800 ml solution)
- HEPA rated bacterial filter and Big vacuum regulator dial
- Children vacuum range area (marked blue) on control panel
- Wire Stand for stability (for both versions)
- High density carry bags and Rechargeable Battery,
- **Air Flow @ Vacuum Inlet:** 30 LPM (free flow) typical
- **Vacuum Max:** 550+ mmHg (73.3 kPa)
- **Vacuum Range:** 50 - 550+ mmHg (6.7 - 73.3 kPa)

**AE1260** Replacement Filter 10pk

**AE1261** External Battery Charger LCSU4

**AE1262** Carry Bag - LCSU4 300 ml

**AE1263** Carry Bag - LCSU4 800 ml

## VacuAide 7305 Portable Suction Unit

A small and lightweight portable aspirator. Primarily used for bronchial / oral hygiene, effective airways clearance. Meets the stringent ISO 10079-1 standards for emergency transport suction. It can be used from its battery, direct power or 12V DC car port.

The 7305 VacuAide suction unit is available with either a disposable 800ml collection bottle or reusable 1200ml bottle for repeated use. Bottles also include an automatic float shut off.

- High performance capabilities with a vacuum range of 80-550 mmHg and a flow range of 0-27 l/min.
- Comes complete with a (60 min battery life) rechargeable battery, 12v DC in car charger, UK mains lead and carry case.
- Has a switch power supply with on AC voltage 100- 240V
- Has an integrated bacterial filter.

**AE096** Unit with 800ml Disposable Bottle

**AE096.13** Unit with 1200ml Re-Useable Bottle

**AE098.10** Collection Bottle 1200ml Re-usable



**drive**  
DeVilbiss  
HEALTHCARE



**AE098.8** 1200ml Re-Usable Bottle Kit

**AE096.6** Bacterial Filter - 12pk

**AE096.11** Elbow Connection

**AE096.18** 1200ml Bottle Bracket

**AE096.19** 5" Tubing Package - 6pk

## VacuAide 7314 Portable Suction Unit

Designed to perform effective airways suctioning in a comfortable, safe way. The 7314 is very quiet, when compared to other options. The low noise does not compromise performance.

The internal battery can give up to one hour life. The 7314 and its accessories sit neatly in the carry bag. Built to ISO 10079-1.

- Low noise with great performance
- Easy to operate & easy to clean
- Built to the ISO standards for emergency transport suction
- 50-550 mmHg pressure range 27 l/min air flow
- Complete with 100-240 V power supply and 12V car adaptor
- Available as a battery version for ambulatory use (7314P series) or as a 'mains-only' operated model (7314D series)

**AE098** Unit with 800ml Disposable Cannister

**AE098.12** Unit with 1200ml Re-Useable Cannister



**drive**  
DeVilbiss  
HEALTHCARE



**AE098.7** 1200ml Reusable Bottle Kit

**AE098.8** 1200ml Re-Usable Bottle Kit

**AE098.9** 1200ml Reusable Canister and Lid only

**AE096.6** Bacterial Filter - 12pk

**AE096.11** Elbow Connection

**AE098.6** Connection Tubing 4 3/8" - 12pk

The **Disposable Liner System from Flovac** can be used with all VacuAide models. The system provides collection of fluids suctioned in a hygienic way. It enables potentially infected materials to be collected, transported and disposed of safely.

**AE096.20** Flovac Liners 1L

**AE096.21** Flovac Gel Liners 1L

**AE096.22** Reusable Flovac Canister 1L

**AE096.23** Inline male to male connector - 5pk

**AE096.24** 26cm Connection Tubing - 5pk



## Accessories for VacuAide Canister Configurations:

The **800ml QSU disposable canister** is single patient use. It is more suited to use in a stationary environment. Works with both the VacuAide 7305 and 7314 series.

**AE098.1** 800ml Canister Kit Assembled Single Unit

**AE098.6** Connection Tubing 4 3/8" - 12pk

**AE098.4** DeVilbiss Replacement Filter Cartridge - 6pk

**AE098.5** DeVilbiss Replacement Filter Cartridge - 12pk

The **800ml CLASSIC disposable canister** is suitable for patients who have a high ambulatory requirements or for use whilst in transport. Single patient use & works with both the series.

**AE096.16** Collection Bottle 800ml

**AE096.6** Bacterial Filter - 12pk

**AE096.11** Elbow Connection

## Mini Rechargeable Aspirator 12v Mains SAM e.p.s Portable Suction Unit

A professional aspiration device specifically for post-tracheotomy patients who need numerous daily applications.

- **Voltage:** 12VDC / **Air flow:** 18 lt/min
- **Adjustable Vacuum level:** 0/-0,80 bar
- **Continuous use:** 35 minutes / **Noise level (at 1mt):** 55dB
- **Dimension:** 37 x 10 x 24 cm / **Weight:** 5.5kgs



**AE248** Mini Rechargeable Aspirator 12v with Carry Case

**AE096.1** Yankaer Suction Catheter - 10pk

- Supplied with 1 x 1L autoclavable collection jar
- Support for Liner Systems (Reusable, Serres, Abbot & VacSax)
- Lit digital vacuum display with Service indicator
- **Noise Level:** 46dB max, <30dB min
- **Flow rate up to:** 32 l/min
- **Maximum vacuum:** 600mmHg
- **Battery run time:** 125 minutes on full, over 11 hours on low



**AE1328** SAM e.p.s Emergency Portable Suction Unit

**AE1324.3** Disposable Hydrophobic Filters - 24pk

## SAM 12 Suction Unit

A high flow, high vacuum suction unit with single collection jar for ward use, general suction and out in the community

- **Simple, easy controls:**  
Gauge graduated in mmHg and kPa – adjustable knobs
- **Mains operated only**
- Supplied with 1 x 2L autoclavable collection jar
- Support for Liner Systems (Reusable, Serres, Abbot & VacSax)
- Hydrophobic filter to protect the pump from accidental overflow by preventing liquid from passing through
- **SAM 12 unit available in mobile version** with 2x antistatic castors and high level handle, also comes as a static version
- **High flow rate:** 30 l/min
- **High maximum vacuum:** 650mmHg

**AE1325** SAM 12 - Mobile Version

**AE1324** SAM 12 - Static Version

**AE1324.4** SAM 2, 2L Autoclavable Collection Jar



**AE1324.2** Disposable Bacterial Filters - 24pk

**AE1324.3** Disposable Hydrophobic Filters - 24pk



**AE1326** SAM 35 - 2 x 2 Litre Jars

**AE1327** SAM 35 - 2 x 4 Litre Jars

## SAM 35 Suction Unit

A top quality surgical suction unit providing high flow, high vacuum performance. Designed primarily for major operating theatre use and can also be used in lipo-suction procedures. Its reputation for reliability and ease of operation has established it among the most widely used units in the medical world.

- Simple controls - vacuum gauge graduated in mmHg and kPa
- High flow rate 50 l/min, high maximum vacuum 675mmHg
- Supplied with choice of 2x2L or 2x4L jars
- Antistatic castors and convenient push handle
- Hydrophobic filter to protect the pump from accidental overflow by preventing liquid from passing
- **Weight:** 25kg
- **Noise Level:** 55 dB

**AE1324.2** Disposable Bacterial Filters - 24pk

**AE1324.3** Disposable Hydrophobic Filters - 24pk

### Welch Allyn® Connex® Spot Monitor

Comprehensive monitoring—from basic vitals to early warning scores and interval monitoring in a simple, secure, connected solution.

Help enhance productivity and patient outcomes by capturing a full set of vital signs in less than a minute. With an easy-to-use, touchscreen display, this monitor provides the accurate vital signs measurements you need—including blood pressure averaging, custom scoring and spot check or interval monitoring.

Connects wirelessly to your EMR and sends vitals to the patient chart from the point of care to improve efficiency and accuracy.

Adapt to the needs of your facility with an upgradeable design and custom configurations. Help identify and respond to signs of patient deterioration sooner with Early Warning Scores.

- Two modes: spot check and interval monitoring
- SureBP technology can provide blood pressure in only 15 secs
- BP averaging to ensure accurate hypertension diagnosis
- Select thermometry from: SureTemp Plus Oral/Axillary or Braun ThermoScan PRO 6000 Tympanic Thermometry
- Nonin® SpO2 technology included
- Single sign-on options—including integration with Imprivata—available for quick, secure clinician login
- Options for mobile stands, wall mounts and integrated exam systems to solve workflow requirements
- Secure: FIPS-approved encryption of transmitted data
- Automated Early Warning Scoring help clinicians identify and respond to signs of patient deterioration (ie. MEWS, NEWS)
- Customizable workflow options for recording patient obs (ie. Is & Os, Pain Scale) and vitals modifiers (ie. BP cuff location)
- Ships as standard with one Adult and one Large Adult cuff



AE1518

Baxter



AE1520

**AE1518** CSM with BP, Pulse, SpO2 & Early Warning Scores

**AE1519** CSM with BP, Pulse, SpO2, SureTemp & Early Warning Scores

**AE1520** CSM with BP, Pulse, SpO2, Pro6000 & Early Warning Scores

**AE1520.1** CSM with NIBP, Pro6000 & Early Warning Scores

**AE1521** Welch Allyn Classic Roll Stand for Spot Monitors

**AE1762** Welch Allyn® Work Surface and Accessory Manag. Stand

**AE1763** Welch Allyn® Wall Mount with Basket

**AE1765** Welch Allyn® Accessory Power Manag. Stand

### Welch Allyn® Connex® Vital Signs Monitor

Connex Vital Signs Monitor (CVSM) is the next generation in patient monitoring with easy-to-use color touchscreen, advanced vital signs technology and with optional ECG and respiratory monitoring capabilities. Plus, Electronic Medical Record (EMR) integration gives clinicians immediate access to the information they need, when and where they need it—with no extra steps.

- SureBP® tech measures blood pressure as the cuff is inflating
- Supports adult, paediatric & neonatal
- Pulse rate and MAP included
- SureTemp Plus thermometry
- Masimo or Nellcor Pulse Oximetry
- Integrated thermal printer
- Immediate access to accurate patient vitals
- The wireless capability allows data transfer to an EMR
- Profiles control alarms, configured to specific workflows
- Display: 7" Colour LCD Touchscreen
- Memory (No. of Readings): 400

**AE1638** BP, SpO2 (Nellcor), Early Warnings

**AE1639** BP, SpO2 (Masimo), Early Warnings

**AE1640** BP, SpO2 (Nellcor), Temp (SureTemp), Early Warnings

**AE1641** BP, SpO2 (Nellcor), Temp (Braun), Early Warnings

**AE1642** BP, SpO2 (Masimo), Temp (SureTemp), Early Warnings

**AE1643** BP, SpO2 (Masimo), Temp (Braun), Early Warnings



Baxter



**AE1644** BP, SpO2 (Nellcor), Printer, Early Warnings

**AE1645** BP, SpO2 (Masimo), Printer, Early Warnings

**AE1646** BP, SpO2 (Nellcor), Temp (SureTemp), Printer, Early Warnings

**AE1647** BP, SpO2 (Nellcor), Temp (Braun), Printer, Early Warnings

**AE1648** BP, SpO2 (Masimo), Temp (SureTemp), Printer, Early Warnings

**AE1649** BP, SpO2 (Masimo), Temp (Braun), Printer, Early Warnings

## Accoson SA-110 Screening Audiometer

### Performs air conduction screening with advanced software

Housed in a small, lightweight casing the SA-110 includes the ability to quickly swap headsets (with calibration) and to easily move the unit between PC's.

It comes complete with a noise reduction headset, all cables, testing and batch utility analysis software, and a manufacturer's calibration certificate.

- Automatic test routines in line with British Society of Audiology
- Intensity range (-10dB to +110dB) for accurate assessment of patients from any age groups
- Frequency range (125Hz-8kHz) with four pre-selected frequency lists
- Audiograms can be stored locally on a PC or in a network
- Recall of stored results to screen/compare with current test
- A4 format printout of results in full colour
- Adaption of test protocol to suit requirement
- Export of results data in a form suitable for uptake by all modern database software
- Single or multiple pulse options

ACCOSON

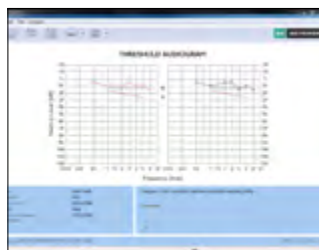

HCA011 Accoson SA-110 Screening Audiometer

## Accoson SA-90 Screening Audiometer

### Small, lightweight, portable & durable

Software is easy to use and automatically checks installation when switched on. The audiogram is displayed as the test proceeds and on completion can be accepted, printed out and saved to an archive.

If any thresholds are suspect, these points can be rechecked. The unique predictive analysis system intelligently examines hearing test results and will demonstrate to employees how their hearing will deteriorate if they do not wear protection or limit exposure.

- Simple & easy to use
- Small, lightweight & portable
- Automatic HSE categorisation of results
- USB linked and powered
- Has a range from - 10dB to +90dB
- Hearing loss prediction capabilities
- Options for Manual and Automatic testing
- Dimensions: 22 x 23 x 3.5 cm
- Weight: 0.5 Kg

ACCOSON



HCA010 Accoson SA-90 Screening Audiometer

## Electroacoustic Auto Response System

The EARS box has been designed to provide a quick and convenient way of **checking the performance of an audiometer.**

Check this prior to using it with subjects, in line with HSE recommendations, by providing accurate and consistent thresholds to the user.

Can be used with various audiometers

ACCOSON



HCA236 Electroacoustic Auto Response System

## Amplivox 116 Manual Audiometer

All purpose audiometer for primary care, school & industrial use

- Supplied with mains AC, Carry case & patient response switch
- Unique time-saving threshold retention feature.
- Totally portable (weighs 720g)
- Hearing level print-outs with optional printer
- -10 to 100 dBHL intensity range
- Pure, pulsed, continuous and warble tones
- Silent operation tone present function
- Optional printer and PC software Output



Free Demo



3 Year  
Warranty



**HCA041** 116 Manual Screening Audiometer

**HCA233.4** Sanibel Thermal Printer

**HCA060** Audibase PC Database Software

**HCA061** Replacement Carry Bag for 116

**HCA029** Amplivox Audiocups

## Amplivox 170 Automatic Audiometer

- Low price audiometer with both auto and manual audiometry
- Lightweight and compact, the Amplivox 170, weighs just 710g and is totally portable.
- Supplied with mains AC, carry case & patient response switch
- Results analysis with the optional Audibase software.
- Unique time-saving threshold retention feature.
- Hearing level print-outs with specified printer
- Totally portable (weighs 710g)
- -10 to 100 dBHL intensity range with silent operation



Free Demo



3 Year  
Warranty



**HCA070** 170 Automatic Audiometer

**HCA233.4** Sanibel Thermal Printer

**HCA060** Audibase PC Database Software

**HCA061** Replacement Carry Bag for 116

**HCA029** Amplivox Audiocups

## Amplivox 270+ Diagnostic Audiometer

A new two channel diagnostic audiometer designed for comprehensive audiometry requirements

- Two channel audiometry
- Automatic and manual air and bone testing (incl. masking)
- Masking assistant
- Binaural speech testing (Live and Recorded)
- Special tests: ABLB, Stenger, SISI, Tone Decay, HLS and MHA
- The test results are easily stored, printed and transferred to PC applications
- This device is supplied with Amplivox amplisuite PC software for electronic record creation



Free Demo



3 Year  
Warranty



**HCA055** 270 Replacement Carry Case

**HCA054** Masking Earpiece for 270

**HCA247** Talk Forward & Monitor Headset for 260/270

## Amplivox Otosure Auto Audiometer

The Amplivox Otosure is a PC-based automatic audiometer that provides a pro-active and portable solution to satisfy audiometric screening requirements.

- A reliable and robust 'plug and play' solution that can be used with desktop PC's, laptops and, or PC tablets
- PC Based automatic pocket-sized audiometer
- USB connectivity & 'Plug and play' functionality
- Test results analysis
- User definable recall facility
- Identification of 'at risk' personnel
- In-depth management analysis
- Requires PC running Windows 7 or higher operating system
- **Dimensions:** 120 x 86 x 28 mm
- **Weight:** 165 grams



Free Demo



3 Year  
Warranty



**HCA225** Amplivox Otosure PC-based Automatic Audiometer

**HCA029** Amplivox Audiocups



## Amplivox PC850 Auto Audiometer

Portable PC based audiometer that automatically measures and categorise hearing levels. Results can be used for statistical and trending analysis. Often used for mass screening programmes.

- Hybrid audiometer (PC-based and stand-alone)
- Manual and auto audiometry, incl. Békésy and computer test
- Integrated talk forward function
- Compatible with all leading occupational health databases
- **Dimensions:** 270 x 175 x 68mm
- **Weight:** 710 grams

**HCA212** Amplivox PC850 Auto Audiometer



Free Demo



3 Year Warranty

## Amplivox 250s Booth

A space saving preassembled acoustic booth which is practical & cost effective.

- Integral silenced ventilation and lighting
- Fitted with castors for complete mobility
- Integral seat (pre-assembled type)
- Complies with BSEN ISO 26189
- **730 x 990 x 1945 mm**
- **EXTRA DELIVERY CHARGES**



**HCA021** Amplivox 250s Booth

## Amplivox Audiocups

- Audiocups permit accurate pure tone audiometry in conditions of ambient noise too high for unshielded earphones and
- Can be easily fitted to any audiometer headset using standard AC earphones.
- Fit all Amplivox audiometers
- Audiocups are invaluable where a silent cabin or sound proof room is not available.



**HCA029** Amplivox Audiocups

## Amplivox Otowave Tympanometers

- Fast, accurate middle ear measurements
- Large graphic display on ergonomically design portable system
- Optional portable printer and PC interface
- No external power or data cables
- Programmable reflex test:
  - 102-1** Can be configured to 1 frequency (1KHz)
  - 102-4** Can be configured to 4 frequencies (500 - 1, 2 & 4KHz)

**HCA202** Otowave 102-1 Tympanometer

**HCA203** Otowave 102-4 Tympanometer



Free Demo



3 Year Warranty

**HCA202.1** IrDA PC port for NOAH module

**HCA204** High Speed Portable Thermal Printer

## Amplivox Otowave 302 Tympanometers

**A desktop solution for reliable and objective middle ear measurements.**

Choice of:

**302:** 226Hz tympanometry

**302+:** 226 & 1000Hz tympanometry

- Optimised, user selected measurement speeds
- Programmable ipsilateral and contralateral reflex tests
- Easy to read large graphics display
- Six user defined test protocols (302+)
- Internal memory
- PC connectivity to produce electronic records
- Portable with supplied carry case



**HCA233.2** Amplivox Otowave 302 Tympanometer

**HCA233.3** Amplivox Otowave 302+ Tympanometer

**HCA233.4** Sanibel Thermal Printer

## Gardiner Brown Tuning Forks

- Suitable for Rinnes Testing
- Electronically Tuned
- Integral finger grip for general practice & diagnostic use
- Hardened and tempered for notes of long duration
- Chrome plated forged Steel



**HCA046** Gardiner Brown Tuning Set

**HCA047** Fork 128Hz - Vibration

**HCA048** Fork 256Hz - Vibration & Sound

**HCA049** Fork 512 - Sound

**HCA050** Fork 1024 - Sound

**HCA051** Fork 2048 - Sound

**HCA052** Fork 4096 - Sound

## Rydel Seiffer Tuning Fork

CE marked and manufactured in the U.K Extremely portable and supplied with instructions. When vibrating, two triangles appear on the graduated scale of 0-8 which join together as the amplitude decreases.

When the patient says they are unable to feel the vibration the scale is read at the apex of the single triangle formed from the initial two triangles allows quantifiable assessment of vibration perception in the feet of diabetic patients



**CH257** Rydel Seiffer Tuning Fork

## Interacoustics Paediatric Audiometer

High-quality paediatric free field audiometer designed for trained healthcare professionals testing young children.

- One hand operation with silent presentation switch
- White noise stimulus for improved sensitivity
- Warble Tone & Narrow Band Noise
- Flashing Light Stimulation
- Robust, Lightweight
- Uses standard AA Batteries
- Automatic Battery Switch & Automatic Battery Indication
- **Dimensions:** 25 x 7 x 5 cm / **Weight:** 1.3 kg

### PA5 Tests Overview

Auropalpebral Reflex (APR)

Conditioned Orientation Response (COR)

Visual Reinforcement Audiometry (VRA)

**Interacoustics**



**HCA237** Interacoustics PA5 Paediatric Free Field Audiometer

**HCA241** TDH39 Noise-Reducing Audiometric Headset

## Interacoustics Titan Tympanometer

Titan is a modular tympanometer platform that lets you combine the tools you need with handheld freedom and full flexibility.

- Superior, professional aesthetics & Extremely light design
- Patient-centred - multiple probe & transducer configurations
- Handheld and PC mode for full flexibility
- Supreme usability through storage of calibration values in probe and ID-transducers
- Detailed investigation at the onset of the reflex
- Optional high frequency probe tones (678, 800 & 1000Hz)
- Shoulder unit and probe indicator LED
- User customisable controls & Protocol upload
- **Dimensions:** 6 x 6 x 28 cm
- **Weight:** 360g
- **CE-mark:** Yes



**Interacoustics**   1 Year Warranty

**HCA242** Interacoustics Titan Screening Tympanometer

**HCA246** Titan Cradle - Charging & Connection to PC

**HCA243** High Frequency Probes Tones for Titan

**HCA245** Sanibel MTP-II Thermal Printer - Bluetooth

**HCA244** Short Probe Extension

## Interacoustics AS608 Audiometer

A portable screening audiometer - ideal for use wherever quick hearing screening evaluations are performed.

- Customise frequency test selections
- Output levels from -10dB to 100dBHL
- Pure tone, warble tone and pulsed tone
- Silent stimulus switch and battery status indicator
- **Dimensions:** 22.5 x 18 x 5.5 cm / **Weight:** 1 kg

### The AS608e also includes :

- Hughson Westlake automatic pure tone test procedure.
- Patient response switch
- Talk Forward
- PC-integration

**Interacoustics**



**HCA238** Interacoustics AS608 Portable Screening Audiometer

**HCA239** Interacoustics AS608e - Extended Version

**HCA240** Medically Approved External Power Supply

**HCA241** TDH39 Noise-Reducing Audiometric Headset

## Prestige Medical Alpha Autoclaves

The Alpha non-vacuum autoclave is specifically designed for dental practices. Easy to use, reliable and cost-effective, with outstanding performance. A Class N non-vacuum sterilizer. With a host of features to help simplify and streamline sterilization of re-usable instruments, fully supported by Prestige Medical's award-winning customer service and technical service support.

- Robust integral stainless steel waste water tank.
- High performance cooling system for faster cycle times.
- 16/22 litre chamber capacity
- Multiple water feed and drain options
- Clear, backlit LCD display with simple user friendly 6 push button control system
- Supplied as standard with an integrated data logger and SD memory card



**STR413** Alpha 16L Non-Vac with integrated data logger

**STR414** Alpha 22L Non-Vac with integrated data logger

**STR418** 1L Autoclave Cleaner

**STR417** Helix Control Indicators - 1 x50 Non-adhesive

## Prestige Medical Advance Autoclaves

Provides Class B vacuum and Class N non-vacuum cycles in the same unit. Advance Pro is a Class B sterilizer available in 16 or 22 litre capacity units, they offer superior performance and all units are fully supported by Prestige Medical's award-winning customer service and technical service support.

- Unique FlexiRack tray and load management system
- Robust integral stainless steel waste water tank and a high performance cooling system for faster cycle times
- Multiple water feed and drain options available
- Clear, backlit LCD display with simple user friendly
- VSI (Visual System Indicator). Six cycle stage indicator lights
- Supplied with an integrated data logger and SD memory card
- 6 push button control system



**STR416** Advance Pro 16L with integrated data logger

**STR415** Advance Pro 22L with integrated data logger

**STR418** 1L Autoclave Cleaner

**STR417** Helix Control Indicators - 1 x50 Non-adhesive

## Prestige Medical Ultraclean

A popular choice for dental practices needing to meet best practice standards as defined by the HTM 01-05 guidelines. Now with faster cycle times, glass view panel and interior illumination.

- 35 minute 'Quick Cycle' for faster processing of instruments
- Viewing window and illuminated chamber allows a simple check to ensure the machine is operating correctly
- Fully compliant to EN 15883 and HTM2030 - the recommended 'best practice' standard
- Unique air gap prevents backflow pollution to ensure the safe disposal of contaminated fluid as required by BS EN 1717:2001
- High load capacity, one of the highest capacities on market
- Forced hot air drying removes all moisture on instruments
- Self-dosing detergent delivers consistent results



**STR391** Ultraclean 3 B/T

**STR392** Ultraclean 3 U/B

**STR420** Ultraclean 3500 U/B

**STR421** Autoclave Printer

**STR422** Autoclave Data Logger

**STR423** 3x 1L Detergent (U/Clean)

## Prestige Medical Upright Autoclaves

Designed to give you the most cost effective sterilization solution. Simplicity itself to use, fully automatic with a simple, one touch operation and is guaranteed to meet your needs.

### Classic 134 Model with Gauges

- 134°C with minimum sterilizing time of 3 minutes
- **Max instrument length:** 228mm
- **Max load weight:** 3kg

### Classic 2100 Model

- 126°C with an 11 minute cycle
- **Max instrument length:** 228mm
- **Max load weight:** 3kg



**STR998**



**STRO22**

**STR998** Classic 134 with Gauges Standard 9L

**STRO22** Classic 2100 Standard - 9 litre

**STRO24** Classic 2100 Extended - 12 litre

**STR419** Helix Test Type for Prestige Medical - 10

**STR998.1** Sealing Gasket (Set of 4)

## Elite Doctor's Bag



### Medical equipment and supplies are not included

- The large outer file-folder pocket padded and has capacity to transport a laptop of up to 15inch.
- Two net pockets for instruments.
- Includes trolley band and external ID badge holder.
- Main compartment with 4 removable pockets with transparent window.
- Ergonomic padded handle.
- Zipper for padlock.
- Isothermal ampoule holder - 38 elastic bands of various sizes.
- Large flat pocket for documents.
- Dimensions: **17 x 40 x 30cm**
- Weight: **2.6 kg**
- Maximum Recommended Contents Weight: **5kg**

**HCB208** Elite Doctor's Bag – Black Twill Nylon

## Elite Street's Bag



### Medical equipment and supplies are not included

- Large capacity multifunctional front compartment for personal items (laptop, tablet, documents, pens, etc.)
- 300D High Tenacity. Bitone Polyester.
- Main body with 3 removable transparent front compartments for instruments and material.
- Isothermal ampoule holder - 38 elastic bands of various sizes.
- Panel with elastic bands of different sizes for curing material
- Flat interior pocket for large dressings
- Band for use with trolley and card holder on the rear panel
- Hidden backpack straps on the back of the briefcase
- Measures: **40 x 30 x 16 cm**
- Weight: **2.1 kg**
- Maximum recommended contents weight: **5 kg**

**HCB209** Elite Street's Home Care Bag

## Elite Nursing Bags



### Medical equipment and supplies are not included

- Lightweight, compact size - ideal for a comfortable daily use
- Designed to satisfy the equipment transportation needs of those professionals specialising in family/community health.
- Zipper for padlock.
- Interior adaptable to the needs of the user thanks to the padded velcro detachable dividers.
- Manufactured from 420D Polyester. Washable.
- Top carry handle & Removable shoulder strap.
- Back pocket that can be turned into a trolley band.
- Two wide front pockets.
- Two internal, flat, net pockets for instruments.
- Available in blue or pink.
- Isothermal compartment for 38 ampoules.
- Dimensions: **14 x 26 x 35 cm**
- Weight: **1.3 kg**

**HCB210** Community Nursing Bag - Blue

**HCB211** Community Nursing Bag - Pink

## Elite GP's Lightweight Bag



### Medical equipment and supplies are not included

- Light, resistant and anti-slip material.
- Zipper with padlock fastener.
- Padded handle with velcro fastener.
- Two large pockets with elastic bands.
- Flat pocket for documents.
- Isothermal compartment for 41 ampoules.
- Honeycomb interior with detachable velcro dividers.
- Manufactured from 600D Polyester. Washable.
- Interior panel with elastic bands.
- Other colours are available - Contact us for details.
- Measures: **40 x 21 x 25 cm**
- Weight: **1.3 kg**
- Maximum recommended contents weight: **3.5 kg**

**HCB212** Elite GP's Lightweight Medical Bag

## Elite Emergency Bag



### Medical equipment and supplies are not included

- Practical, light and organised emergency bag
- Two adjustable inner separators with rack pocket in the flap to ease the organisation of sanitary material.
- Three external pockets, two are diaphanous and one is at the front, internally subdivided and with elastic holding bands.
- High resistance zippers for use with locks.
- Manufactured from coated 600D Polyester.
- With reinforced handles, shoulder straps & reflecting strips.
- Other colours are available – Contact us for details.
- Measure Main Body: **44 x 25 x 27 cm**.
- Weight: **1.2 Kg**

**HC B214** Elite Emergency Bag

## Elite First Aid Bag



### Medical equipment and supplies are not included

- Keep all materials for applying first aid in many environments.
- Adjustable inner layout thanks to the removable dividers.
- Elastic bands on internal wall hold instruments or equipment.
- Wide side pockets on both ends, include elastic bands and mesh pockets for holding instruments or equipment
- Manufactured from 600D Polyester.
- Removable shoulder strap.
- Velcro closing carry handle at top.
- Other colours are available – Contact us for details.
- Dimensions: **37 x 25 x 20cm**
- Weight: **0.75 kg**
- Maximum recommended contents weight: **3 kg**

**HC B213** Elite First Aid Bag

## Elite Paramed XL Backpack



### Medical equipment and supplies are not included

- MOLLE system in all external bag sections, both frontal and lateral, to anchor additional pockets or diverse material.
- Internal pocket for hydration bag and tube extraction hole.
- Upper front pocket and removable side handle
- Multi-purpose padded front panel with defibrillator capacity.
- Removable central flap with multiple rubber bands on one side and transparent large capacity pockets on the other.
- Isothermal ampoule with capacity for 44 ampoules.
- Quick-release system for emergency situations.
- Removable waist pack for maximum support at the waist.
- Rear padded panel completely to ensure maximum comfort.
- Dimensions: **32 x 52 x 28 cm**
- Weight: **3.50 kg**
- Capacity: **46.5 L**

**HC B227** Elite Paramed XL Tactical Rescue Backpack - Red

## Elite Emergency Trolley Bag



### Medical equipment and supplies are not included

- Large external pocket on the front
- Concealed lockable telescopic trolley handle
- High impact plastic wheels
- Two ergonomic rubber carry handles
- Hide-away zipped pocket for backpack shoulder straps
- Transparent outer pocket
- Reflective, high visibility tape to all sides
- Heavy duty zippers with large pullers for easy use
- Padded, semi-rigid construction
- Dimensions: **31 x 35 x 61 cm**
- Weight: **6.20 kg**
- Recommended maximum content: **25kg**

**HC B223** Elite Emergency Respiratory Trolley Bag - Red

## Health-Care Deluxe Medibag



- Waterproof and very lightweight, padded black canvas bag
- Adjustable internal dividers in main compartment
- Removable shoulder strap with padding
- 2 pouch pockets on face of front pocket
- 2 side pockets on the bag
- **Dimensions:** 240 x 375 x 115mm
- **Weight:** 1 kg

**HCB027** HCE Deluxe Medibag

## District Nurses Case



- Black briefcase design in Shockproof ABS
- Die cut foam in lid with two containers
- Black durable moulded base
- Supplied with key locks
- Complete with screw top bottles & clear container
- **Dimensions:** 41 x 31 x 12 cm
- **Weight:** 2.2 kg

**HCB012** District Nurses Case

## Med 1 GP Case



- Lid has 3-part document pocket with phials in foam behind
- Base has a deep moulded tray with adjusting foam inserts
- Template and scalpel supplied
- Triple Frame ABS Case
- Secure toggle locks and keys
- **Dimensions:** 46.5 x 33.5 x 12.75 cm
- **Approximate Weight:** 3 kg

**HCB016** Black Case

**HCB016.1** Silver Case

## Med 16 GP Supreme Case



- Lid has 3-part document pocket with phials in foam behind
- The opening lid has a false compartment with 3-part document pockets to the base side.
- The base has a moulded tray with moveable divisions
- Secure toggle locks and keys
- **Dimensions:** 46 x 34 x 16.5 cm
- **Approximate Weight:** 3.5 kg

**HCB017** Black Case

**HCB017.1** Silver Case

## Med 17 GP Superior Case



- Lid has 3-part document pocket with phials in foam behind
- The base can be closed, providing a useful writing area
- The base has a deep moulded tray with moveable divisions
- Durable triple frame ABS Case
- Supplied with secure toggle locks and keys
- **Dimensions:** 46 x 34 x 16.5 cm
- **Approximate Weight:** 4 kg

**HCB019** Black Case

**HCB019.1** Silver Case

## Med 8 GP Deluxe Case



- Reliable toggle locks with keys
- Triple Aluminium frame with strong ABS moulding
- Deep moulded base tray with moveable divisions & cover
- False lid with a pocket to the underside, foam pad on top
- Template and scalpel supplied for customer cutting
- **Dimensions:** 46 x 34 x 16.5 cm
- **Approximate Weight:** 4 kg

**HCB018** Black Case

**HCB018.1** Silver Case

## New Gear Guardian



### NEW GEAR MEDICAL

#### Medical equipment and supplies are not included

- Made from antimicrobial 1680D ballistic polyester
- Two zipped interior compartments meet HIPAA compliance with locking zippers (when used with New Gear secure locks)
- Two roomy front pockets that snap closed with top flap
- Two side pockets for water bottle or accessories
- Large pocket on back panel opens to lay flat for work surface
- Detachable and adjustable strap with sliding shoulder pad ensuring user comfort
- Easy clean fabric - Simply wash off with soap and water
- Non-slip feet to protect bottom of bag
- Rear trolley pocket for wheeled trolley (see accessories)
- Bring it as a carry-on on your flights: **14.50 x 12 x 6inch**
- Very light weighing **only 2lbs.**

HCB197 The Guardian - Trusted Medical Shoulder Bag

## New Gear Guardian 2.0



### NEW GEAR MEDICAL

#### Medical equipment and supplies are not included

- Made from antimicrobial 1680D ballistic polyester
- Messenger-bag style with comfortable, adjustable straps
- Three zipped interior compartments meet HIPAA compliance with locking zippers (when used with New Gear secure locks)
- Two large front pockets with self-closing flaps
- Two side pockets for water bottle or accessories
- Large pocket on back panel opens to lay flat for work surface
- Non-slip feet and convenient top satchel handle
- Front zipped privacy pocket for phone, wallet or ID
- Rear trolley pocket for wheeled trolley (see accessories)
- Easy clean fabric - Simply wash off with soap and water
- Bring it as carry-on on your flights: **14.50 x 12 x 7inch**
- Very light weighing **only 2lbs.**

HCB198 The Guardian 2.0 - Deluxe Medical Bag

## New Gear Attache' Antimicrobial Bag



### NEW GEAR MEDICAL

#### Medical equipment and supplies are not included

- Made from antimicrobial 1680D ballistic polyester
- Easy clean fabric - Simply wash off with soap and water
- Opens flat to view and access supplies, large top zip bag to carry and organize your inventory
- Front zip pocket for convenient quick access
- Carry with handles, shoulder strap or mount on trolley
- Rain or shine, this bag will be OK and is water-resistant
- Adjustable and detachable strap with sliding shoulder pad
- Supports use with a wheeled trolley (purchased separately)
- Reflective bottom trim for visibility and safety
- Non-slip feet to protect the bottom of the bag
- Bag Dimensions: **18 x 12.50 x 4inch**
- Very light at **only 3 lbs.**

HCB216 Attache' Antimicrobial Doctor Bag - Drug Rep Bag

## New Gear Wheeled Traveller



### NEW GEAR MEDICAL

#### Medical equipment and supplies are not included

- Easy clean fabric - Simply wash off with soap and water
- Made from antimicrobial 1680D ballistic polyester
- Removable adjustable Shoulder Strap and a grip handle
- 4 open sections, 2 for medical equipment, 1 for laptop and files and 1 for mobile office equipment
- Multiple pockets to easily find equipment and supplies
- Padded sections to protect contents
- Secure locking zipper meet HIPAA compliance with locking zippers (when used with New Gear secure locks)
- Rear fold down compartment for a clean work surface
- Front reflective strip design
- Overall bag dimensions: **16 x 7.5 x 12.5inch**
- Lightweight at **only 4lbs.**

HCB200 The Traveller - Rolling Medical Bag

## New Gear Aegis



### NEW GEAR MEDICAL

#### Medical equipment and supplies are not included

- Extremely spacious trunk organizer with room for dozens of individual compartments
- Made from antimicrobial 1680D ballistic polyester
- Easy clean fabric - Simply wash off with soap and water
- Opens flat to view and access supplies
- Large top zip bag to carry and organize inventory
- Front zip pocket for convenient quick access
- Second front double-zip office compartment with file dividers, pen pockets and other organizing pockets
- Adjustable and detachable strap with sliding shoulder pad
- Rear trolley pocket for wheeled trolley (see accessories)
- Reflective trim and non-slip feet at bottom for protection
- Overall bag dimensions: **18 x 12.5 x 7.25inch**
- Very light at **only 2lb.**

**HCB201** The Aegis – Medical Supply Organizer

## New Gear Trustee Waist Organizer



### NEW GEAR MEDICAL

#### Medical equipment and supplies are not included

- Access your go-to gear right on your hip
- Numerous strategic pockets in different sizes
- Full length rear zippered pocket
- Adjustable belt for any hip or waist size
- Carabiner to hold your keys, tape, etc.
- Made from antimicrobial 1680D ballistic polyester
- Easy clean fabric - Simply wash off with soap and water
- Easy-access front pockets for quick access to key equipment
- Convenient large front zip pocket
- Secure locking zipper for HIPAA compliance (When used with New Gear Medical locks)
- Rain or shine, this bag will be OK and is water resistant
- Bring it anywhere with convenient dimensions: **14 x 7.5inch**
- Very light at **only 1lbs.**

**HCB202** The Trustee Black – Medical Waist Organizer

**HCB202.1** The Trustee Pink – Medical Waist Organizer

## New Gear Shield Backpack



### NEW GEAR MEDICAL

#### Medical equipment and supplies are not included

- Backpack-style with comfortable, adjustable straps
- Made from antimicrobial 1680D ballistic polyester
- Easy clean fabric - Simply wash off with soap and water
- Easy-access pockets for quick access to key equipment
- Convenient large front zip pocket
- Secure locking zipper meet HIPAA compliance with locking zippers (when used with New Gear secure locks)
- Front-zip phone pocket with clear ID window
- Sturdy laptop and tablet compartment
- Reflective bottom-trim for visibility
- Bring it as carry-on on your flights: **13 x 17 x 5inch**
- Very light weighing **only 3lbs.**

**HCB199** The Shield – First Aid / Small Trauma Bag

## New Gear Accessories



**HCB204** Medical Bag Trolley

**HCB206** Secure Combination Lock

**HCB203** Mesh Accessory Bags – Set of 3

**HCB205** Reuseable Antimicrobial Sheet

**HCB207** USB Mini Recharge Flashlight

**NEW GEAR MEDICAL**



## Hyfrecator 2000

In terms of efficiency and cost-effectiveness, there is little to compare with the Hyfrecator 2000, the latest and best model in a long line of Hyfrecators. The Hyfrecator is commonly used by dermatologists & GPs in conjunction with curettage for the destruction of small well-defined skin cancers such as basal cell carcinoma. Also for the treatment of benign moles, common viral warts, seborrheic warts, skin tags, solar keratoses, spider naevi, telangiectasias, venereal warts, etc.

- **Potential applications include:** Dermatology, Vasectomy, Plastic Surgery, Proctology, Gynaecology, GU, Ophthalmology, Urology, Vasectomy, Otolaryngology, Maxillofacial, Dental and Oral Surgery
- **Supplied with:** patient plate, reusable hand switching pencil, starter box of non-sterile electrolase tips (blunt & sharp), wall mount kit, operators manual and training CD
- Digital one-tenth incremental low power mode give precise control in the critical 0 to 10 watt range, high power mode has a range of 0-35W
- Solid state Electrodesiccation, Fulguration and Coagulation

**ELS036.1** Annual Hyfrecator 2000 Service

**The FS model** includes a footswitch to enable the operator to control the on/off power with their foot.

**The FSB model** includes reusable bipolar forceps & cable to be used for coagulation and haemostasis during procedures. This model also includes the footstool & button-less handle.



**ELS036** Hyfrecator 2000

**ELS037** 2000 FS with Footswitch

**ELS038** 2000 FSB with Bi Polar Forceps & Footswitch

## Hyfrecator 2000 Smoke Package

Get the latest Hyfrecator 2000 FS, a smoke evaluator system and a range of electrosurgery accessories worth over £300, for 10% less than list price

### This package includes:

- Model 2000 Hyfrecator with Footswitch
- Patient plate & Cable
- Handle & Cord
- Acu-Evac Smoke Evacuation Unit
- Main filter, Nozzle, Tubing, Footswitch, Mobile stand and Boom arm all for Acu-Evac
- Ball Electrode Disposable sterile - 40 Pack
- Blunt Electrolase Tip Sharp Sterile - 50 Pack
- Electrolase tip Sharp sterile - 50 Pack
- Sterile Sheath for Handle and Cord - 25 Pack
- IEC Mains Y Cable with 12A UK Plug



**ELS038.1** Hyfrecator 2000 Smoke Package

## Surtron 120 Electrosurgery Unit

Ideal for the treatment of a variety of skin conditions. This unit will give you the flexibility of cut, coagulation & a combined setting.

- Pure cut, CUT
- Coagulated cut, BLEND
- Superficial coagulation, COAG FORCED
- Deep coagulation (without carbonisation), COAG SOFT
- Bipolar coagulation, BIPOLAR (with adaptor)

### The 120 comes complete with these re-usable accessories:

- Ball electrode length 6 cm (pack of 3)
- Blade electrode length 7 cm (pack of 3)
- Bipolar adaptor
- Handle for micro-surgical needle & surgical handle holder
- Needle electrode length 7cm (pack of 3)
- Needles for micro-surgery length 1cm (pack of 5)
- Reusable handle with finger switches 3mt
- Steel neutral electrode size 120x160 mm

**ELS075** Surtron 120 Unit

**ELS084.1** Adaptor for Bi-Polar forceps (ELS084 See Below)

**ELS084** Bi-polar forceps with integral cable - 20pk



**ELS044** 110cm Reusable Bi Polar Forceps & Cable (Requires FS)

**ELS083** Fine Wire Epilation electrode 0.1mm - 30pk

**ELS076** Coag ball 5mm electrode shaft length 5cm - 40pk

## Battery Cautery & 4 tips

Battery operated cautery unit including 4 varying tips for domiciliary and basic applications.

- Suitable for domiciliary use & basic application minor surgery
- All sizes of spare cutters available
- Battery operated with choice of handles
- Fingertip power control
- Simple push connection for tips
- **Supplied complete with:** 2 large burners, 2 small burners & foam lined storage case

<b>ELS084</b>	Bi-polar forceps with integral cable - 20pk
<b>ELS044</b>	110cm Reusable Bi Polar Forceps & Cable (Requires FS)
<b>ELS058</b>	Battery Cautery & 4 Tips - Type AA Handle
<b>ELS084.1</b>	Adaptor for Bi-Polar forceps (ELS084 See Below)



<b>White Tip</b>		<b>Coagulation Ball</b>
<b>Blue Tip</b>		<b>Straight Cutter</b>
<b>Green Tip</b>		<b>Needle/Cold Point</b>
<b>Yellow Tip</b>		<b>Angled Cutter</b>
<b>Red Tip</b>		<b>Loop Cutter</b>



### Cautery Tips:

<b>ELS063.1</b>	Cautery Cutter Co-agulation Ball - White
<b>ELS063.2</b>	Cautery Cutter Straight Cutter - Blue
<b>ELS063.3</b>	Cautery Cutter Needle/Cold Point - Green
<b>ELS063.4</b>	Cautery Cutter Angled Cutter - Yellow

## Battery Cautery & 5 Tips

Battery operated cautery unit including 5 varying tips for use in multiple cautery applications, this product includes a protective carry case and batteries.

- Platinum Iridium Long Lasting Tips, non oxidising
- Fully autoclaveable handle and tips (excluding batteries)
- Battery operated model
- Complete in protective pocket case with batteries
- Suitable for light duty cosmetic surgery
- Chrome-brass handle with contact control & teflon connector

### Includes 5 tips:

Coagulation Ball, Straight Tip, Angled Tip, Loop Cutter & Cold Point

<b>ELS062</b>	Battery Cautery & Electrosurgery + 5 Tips
<b>ELS064</b>	Replacement Handle For ELS062
<b>ELS063.5</b>	Cautery Cutter Loop Cutter - Red
<b>ELS063.6</b>	Disposable Cautery Cutter Co-agulation Ball - White
<b>ELS063.7</b>	Disposable Cautery Cutter Straight Cutter - Blue
<b>ELS063.8</b>	Disposable Cautery Cutter Needle/Cold Point - Green

## Light Duty Rechargeable Cautery Unit

For GPs who require an easy to use, reliable and highly portable cautery system. This complete cautery unit is the perfect set that meets your needs.

### This set is supplied with:

- Battery operated handle & Portable carry case
- Mains charger & Rechargeable battery
- 2x SEJA5281, Cautery burners
- 2x SEJA5283 Cautery burners
- Simple button operation handle
- Slimline handle with safety features

<b>JC150</b>	Light Duty Battery Operated Cautery & Electrosurgery Unit
<b>ELS055</b>	Rechargeable Ni-mh Battery 1.2V
<b>ELS002.1</b>	Single Use Cautery Burner - Puncture Point - 47mm
<b>ELS004.1</b>	Single Use Cautery Burner - Straight Cutter - 47mm
<b>ELS005.1</b>	Single Use Cautery Burner - Coagulation Cutter - 47mm



<b>JA5288</b>	Cautery Burner - Coagulation Ball - 47mm
<b>JA5289</b>	Cautery Burner - Cold Point - 56mm
<b>JA5280</b>	Cautery Burner - Coagulation Loop - 47mm
<b>JA5284</b>	Cautery Burner - Straight Cutter - 120mm
<b>JA5285</b>	Cautery Burner - Coagulation Ball - 120mm
<b>JA5286</b>	Cautery Burner - Ring Cutter - 120mm
<b>JA5287</b>	Cautery Burner - Puncture Point - 120mm
<b>JA5290</b>	Cautery Burner - Coagulation Loop - 120mm

## Medical Consumables

We stock a large range of medical consumables for a range of healthcare environments and everyday uses. These include a vast range of products typically used on a day to day basis for a whole host of application in a clinical settings:

- Bandages, dressings & plaster of paris
- Clothing, gloves & PPE
- Washroom equipment & accessories
- Couch rolls

Contact our helpful sales team for assistance with your requirements. See this product range online: [www.hce-uk.com/consumables](http://www.hce-uk.com/consumables)

- Oxygen masks & tubing
- Suturing equipment
- Sharps disposal units
- Needles & syringes



## Cryosuccess

A simple and effective handheld cryotherapy device for accurate treatment of skin lesions making it ideal for general practice, dermatology, podiatry and minor surgery applications.

Incorporates an improved safety design which allows easy on/off fitting of the cartridge. The device can be kept ready for use at any time. The cartridge can be removed at any time, for longer term storage or transport and then rapidly reconnected.

To apply the cryogenic liquid gas, the dispenser tip is touched against the skin surface, escaping liquid gas directly touches the surface before a gaseous phase transition takes place.

### Pack Comprises:

1 x CryoSuccess, 1mm application tip, protective cap, cartridge, pin and instructions, contained in an ABS protective case

### Features:

- Cost per treatment 50p on average
- Simple pencil type grip for easy use & accurate application
- Freezes to  $-89^{\circ}\text{C}$  and to a depth of 3mm
- Level of cold generated adjusted by the rate at which the button is depressed
- Using Nitrous Oxide cartridges avoids all of the storage and transport problems associated with liquid nitrogen



Condition	Treatment Time
Acne	4-6 Seconds
Keratosis Actinica	5-7 Seconds
Age Pigments	1-2 Seconds
Basiloma	8-9 Seconds
Cavernous Angioma	4-6 Seconds
Granuloma Anulare	5-6 Seconds
Hemangiolympangioma	6-8 Seconds
Juvenile Warts	3-4 Seconds
Keloids	4-6 Seconds
Senile Keratoma	7-8 Seconds
Condyloma	8-12 Seconds
Lentigo Maligna	4-5 Seconds
Lentigo Senile	2-3 Seconds
Nevus Pigmentosus	8 Seconds
Plantar Warts	15-20 Seconds
Solar Keratosis	4-5 Seconds
Seborrhoeic Warts	6-8 Seconds
Verruca Vulgaris	8-10 Seconds
Soft Fibroma	4-5 Seconds

HCG054 Cryosuccess Unit

HCG055 Replacement Cartridge 23.5g

## CRY-AC® Units

The world's leading manufacturer of handheld, liquid nitrogen devices. Our units provide the ultimate in controlled application.

- Slender, fingertip trigger for maximum control and ease of viewing, this rotates easily for left-hand users
- Patented Safety Autovent maximizes safety by allowing the internal pressure to gradually vent as the cap is unscrewed
- Streamlined relief valve maintains a constant operating pressure to ensure consistent and accurate freezing
- Polypropylene cover and collar insulates the user's hand
- Stainless steel and brass construction for long life
- Sturdy Polypropylene base for extra stability
- 3 year limited warranty

HCG058 CRY-AC® Unit

HCG059 CRY-AC-3® Unit

**CRY-AC** – Larger size for greater capacity & longer holding time

- **Capacity:** 16 oz. (500ml)
- **Height:** 286mm
- **Weight Full:** 895g
- **Weight Empty:** 540g
- **Static Holding Time:** 20-24hr

**CRY-AC-3** – Smaller size for easier handling & transport

- **Capacity:** 10oz. (300ml)
- **Height:** 215mm
- **Weight Full:** 715g
- **Weight Empty:** 490g
- **Static Holding Time:** 10-12hrs



## Brymill LN2 Storage & Withdrawal Equipment

Known industry-wide as the gold standard in LN2 equipment, all Brymill storage equipment comes with a 3 year warranty.

We also supply a wide range of Brymill LN2 accessories and safety equipment.

### Roller Base

Recommended for dewars of 20L+



### Safety Gloves

Available in Small, Medium & Large



### Dewar Cap

Replacement for worn or damaged dewar caps



### Filters for withdrawal device

Sturdy filtration device for LN2 units

Product Code	Capacity	Static Hold Time	Weight Empty	Weight Full
HCG061	5 Litre	4-5 Weeks	8 lbs.	17 lbs.
HCG062	10 Litre	6-8 Weeks	13 lbs.	30 lbs.
HCG063	20 Litre	8-12 Weeks	19 lbs.	53 lbs.
HCG064	20 Litre	200 Days (LL)	19 lbs.	53 lbs.
HCG065	30 Litre	14-16 Weeks	26 lbs.	77 lbs.
HCG066	50 Litre	14-17 Weeks	34 lbs.	123 lbs.



### Liquid Nitrogen Withdrawal Tube

Simple and efficient way to extract liquid nitrogen from your storage dewar. Conveniently fills one CRY-AC® unit at a time. Tube is removed from dewar after each use. Offers instant pressurization. Includes a filter that helps clean the LN2 before it is withdrawn.



### Liquid Nitrogen Withdrawal Device

Conveniently fills multiple CRY-AC® units at a time. Device affixes to top of dewar (i.e., is not removed after each use), has a simple on/off control, and works like a faucet. Includes a filter that helps clean the LN2 before it is withdrawn.

**HCG061** 5 Litre Dewar

**HCG062** 10 Litre Dewar

**HCG063** 20 Litre Dewar

**HCG064** Long Lasting 20 Litre Dewar

**HCG065** 30 Litre Dewar

**HCG066** 50 Litre Dewar

**HCG067** Withdrawal Device

**HCG068** Withdrawal Tube

**HCG069** Filter for Withdrawal Device #502

**HCG070** Filter for Withdrawal Device #503

**HCG078** Dewar cap

**HCG079** Roller Base for 20ltr Dewar

**HCG080** Roller Base for 30ltr Dewar

**HCG081** Roller Base for 50ltr Dewar

**HCG071** Mid Arm Length Cryo Gloves - Small

**HCG072** Mid Arm Length Cryo Gloves - Medium

**HCG073** Mid Arm Length Cryo Gloves - Large

**HCG074** Elbow Length Cryo Gloves - Small

**HCG075** Elbow Length Cryo Gloves - Medium

**HCG076** Elbow Length Cryo Gloves - Large

**HCG077** Safety Goggles

## Cryospray 59

Designed to freeze tissue to around -50°C to achieve an effective result. Other Cryogenic treatments can reduce the temperature of the tissues to -185°C which is more painful.

- Delivers up to 60 applications
- Designed to freeze tissue to temperatures of around -59°C
- Dispensing head designed for greater control
- Includes 12 cotton wool tipped applicators for the treatment of small verrucas and 3 straw applicators for general use.

**HCG035** Cryospray 59

**HCG035.1** Cotton Buds for Cryospray 59 - 12pk

**HCG035.2** Straws for Cryospray 59 - 12pk



## HEINE DELTAone Dermatoscope

Small on the outside, big on the inside – this mobile masterpiece is taking medical professionals by storm. The crystal-clear image was accomplished using the new achromatic HEINE optical system.

What's more, it produces extraordinary colour rendering, due to the quality of our LEDHQ. Examinations are now particularly comfortable due to the polarisation allowing doctors to work glare-free and without disrupting reflections. These three features – clarity, LEDHQ and non-reflective working – are what turn the DELTAone into a vital tool to carry in your pocket wherever you go.

- Field of view of real 21mm (lens 22mm)
- Custom light intensity: 3 degrees of luminous intensity
- 10x magnification
- Switch between polarised and non-polarised light at the touch of a button = toggle function.
- No cross-contamination: autoclavable contact plate with scale
- Maintenance-free due to our dustproof design
- Dioptre compensation
- Rechargeable battery with Li-ion technology: no memory effect; you can safely recharge the battery regardless of its charge state
- Can be used with the HEINE DERM app, available for free on the Apple App Store
- Wireless connection via iPhone and WLAN with the HEINE Cube System

**HCD318** Small contact plate for DELTAone

**HCD320.1** Universal Smartphone Adaptor for DELTA Dermatoscopes

**HCD320.5** Mounting Case iPhone 12 Pro for DELTA Dermatoscopes



**HCD316**

**HCD317**



**Power supply and protective case included**

**Shown mounted to iPhone**



**HCD316** Black/Silver – with contact plate, scale, USB Cord, power supply and case

**HCD317** White/Silver – with contact plate, scale, USB Cord, power supply and case

**HCD320.4** Mounting Case iPhone 11 for DELTA Dermatoscopes

**HCD321** Mounting Case iPhone X for DELTA Dermatoscopes

**HCD322** Mounting Case iPhone XR for DELTA Dermatoscopes

## HEINE DELTA 30

Not only would our new high-end dermatoscope win any beauty pageant; it stands out due to the best imaging we've ever developed. Combined with a field of view measuring a veritable 30 millimetres and unprecedented colour rendering, in LEDHQ of course. Polarisation provides glare-free and non-reflective working conditions. Above all else, it is comfortable to operate with its angled, ergonomic design and intuitive control.

- Glare-free and non-reflective working conditions thanks to polarisation
- Custom light intensity: 3 degrees of luminous intensity
- 10x magnification
- Switch between polarised and non-polarised light at the touch of a button = toggle function.
- No cross-contamination: autoclavable contact plate with scale
- Maintenance-free due to our dustproof design
- Dioptre compensation
- Rechargeable battery with Li-ion Tech: no memory effect; you can safely recharge the battery regardless of its charge state
- Can be used with the HEINE DERM app, free on the Apple App Store
- Wireless connection via iPhone and WLAN with the HEINE Cube System

**HCD320.1** Universal Smartphone Adaptor for DELTA Dermatoscopes

**HCD320.5** Mounting Case iPhone 12 Pro for DELTA Dermatoscopes

**HCD321** Mounting Case iPhone X for DELTA Dermatoscopes

**HCD322** Mounting Case iPhone XR for DELTA Dermatoscopes



**Shown mounted to iPhone**

**HCD332**



**HCD328** DELTA 30 – with contact plate, scale, USB Cord, power supply and case

**HCD329** Contact Plate with scale for DELTA 30

**HCD330** Small contact plate for DELTA 30

**HCD331** Contact plate with scale for DELTA 30

**HCD332** Table charge for DELTA 30

## HEINE® iC1 Dermatoscope

### The digital dermatoscope

Big, bigger, biggest. The high-quality aspherical optical system with up to 40x true magnification offers everything you need in a practice.

The HEINE iC1 is a image capturing device to record clinical and dermatoscopic images for documenting, monitoring and supporting differential diagnosis of melanoma and other skin lesions.

Innovative HEINE LEDHQ illumination combined with precision optics provide high resolution and reflex-free images with an Apple® iPhone® from version 5s upwards or iPod touch® 6th generation\*. The integrated Toggle Function allows you to easily alternate between polarised and non-polarised views.

- Toggle function for switching between polarised and non-polarised illumination mode.
- Free iC1 App
- LED in HEINE Quality – or LED HQ.

Set includes **contact plate with scale**, mobile phone case and plug-in power approved for medical use.

### Contact us for up-to-date mobile cases

**HCD298** USB Cord with Medical approved plug-in power supply

**HCD299** Contact plate with scale

**HCD300** Mobile phone case iC1/7 for Apple iPhone 7

**HCD301** Mobile phone case iC1/6 for Apple iPhone 6/6s

**HCD302** Mobile phone case iC1/65 for Apple iPhone 5/5s/SE

**HCD303** iPod case iC1/T6 for Apple iPod touch 6th generation



**HCD295** Set with iC1/7 for iPhone 7, USB cord & Power supply

**HCD296** Set with iC1/6 for iPhone 6, USB cord & Power supply

**HCD297** Set with iC1/5 for iPhone 5/5s/SE, USB cord & Power supply

## HEINE EN 200-1 Wall Transformer with DELTA 20 T Dermatoscope

### EN 200-1 Wall Transformer

- A number of Heine instrument heads can be combined with the EN 200-1's handle.
- Meets the current standard IEC 60601-1.
- Built-in theft protection due to the integrated locking screw.
- Excellent energy efficiency: Instruments turn on and off automatically, when they are removed and replaced, and after 15 minutes of non-usage. When the instrument is taken off, the most recently selected brightness level is enabled. This saves time and power.
- Large operating radius - spiral cord with length up to 3.50m.

### DELTA 20 T Dermatoscope

- Toggle function for switching between polarised and non-polarised illumination mode.
- Hi-res images via high-quality achromatic optical system.
- 10 to 16 x magnification is achieved with the focusing system.
- Glare-free and reflection-free view thanks to polarisation, even without immersion fluid.
- Individual focusing, range of correction approx. -6 to +6 dpt.
- Digital documentation: using the HEINE SLR photo adaptor, the DELTA 20 T can be connected to the SLR cameras of major brands without any issues.

**HCD333** Single Unit with one handle – long USB cord and E4-USB power supply, incl. DELTA20T Dermatoscope Head with contact plate 23mm with scale, dermatoscope compendium



## HEINE® DELTA 20 T Dermatoscope

The highest quality images and diagnostic flexibility.

Offers unrivalled precision optics and the functionality to toggle between polarised and non-polarised illumination. No time consuming exchange of contact plates is necessary.

- Crystal clear, high-resolution images thanks to the high-quality achromatic optical system. The focusing system delivers 10x–16x magnification for a detailed view of even the smallest structures.
- Toggle function for switching between polarised and non-polarised illumination mode. With the press of a button. No exchange of contact plates necessary. The additional diagnostic function allows detection of 'blink signs' when viewing crystalline structures and milia.
- Glare-free and reflection-free view thanks to polarisation, even without immersion fluid. For fast and flexible work.
- With just one hand: individual focusing, range of correction approximately -6 to +6 dpt.
- Also capable of digital documentation: using the HEINE digital camera lens system, the dermatoscope can be connected to the SLR cameras of major brands without any issues. Specially developed photo adaptor lenses combine the camera and DELTA 20 T to create an unbeatable pair.



**HCD312** DELTA 20 T with contact plate with scale, BETA4 USB recharge handle with USB cord & power supply

**HCD313** DELTA 20 T with contact plate with scale and BETA 4 NT recharge handle

**HCD314** 2x DELTA 20 T with contact plate with scale, 2x BETA 4 NT recharge handle and NT4 table charger

## Dermlite DL1 Basic

A simple-to-use system that enables patients to monitor moles and skin lesions at home and then send the high quality images to medical professionals for review.

A development of the proven Dermlite DL1 for smartphones, enables patients to capture crystal-clear, polarised dermoscopic images of both pigmented and non-pigmented skin lesions.

- Polarised spacer and glass faceplate
- Standard USB cable for charging
- Mobile device adapter of customer choice
- 10x Magnification with a 15mm Viewing Area
- 4x Bright White LEDs
- Lithium-Polymer Battery with 2 Hours Charging Time
- **Free 'Dermlite Connection Kit' please specify when ordering**
- **Dimensions:** 30mm x 25mm x 90mm / **Weight:** 100g

Full range of mobile connection kits listed online, these are available for most smartphone models.



**HCD263** Dermlite DL1 Basic



**HCD253** Dermlite DL1

## Dermlite DL1

The smallest dermatoscope in the world. It has fantastically crisp and bright optics and is about the same size as a stick of gum!

The DL1 can be used with or without fluid and can even be attached to an iPhone to allow the user to record images of the lesions presented to them.

**Pack consists of:**

- Dermlite DL1
- **Includes one free 'Dermlite Connection Kit' please specify for which iPhone model when ordering**
- 28mm camera attachment for cradle
- Contact spacer polarised
- Contact spacer non polarised
- Non contact cross polarisation adapter
- USB charging cable and Lanyard

Full range of mobile connection kits listed online, these are available for most smartphone models.



## DermLite DL-100

Simple, quick & precise lesion diagnosis for earlier detection of skin cancer - without the use of oil. By incorporating diode lighting technology for bright-white, natural illumination, DL-100 allows for clear and deep view into pigmented lesions for detection of melanoma and dysplastic naevi in seconds.

- Compact portable design requiring no skin contact
- Diode lighting from 8 LEDs with lithium battery for 1200 exams
- 10X Hastings Triplet lens with glare-free cross-polarisation
- Oil-free 'Dry' epilluminescence

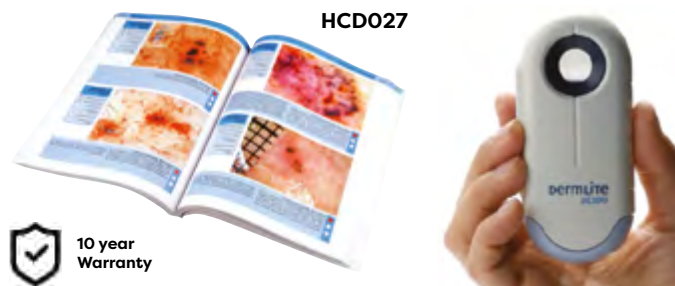

**HCD021** DE-L-100 DermLite Basic

**HCD021.1** Belt Pouch Case for DermLite Basic/Carbon

**HCD027** Dermoscopy - Training Book

## DermLite Carbon

Provides instant toggle control over lesion visualization from the superficial structures to the deeper pigmentation, by separately activating two groups of light-emitting diodes (LED), each with distinct polarisation: The first group of eight LEDs produces cross-polarised light, ideal for visualizing deep structures, whereas the second set of eight LEDs is linearly polarised, giving you a clear rendition of the skin surface.

- Carbon's 16 LEDs are powered by the same highly efficient, long-lasting lithium battery that powers the original DermLite
- Carbon is supplied with one 2CR5 DermLite lithium battery, and one belt pouch



**HCD21.1** DermLite Carbon

## DermLite DL200 HR

Adopts the optical system from DL2 in an easy-clean body and integrates a super-quick, retractable spacer mechanism with precise focusing, IceCap™ (infection control caps) compatibility.

- Ultra bright and polarised only
- Compact, ergonomic design
- Mobile-device compatible
- 20% more life than its predecessor
- Four-level charge indicator
- Contact and non-contact dermoscopy
- Faceplate width 10mm
- **Full range of mobile connection kits listed online, these are available for most smartphone models.**



**HCD210** DermLite DL200 High Resolution

## DermLite DL200 Hybrid

Offers all the functionality of the DL200 but has been developed to also offer the additional benefits of having polarised & non-polarised lighting options in a single device.

- Toggle between polarised and non-polarised
- Mobile-device compatible
- 20% more life than its predecessor
- Four-level charge indicator
- Contact and non-contact dermoscopy
- Faceplate width 10mm

**Full range of mobile connection kits listed online, these are available for most smartphone models.**

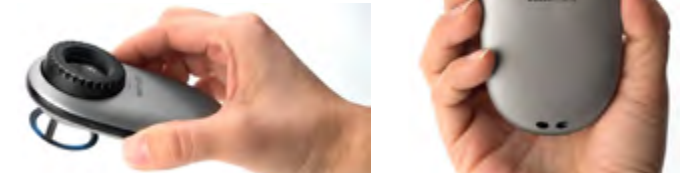

**HCD284** DermLite DL200 Hybrid

## DermLite Lumio

Ideal for skin exams where an in-depth, glare-free image of the skin is essential. With its 75 mm lens offering a magnification of 2x, the power of 40 bright-white LEDs (light emitting diodes) & cross-polarisation

- Includes 4x AA batteries and one protective neoprene pouch.
- Permanent cross-polarisation
- 40 LEDs
- 75 mm 2x lens



**HCD212** DermLite Lumio

## DermLite Lumio UV

A modern reincarnation of a Woods lamp. With its 75 mm lens offering a magnification of 2x, the power of 40 UV LEDs (light emitting diodes) Lumio UV is a great tool for many examinations.

- Includes 4x AA batteries and one protective neoprene pouch.
- Permanent cross-polarisation
- 40 UV LEDs
- 75 mm 2x lens



**HCD274** DermLite Lumio UV

## Dermlite DL3N

For optimum ease of use, a quick tap on its power button toggles between polarisation modes while the optional Pigment Boost mode produces a warmer illumination. The convenient Dermlite DL3N retractable faceplate spacer design and focusing mechanism enables you to quickly switch between non-contact and skin contact modalities.

The spacer comes with a glass faceplate with 10mm markings and, due to its fully enclosed design, contaminants as well as undesirable ambient lighting no longer affect your image. An optional eyepiece is included. Simply attach your digital camera, smartphone or iPad, extend the spacer, and start taking sharp, glare-free images quickly and easily.

This state-of-the-art device will notify you when its long-lasting battery needs to charge: Once the charge level drops below 25%, the '3' on the top of device changes from green to orange.

**Dimensions:** 3.6 x 5.3 x 14.4cm / **Weight:** 180g

**Supplied with** charging base, eyepiece, case, spacer & lanyard

**Full range of mobile connection kits listed online, these are available for most smartphone models.**

HCD264 Dermlite DL3N



## Dermlite DL4

Designed to be more refined in every detail. An amazingly smooth, ergonomically optimised, all aluminum design that comfortably molds to your hand, with phenomenal versatility, the largest optics and instant on/off control right at your fingertips.

### Larger lens, smaller package

Built upon the DL3's proven polarised & non-polarised lighting and solid battery life, DL4 now offers two brightness levels, a larger field of view, enhanced imaging of deeper pigmentation with two levels of color spectrum control (PigmentBoost Plus).

### See deeper. Even into the battery

Dermlite DL4's high-powered LEDs and rechargeable battery produce light in an extremely energy-efficient way. And, in order to know when you run out of battery, DL4 now has a more granular four-level charge indicator. If you need to recharge, you can do so from any USB port using the standard Micro USB to USB cable included with each DL4.

### Infection Control? – You're covered

Along with the growing need for dermoscopy, infection control is an important aspect of providing care. With its Infection Control and Epidemiology system IceCap™. Disposable snap-on IceCaps attach to the spacer, reducing the risk of cross-contamination.

### Magnetically smart

DL4 uses magnetic connectivity to achieve ground-breaking convenience. Not only are both faceplate & eyepiece magnetically attached, your smart-devices attach magnetically, allow clinical and dermoscopic photos quicker than ever before.

### Smooth. Speedy. Precise

A new DL4 retractable glass faceplate design allows you to go between non-contact & contact modalities smoother than ever and lets you precisely focus your image while in skin contact.

HCD273 Dermlite DL4

HCD285 Ice Caps for use with Dermlite DL4 (Pack of 25)

- 30mm viewing area
- 10x magnification
- Cross-polarised and non-polarised modes
- High-powered white LEDs
- Pigment Boost & Pigment Boost Plus
- IceCap Infection Control (5 samples included)

**Full range of mobile connection kits listed online, these are available for most smartphone models.**



## DermLite Lumio S

Lumio S opens a new era in skin diagnostics. With its superb 40 mm lens producing 4x magnification, this device hits the spot between large-area, low magnification viewers and the close quarters of a dermoscopic image.

The minimalist design of Lumio S is functional and cool. A clean, elegant exterior is much easier to keep clean between patients, its ergonomic soft-touch body provides a comfortable, secure grip, and its genuine Corning GorillaGlass® top and bottom surfaces are extremely strong and scratch-resistant. Charged from any USB power source using the USB cable (incl.)



HCD288 DermLite Lumio S

## Dermlite Foto II Pro

Activate the unit by simply pushing the power button, and a ring of bright-white LEDs powered by two extremely powerful, on-board lithium-polymer batteries illuminate a field of view that can range from as small as 9 mm for typical lesions to 20 mm in diameter for larger sites, depending on the camera used.

Tap the button to toggle between polarised and non-polarised modes or simply attach the included flash cable to do this automatically after each image.

**The Dermlite Foto II Pro is supplied with:**

- Camera Adapter Ring & Charger
- Flash Cable



HCD286 Dermlite Foto II Pro

## Riester ri-derma Dermatoscope

Today skin cancer is a commonly occurring disease, which can often be diagnosed and treated at an early stage. The ri-derma® dermatoscope offers physicians and specialists a reliable method of dermoscopic screening and early identification of malignant melanomas.

Proven epiluminescence microscopy allows melanocytic and non-melanocytic structures to be distinguished and accurately observe changes in skin pigmentation.

- 10x magnification of the structure of the skin with focussing, achromatic lens.
- Two different skin-friendly and sterilisable contact plates: with scale from 0-10mm for exact measurement of pigmented skin lesions, without scale
- LED bulbs now have approx. 100,000 hours service life.
- Comes in a protective hard case
- Stable casing of black chrome-plated metal, dust-proof Practical eyeglass protection
- Bayonet fitting for quick and secure attachment of the instrument head to the handle



HCD009 2.5V LED Dermatoscope (requires 2x C battery, not rechargeable)

HCD009.1 3.5V LED Dermatoscope (Rechargeable, Requires charger)

HOP1419 Riester Recharger for Dermatoscope (phone type with battery)

## Grafton U.V. Woods Lamp

- Comes with white tube
- Lens with a focal length of 20cm
- For a variety of applications: corneal scratches, blocked tear ducts, fungal infections
- Hand-held ultraviolet lamp for detection of skin disorders
- Incorporates standard torch and 130mm UV tube
- Powered by 4 x AA batteries Incl.



HCD011 U.V. Woods Lamp

## HemoCue® Hb 201+ System

### The Standard for Uncompromising Accuracy

Providing lab accuracy and ease of use, the HemoCue® Hb 201+ System has become a standard in Hb point-of-care testing. Healthcare providers around the world rely on the immediate results so they can make the right decisions when they need them most – right at the point of care.

With dedicated support and service, as well as unmatched training and education based on over 35 years of experience, you can count on HemoCue for the right solutions for all your needs.

**BCH561** HemoCue 201+ Haemoglobin Analyser

**BCH568** HemoCue Hb/Plasma Low/Glucose cleaner - 5pk

**BCH569** Martel Printer Universal Kit for WBC Total or 201+

**BCH565** Quality Control \*HemoTrol Low 2x1 ml

**BCH566** Quality Control \*HemoTrol Normal 2x1 ml

**BCH567** Quality Control \*HemoTrol High 2x1 ml

### Have Confidence in Your Answers at the Point of Care

- Precise factory calibration against the ICSH reference method
- Microcuvette technology with excellent lot-to-lot reproducibility
- Date and time storage for up to 600 results
- Blood-based liquid controls available

### Get Easy Access to Lab-Quality Accuracy

- Capillary, venous or arterial whole blood sample
- Brief training with virtually no maintenance
- Link result with patient ID for medical record integration
- Printer interface



**BCH577** Annual Return to Base Service Contract

**BCH570** Martel Printer Cable for HemoCue 201+

**BCH571** Small Carrying Case for one 201 system

**BCH562** Haemoglobin 201+ Microvettes - 4 x 25

**BCH563** Haemoglobin 201+ Microvettes - Individually Wrapped 4 x 25

## HemoCue® WBC DIFF System

### The Innovative Difference for Faster Care

With groundbreaking technology, the HemoCue® WBC DIFF System makes it possible to get not only lab-accurate white blood cell counts but also five-part differentials at the point of care. In just five minutes, you have accurate counts for neutrophils, lymphocytes, monocytes, eosinophils and basophils.

Fitting seamlessly into a variety of clinical applications and even remote field clinics, the benefits are clear. Immediate WBC DIFF counts can mean the difference between waiting and taking action at the point of care – helping you move from assessment to treatment within minutes rather than hours or days.

**BCH559** HemoCue WBC DIFF Analyser

**BCH585** WBC DIFF Annual Return to Base Service Contract

**BCH560** WBC DIFF Microcuvettes - 2 x 25

**BCH584** HemoCue WBC and WBC DIFF cleaner - 5pc

**BCH569** Martel Printer Universal Kit for WBC Total or 201+

### Answers Right When You Need Them

- Lab-accurate results in minutes
- Faster treatment decisions and streamlined workflow
- Easy to use by non-laboratory personnel after a brief training
- Capillary or venous samples

### Accuracy for Confident Decisions

- Factory calibration with no further calibration needed
- Unique software for internal QC
- Automatic warning for unidentified cells



**BCH595** Quality Control \*WBC DIFF Control Kit (3 x 2ml) - 2 Month

**BCH594** Quality Control \*WBC DIFF Control Kit (3 x 2ml) - 1 Month

**BCH586** Opticon USB Barcode scanner

**BCH570** Martel Printer Cable for HemoCue 201+

## HemoCue® WBC System

### From Assessment to Treatment Faster

Based on HemoCue's proven, reliable microcuvette technology, the HemoCue® WBC System brings you the unique benefit of determining total white blood cell counts right at the point of care. In just three minutes, you have results with the same precision and accuracy as those from a central laboratory.

Fitting seamlessly into a variety of clinical applications and even remote field clinics, the benefits are clear. Immediate WBC counts can mean the difference between waiting and taking action at the point of care – helping you move from assessment to treatment within minutes rather than hours or days.

**BCH559.1** HemoCue WBC Total Analyser

**BCH583** Quality Control \*WBC Solution Lvl 1/2/3 (NOT DIFF) (2x1ml of each)

**BCH577** WBC Total Annual Return to Base Service Contract

**BCH569** Martel Printer Universal Kit for WBC Total or 201+

### Answers Right When You Need Them

- Lab-accurate results in minutes
- Faster treatment decisions and streamlined workflow
- Easy to use by non-laboratory personnel after a brief training
- Capillary or venous samples

### Accuracy for Confident Decisions

- Factory calibration with no further calibration needed
- Unique software for internal QC
- Blood-based liquid controls available



**BCH560.1** WBC Microcuvettes - 4 x 40

**BCH584** HemoCue WBC and WBC DIFF cleaner - 5pc

**BCH570** Martel Printer Cable for HemoCue 201+

## HemoCue® Glucose 201+ System

### Accurate Answers With Full Confidence

The HemoCue® Glucose 201+ System puts lab-quality answers in health professionals' hands when they're needed most – at the point of care. Not only does the unique microcuvette technology enable accuracy in just three simple steps, but it also reduces contamination risks.

### Enables Right Decisions at the Point of Care

- For screening, monitoring and aid in diagnosis of diabetes mellitus
- Precise monitoring for better glycemic control
- Reduced risk of missed hypoglycemia in newborns

### Reduces Margins of Error and Risks of Infection

- Microcuvette technology means no need to bring analyzer near patients, reducing the risk of spreading infection
- Individually wrapped microcuvettes to minimize contamination and maximize shelf-life
- Minimal lot-to-lot variation
- Factory calibrated analyzers, means no need to recalibrate

### Offers Convenience and Flexibility

- Portable and battery-operated system ideal for mobile settings



BCH551	201+ Glucose Analyser
BCH577	Annual Return to Base Service Contract
BCH578	Quality Control *GlucoTrol NG Level 1
BCH579	Quality Control *GlucoTrol NG Level 2
BCH580	Quality Control *GlucoTrol NG Level 3
BCH578.1	Quality Control *GlucoTrol NG Level 4
BCH582	Quality Control *GlucoTrol NG Level 5

BCH569	Martel Printer Universal Kit for WBC Total or 201+
BCH570	Martel Printer Cable for HemoCue 201+
BCH571	Small Carrying Case for one 201 system
BCH568	HemoCue Hb/Plasma Low/Glucose cleaner - 5pk
BCH552	*Glucose 201+ Microcuvettes - 4 x 25
BCH553	*Glucose 201+ Microcuvettes - Indiv. Wrapped 4 x 25

## HemoCue® Hb 801 System

### Innovation at its best from the pioneers in Hb testing

With the introduction of HemoCue® Hb 801 System we are taking the Hb point-of-care testing to a new level. The system is designed with your needs in mind, maintaining the robustness and quality you expect from HemoCue products. It provides ease of use and enables work flow efficiency with connectivity options delivering fast result at the time of care.

HemoCue® Hb 801 System is optimized for hemoglobin testing in hospital\*, primary care and public health settings. The system provides quick, easy access to lab-quality results without compromising accuracy, even in demanding climates with high temperatures and humidity.

### Maximize Time with Your Patients

- Immediate result in less than 1 second
- Work everywhere with flexible power supply options
- Easy to clean - less down time

### Experience Daily Operational Efficiency

- Large display and symbols allow you to quickly monitor workflow and result
- "Let-go-grip" - no need to keep holding the microcuvette down during measurement
- Vendor-neutral connectivity offers flexibility for e.g. data transfer

### Trust Your Results at the Point of Care

- Factory calibrated against the ICSH recommended reference method. No further calibration needed
- Robust design and accurate testing within a wide range of temperatures and humidity
- Built in self-test



BCH004	HemoCue Haemoglobin 801 Analyser g/L
BCH004.1	Haemoglobin 801 Microcuvettes 4 vials of 50
BCH004.2	Quality Control *Haemoglobin 801 HemoTrol Duo Low

\* Only for markets where EU IVDD CE mark is applicable

BCH004.3	Quality Control *Haemoglobin 801 HemoTrol Duo Normal
BCH004.4	Quality Control *Haemoglobin 801 HemoTrol Duo High

## HemoCue® HbA1c 501 System

### Designed to Work for How You Work

A fully automated point of care system where every element – from its size to the storing and handling of cartridges – is thought through to be ideally suited for how you work.

Tested according to HemoCue principles, and with automatic checks and calibrations built into the system, you can count on getting the right answer at the right time – at the point of care.

So you won't miss a beat in caring for your patients.



**BCH592** Martel Printer Cable for HemoCue HbA1c 501

**BCH591** HemoCue HbA1c 501 Barcode Scanner

**BCH593** Analyser Annual Return to Base Service

### Makes Your Whole Process Easier and More Efficient

- Only a few simple steps with clear instructions on screen
- All-in-one, individually packaged cartridge kits
- Convenient room-temperature storage up to 18 months

### Ensures You'll Never Have to Doubt an Answer at the Point of Care

- Unaffected by the presence of most common Hb variants\*
- IFCC and NGSP certified
- Precise, fixed calibration by factory

### Provides a Reliable Workflow for Excellent Patient Care

- Automatic reading of calibration data for each test cartridge lot
- Barcode reader for patient and operator ID available
- Connectable

\* HbF > 20% may cause unreliable results

**BCH554** HbA1c 501 Analyser

**BCH569** Martel Printer Universal Kit for HbA1c 501

**BCH555** HbA1c 501 Test Cartridge packs of 10

**BCH556** HbA1c 501 Monthly Check Cartridge packs of 6

**BCH557** HbA1c 501 Daily Check Cartridge Single packed



**BCH400** CardioChek PA Blood Analyser

**BCH401** Glucose strips - 25pk (Requires 15µL pipette)

**BCH402** Cholesterol strips - 25pk (Requires 15µL pipette)

**BCH404** HDL strips - 25pk (Requires 15µL pipette)

**BCH405** Triglyceride strips - 25pk (Requires 15µL pipette)

**BCH407** Cholesterol & Glucose duo - 25pk (Requires 30µL pipette)

**BCH408** Cholesterol & HDL duo - 25pk (Requires 30µL pipette)

**BCH409** Cholesterol, HDL & Glucose triple - 15pk (Requires 40µL pipette)

**BCH419** CC Printer Label Roll (5 x 160 Label roll)

## CardioChek PA Blood Analyser

The CardioChek Professional Analyser (PA) is an easy-to-use point-of-care system ideal for multiple clinical settings. Approved in 2009 by the NHS Centre for Evidence-based Purchasing, it is now extensively used in the NHS Healthchecks program. With over 8000 devices in use within the UK, it is our most popular and best-selling device!

Capable of measuring a number of analytes including the total cholesterol, high density lipid (HDL) cholesterol, triglycerides, and glucose (mmol/L). In addition, the CardioChek® PA system can also calculate cholesterol ratios. Only a small blood sample (15 – 40 µL) is required. Results are delivered in less than 2 minutes so you can make your recommendations to your patient there and then saving you and your patient's time!

- **Innovative:** Portable hand-held device
- **Fast:** Results in one to two minutes
- **Flexible:** Suitable for multiple clinical applications
- **Accurate:** CE marked / FDA cleared / CLIA waived
- **Convenient:** Test at point-of-care, no fasting, no refrigeration
- **Cost-effective:** No pricey lab analysis or consultation delay
- **Fully automated:** Simply pipette a single sample to test strip
- **Memory Log:** Stores up to 200 results – date/time stamped

**BCH411** Lipid Panel: Cholesterol, HDL, LDL & Triglycerides - 15pk (Requires 40µL pipette)

**BCH412** Pipette 15 µL - 25pk

**BCH413** Pipette 30 µL - 25pk

**BCH414** Pipette 40µL - 16pk

**BCH415** Multichemistry Control Sol

**BCH416** HDL Control Sol

**BCH417** CardioChek PRINTER

## QBC® Haematology Test Kits



### QBC AccuTubes

- AccuTubes can be used for capillary samples, as well as venous blood samples
- Packaged with a ventilated stopper inserted into the tube and a soft grip float holder for easy insertion of the plastic float
- For use with the QBC Autoread™ Plus

### QBC Capillary Tubes

- These tubes can be used with blood samples taken from a finger or heel stick
- For use with QBC Autoread™ Plus

**BCH532** AccuTubes - 100pk

**BCH538** AccuTube Pipetter Spacer

**BCH535** Capillary Tubes - 100pk

**BCH536** Capillary Tubes - 1000pk (5x200 tests)



### QBC Venous Tubes

- These tubes can be used with the pipetter to draw samples from venous tube
- For use with the QBC Autoread™ Plus

### QBC Star Tubes

- Can be used for venous or capillary blood
- Plastic float protecting the glass capillary type tube
- For use with QBC STAR™

**BCH533** Venous Tubes - 100pk

**BCH534** Venous Tubes - 1000pk (5x200 tests)

**BCH518** QBC STAR Tubes - 100pk

**BCH537** Pipetter r/p

**BCH539** Pipetter Barrel



## Roche Cobas h 232

### Designed for rapid diagnosis of DVT, Heart Failure and Atrial Fibrillation

- Results available in 8–12 minutes
- Rapid, on-the-spot decision support for treatment, referral, or discharge of cardiovascular patients
- Portable device which is suitable for use in the GP's surgery, one stop clinics or community hospitals
- Ease of use - insert strip, apply sample, read result
- No maintenance, Easy to clean & on board QC built in
- Quality assurance via patient ID and QC operator lock-out
- Results transmitted via IR to printer or Base Unit

**BCH140.3** Cardiac M 20 tests

**BCH140.4** Cardiac Control Troponin-T

**BCH140.7** Cardiac D-Dimer Control

**BCH140.8** Cardiac Control proBNP

**BCH140** Cobas h 232 Kit

**BCH141** cobas Cardiac D-Dimer (10 tests)

**BCH142** cobas Cardiac ProBNP (10 tests)

**BCH143** cobas Cardiac T Quantitative. (10 tests)

Test Strip	Parameter	Reaction Time	Measuring Range	Clinical Utility
Roche Cardiac D-Dimer	D-Dimer	8 minutes	0.1–4.0 µg/mL	Exclusion of deep vein thrombosis and pulmonary embolism
Roche Cardiac ProBNP	NT-proBNP	12 minutes	60–9000 pg/mL	Aid in diagnosis of patients with suspected heart failure, in monitoring patients with compensated left ventricular dysfunction and in risk stratification of patients with acute coronary syndroms
Roche Cardiac T Quantitative	Troponin T	12 minutes	50 - 2000 ng/l Quantitative range: (100 - 2000 ng/l)	Diagnosis of acute coronary syndrome and myocardial infarction
Roche Cardiac CK-MB	CK-MB	12 minutes	1.0 - 40 ng/ml	Diagnosis of acute coronary syndrome and myocardial infarction, assessment of re-farction
Triangular Bandage	Myoglobin	8 minutes	30 - 700 ng/ml	Early marker of myocardial damage to assist in diagnosis of acute coronary syndrome and myocardial infarction.

## Roche CoaguChek Pro II

Used for the determination of PT by healthcare professionals in a Point-of-care environment. In addition to INR monitoring, testing PT in critical care situations helps to:

- Assess coagulation status in bleeding patients or for those taking vitamin K antagonists in A&E
- Assess vitamin K deficiency, monitor bleeding risk, manage hemostasis and transfusion therapy in the operating room
- Assess vitamin K status and/or vitamin K deficiency in the ICU
- Built in Wifi - results can be automatically shared among practitioners and patients for convenient access and delivery
- No need to dock meter to transmit results
- Integrated 1d and 2d barcode scanner to capture Operator and Patient IDs
- The enhanced features of CoaguChek Pro II are simple to use, especially if you have used CoaguChek® XS Pro or XS Plus
- Intuitive user interface makes it easy to use and easy to train
- Decreased turnaround time with cost savings



<b>BCH135</b>	CoaguChek Pro II Monitor
<b>BCH135.1</b>	Handheld Base Unit for CoaguChek Pro II
<b>BCH135.2</b>	CoaguChek PT controls (L1&L2) - 2 x 4
<b>BCH135.3</b>	CoaguChek PT test strips - 1 x 48
<b>BCH135.4</b>	Safe-T-Pro Plus Single Use - 200pk

## Roche Urisys 1100 Urine Analyser

**Only compatible with Roche Combur 10 UX Strips.** Inbuilt quality assurance functions, provides standardised results & virtually eliminates possible sources of visual evaluation errors.

The Urisys 1100 Urine Analyser is extremely easy to use. Simply place the test strip on the test strip tray. Incubation, evaluation and printout occur automatically, quickly and quietly. Positive results are flagged, making them immediately recognisable.

- State-of-the-Art Urinalysis For fast, standardized results quickly
- Throughput up to 50 tests per hour
- 100-result memory
- Fast, quiet output of results to integrated thermal printer
- Easy connection to computer systems



<b>BCH278</b>	Roche Urisys 1100 Urine Analyser
<b>BCH081.1</b>	Roche Combur 10 UX Test Strips - Box of 100

## Roche Accutrend Plus System

The Accutrend Plus system is a flexible, hand-held point-of-care device for the key parameters used to detect cardiovascular disease: Total cholesterol and Triglycerides. The meter is suitable for professional use as well as for self-testing.

- Simple determination of cholesterol & triglycerides using capillary blood
- Great precision and accuracy across measuring range
- Positive control strip and parameter recognition are used for calibration
- Test strips stored at room temp.
- Can store up to 100 different results with date, time and flags



<b>BCH0531</b>	Roche Accutrend Plus Meter Only
<b>BCH054</b>	Cholesterol Strips - 25pk
<b>BCH145</b>	Triglyceride Strips - 25pk
<b>BCH147</b>	Cholesterol Control Solution CH1 - 1 x 1.5ml
<b>BCH148</b>	Glucose Control Solution - 2 x 4ml
<b>BCH149</b>	Lactate Control - 1 x 1.5ml

## Roche Combur-Test Urinalysis Strips

Code	Parameter	B	L	U	Br	N	Sg	G	P	K	pH
<b>BCH084</b>	<b>Combur 3</b>							✓	✓		✓
<b>BCH076</b>	<b>Combur 4</b>					✓		✓	✓		✓
<b>BCH082</b>	<b>Combur 5</b>	✓						✓	✓	✓	✓
<b>BCH079</b>	<b>Combur 7</b>	✓	✓			✓		✓	✓	✓	✓
<b>BCH080/1</b>	<b>Combur 9</b>	✓	✓	✓	✓	✓		✓	✓	✓	✓
<b>BCH081</b>	<b>Combur 10</b>	✓	✓	✓	✓	✓	✓	✓	✓	✓	✓

- B - Blood
- L - Leukocytes
- U - Urobilinogen
- Br - Bilirubin
- N - Nitrite
- Sg - Specific Gravity
- G - Glucose
- P - Protein
- K - Ketones
- pH - Potential of Hydrogen



- All test zones read in one to two minutes
- Store the test strips at a temperature between +2° and 30° C
- Clear & convenient reading - the precise, vertical colour scale on the vial label, exactly match the reaction colours on the strip pads
- Long strip handle contributes to safety
- Protected against the interference of Vitamin C by iodate.



<b>BCH084</b>	Combur-3 - 50pk
<b>BCH076</b>	Combur-4 N - 50pk
<b>BCH082</b>	Combur-5 - 50pk
<b>BCH079</b>	Combur-7 - 100pk
<b>BCH080</b>	Combur-9 - 100pk
<b>BCH080.1</b>	Combur-9 - 50pk
<b>BCH081</b>	Combur-10 - 100pk



## 3 DAYS PUNCTURE FREE

After the application of your **i-Port Advance** you can easily administer multiple injections!

Over the course of 3 days, you will take up to 15 injections. With **i-Port Advance**, it's only a single application.



LESS PAIN<sup>1</sup>

LESS ANXIETY<sup>1</sup>

IMPROVES QUALITY OF LIFE<sup>2</sup>



DO YOU ALTER ACTIVITIES TO AVOID INJECTIONS?

**43%**  
ALTER EATING HABITS<sup>3</sup>



**19%**  
ALTER PHYSICAL ACTIVITY<sup>3</sup>



**15%**  
ALTER SOCIAL EVENTS<sup>3</sup>



WITH **i-PORT ADVANCE** YOU ONLY NEED TO INJECT ONCE EVERY 3 DAYS VERSUS EVERY DAY WITH STANDARD INJECTIONS

Continue your current diabetes treatment with one **i-Port Advance**<sup>3</sup>

**BOLUS**  
e.g., insulin lispro, insulin aspart



**BASAL**  
e.g., insulin glargine, insulin detemir

**i-Port Advance** can be used for Basal and Bolus Doses



**100%**  
REPORTED THAT **i-PORT ADVANCE** HELPED THEM TO DECREASE ANXIETY<sup>4</sup>

**99%**  
OF PATIENTS REPORTED THAT **i-PORT ADVANCE** WAS BENEFICIAL<sup>4</sup>

UC201705345 EN

1. Hanas R, Adolfsson P, Elfvin-Akesson K et al. Indwelling catheters used from the onset of diabetes decrease injection pain and pre-injection anxiety. *J Pediatr*. 2002;140(3):315-320

2. Rabbone I, Bobbio A, Di Gianni V, Sacchetti C, Cerutti F. Intensive insulin therapy in preschool diabetic children from multiple daily injections to continuous subcutaneous insulin infusion through indwelling catheters. *J Endocrinol Invest*. 2008;3(3):193-195

3. Blevins T, Shwartz SL, Bode B et al. A study assessing an injection port for administration of insulin. *Diabetes Spectr*. 2008;21(3):197-202

4. Riley D, Raup G. Impact of a subcutaneous injection device on improving patient care. *Nurs Manage*. 2010;41(6):49-50

6. Ruben, Peyrot, Kruger, Travis. Barriers to Insulin Injection Therapy: Patient and Health Care Provider Perspectives. *The Diabetes Educator* 2009; 35:1014

## i-Port Advance™

i-Port Advance™ is a discreet injection port that comes with an inserter for patients who use a pen or syringe to administer multiple daily subcutaneous injections. It is suitable for both adults and children.

Each i-Port enables multiple subcutaneous injections for three days (or 75 injections) without having to puncture the skin for each dose of medication. The port can be worn during all normal activities, including exercising, sleeping, and bathing.

Each port is very easily applied. It includes a built-in inserter, which gives you a quick, virtually painless application. Only a soft flexible tube, called a cannula stays under the skin. Once applied, inject your medication through the port instead of your skin (no medication is stored inside the device).

Available in two sizes, and quantities:

- i-Port Advance™ 6mm cannula – MMT-100 (box of 10 or 2)
- i-Port Advance™ 9mm cannula – MMT-101 (box of 10 or 2)



### Get to know i-Port Advance

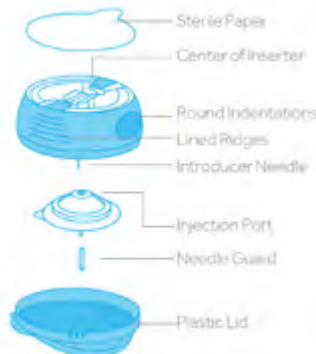

### Where to apply

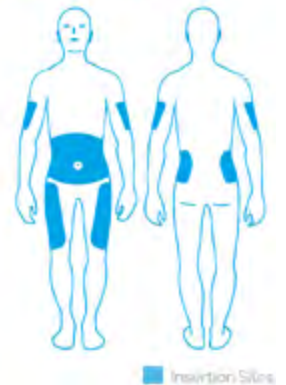

**BCH627** 6mm Cannula (Box of 10)

**BCH628** 9mm Cannula (Box of 10)

**BCH627.2** 6mm Cannula (Box of 2)

**BCH628.1** 9mm Cannula (Box of 2)

## Clinitek Status+™ Urine Analyser

The analyzer automatically checks each test strip for humidity exposure, common sample interferences and strip identification for Siemens test strips. Together, these provide improved clinical information. Enhances confidence in clinical decisions with Auto-Checks performed on every test.

- Detects common sample interferences and provides a comment if detected
- Checks integrity of each test strip for exposure to humidity
- Identifies type of Siemens urine strip automatically
- Printed record avoids transcription errors
- Comprehensive urine test menu including general urinalysis, pregnancy testing, and microalbumin:creatinine ratio



**BCH008.1** Clinitek Status+™ Urine Analyser

**BCH013** Printer Paper - 25pk

**BCH009** Multistix 8 SG - 100pk

**BCH010** Multistix 10 SG - 100pk

**BCH011** Clinitek Microalbumin - 25pk

**BCH035** Multistix GP - 25pk

**BCH121** Clinitest hCG Cassette - 25pk

## DCA Vantage Analyser

The point-of-care diabetes system that gives you the most proven, clinically relevant menu available. Delivering enhanced HbA1C and Microalbumin testing results including A:C Ratio.

- HbA1C & A:C Ratio testing in 6 and 7 minutes, respectively
- Comfortable by requiring a small blood sample (1uL) for HbA1C
- Provides HbA1C patient trend graph
- Proven to provide accurate and precise lab-quality results
- Optional barcode patient data entry to reduce errors
- Onboard printed results eliminating errors and saving time
- Large memory stores up to 4000 records, easily downloadable and transferred to a PC
- Add sample to test cartridge, load, and walk away
- No sample or reagent preparation
- Colour touch screen for menu nav, data entry and data recall
- Minimal maintenance required with automatic reminders



**BCH275** DCA Vantage Analyser

**BCH420** DCA HbA1c Control Kits

**BCH421** DCA HbA1c Claim Kits - Pack of 10

## MULTISTIX Range of Urinalysis Strips

Code	Size	G	Br	K	Sg	B	pH	P	U	N	L	Al	C
BCH035	25	✓		✓	✓	✓	✓	✓		✓	✓		
BCH009	100	✓		✓	✓	✓	✓	✓		✓	✓		
BCH010	100	✓	✓	✓	✓	✓	✓	✓	✓	✓	✓		
BCH036	100	✓	✓	✓	✓	✓	✓	✓	✓				
BCH034	25											✓	✓
BCH041	50	✓						✓					
BCH018	50											✓	
BCH030	50	✓				✓	✓	✓					
BCH011.1	25	✓		✓		✓	✓	✓		✓	✓	✓	✓
BCH011	25											✓	✓



- G - Glucose
- Br - Bilirubin
- K - Ketones
- Sg - Specific Gravity
- B - Blood
- pH - Potential of Hydrogen
- P - Protein
- U - Urobilinogen
- N - Nitrite
- L - Leukocytes
- Al - Albumin
- C - Creatinine

Providing the most appropriate tests for early indication of kidney disease for those with diabetes and estb. kidney disease.

**BCH035** Multistix GP - 25pk

**BCH009** Multistix 8 SG - 100pk

**BCH010** Multistix 10 SG - 100pk

**BCH034** Microalbustix - 25pk

**BCH036** Multistix SG - 100pk

**BCH041** Uristix - 50pk

**BCH018** Albustix - 50pk

**BCH030** Hema-Combistix - 50pk

- Accurate identification of microalbuminuria
- Samples can be obtained randomly, no need for timing
- Estimates of urinary albumin and protein excretion
- Reliable indications of normal or abnormal results



**BCH011.1** Microalbumin 9 - 25pk\*

**BCH011** Clinitek Microalbumin - 25pk\*

\* The above products are for use with CLINITEK Status+ only.

## i-Smart 30 PRO Electrolyte Analyser

**i-Smart 30 PRO Electrolyte Analyser is a fast and Accurate Electrolyte Testing system**

- Fast, accurate analysis (results in 60 seconds)
- Test Na<sup>+</sup>, K<sup>+</sup>, Cl<sup>-</sup>, HCT and iCa<sup>++</sup>
- 60µl sample volume
- 300,000 test data storage
- Large touch screen LCD
- Battery or mains powered as required
- Autocalibration (no user maintenance)
- Cartridge contains electrode and all consumables
- **Dimensions:** 292 x 256 x 177mm
- **Weight:** 5.5kg

### Measured Parameters

- Na<sup>+</sup> 20 ~ 250mmol/L
- K<sup>+</sup> 0.5 ~ 20.0 mmol/L
- Cl<sup>-</sup> 20 ~ 250 mmol/L
- iCa<sup>++</sup> 0.25 ~ 5.00 mmol/L
- HCT 10 ~ 60%



**BCH622** i-Smart 30 PRO Electrolyte Analyser

**BCH623** i-Smart 30 PRO Cartridge - 50 Tests

**BCH624** i-Smart 30 PRO Cartridge - 100 Tests

**BCH631** i-SMART PRO Cartridge - 200 Tests

**BCH632** i-SMART PRO Cartridge - 300 Tests

**BCH633** i-SMART PRO Electrolyte Quality Control

**BCH634** i-SMART Printer Paper - 1 roll

## QBC® Autoread Plus

The QBC® Autoread Plus haematology system separates centrifugation and analysis for faster processing of high volume. The analyser software features four test modes and one mode for various user-defined options and service checks.

- Optical Signature Analysis (OSA) automatically scans the QBC Tube 8 times, eliminating subjective interpretation
- Totally dry procedure needs no user maintenance: no pumps or tubes to clean, no circulating blood, and no user calibration
- Plug in software cartridges
- 7 minutes to perform a CBC test
- Ability to centrifuge 20 tubes at a time
- Sample safety contained at all times and expense saved.
- No inadvertent calibration errors.
- Integration into lab information system.

### Suitable for a wide variety of applications including:

Emergency rooms, Small laboratories, Paediatric applications, POC settings, Remote healthcare centres, GP practices, Cruise ships, Rural settings, Embassies and Outreach clinics



**BCH524** QBC® Autoread Plus Haematology System

**BCH526** QBC® Autoread Analyser Only (CE Marked)

**BCH525** QBC® Centrifuge (CE Marked)

**BCH528** Epson LX-300/FX-880 Black Ribbon

**BCH530** Compatible Printer

## Safe-T-Pro Lancets

Safe and easy to use, designed to help you get the right amount of blood the first time.

For varying patient conditions, such as poor circulation or calloused fingers. Healthcare professionals have the flexibility at the bedside to choose the optimal depth based on the patient condition and blood volume required.

Multiple safety features combined with customised settings make the this lancing device especially advantageous.

- Quick and easy to use
- Prevents cross-contamination
- No Needle Stick Injury
- Single use, safety lancet
- Adjustable disposable lancet
- Silicone coated lancet for virtually pain free testing

**BCH118.1** Uno Lancets - 200pk

**BCH118** Plus Lancets - 200pk

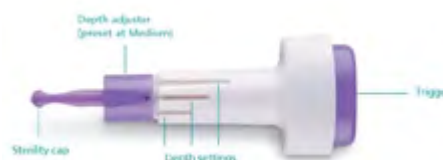

## Digital Fetal Dopplers

Combining the best performance in probe sensitivity, audio clarity and a new visual representation of the fetal heart rate. Colour screen displays provide 'Big Number' views and an innovative 'Graphic FHR' view, enabling intermittent auscultation examinations to be electronically documented.



All Huntleigh Fetal Dopplers include a free **Sonicaid Dilatation Guide**.

These help healthcare staff track how labour is progressing. This chart ranges from 1-10cm

### Sonicaid SR2 Digital Obstetrics Doppler

The Sonicaid SR2, Rate and Graphic FHR display Doppler with a fixed 2 MHz waterproof probe. This high sensitivity handheld digital doppler is intended for general purpose screening of the FHR at all stages of pregnancy from as early as 8-10 weeks, right through to labour.

- **Large FHR modes:** Enhanced FHR screening with colour high visibility backlit screen, 'BIG' numbers and 'Graphic FHR' display view
- **Improved Audio:** Dynamic Digital Noise Reduction & gel filter
- **Improved Performance:** Special High performance probes
- **Rechargeable:** Reduced running costs

#### Optional Extra:

Trace and sound storage, store and playback trace & audio data

**HDO085** Sonicaid SR2 with Alkaline batteries

**HDO086** Sonicaid SR2 with Rechargeable Batteries & Charger



### Sonicaid SR3 Digital Obstetrics Doppler

The Sonicaid SR3, Rate and Graphic FHR display Doppler with a fixed 3 MHz waterproof probe. Selected as the preferred model by many clinicians for early pregnancy use as well as general purpose screening gestation.

- **Large FHR modes:** Enhanced FHR screening with colour high visibility backlit screen, 'BIG' numbers and 'Graphic FHR' display view
- **Improved Audio:** Dynamic Digital Noise Reduction & gel filter
- **Improved Performance:** Special High performance probes
- **Rechargeable:** Reduced running costs

#### Optional Extra:

Trace and sound storage, store and playback trace & audio data

**HDO087** Sonicaid SR3 with Alkaline Batteries

**HDO088** Sonicaid SR3 with Rechargeable Batteries & Charger

### Sonicaid SRX Digital Obstetrics Doppler

The Sonicaid SRX, Rate and Graphic FHR display Doppler with choice of interchangeable non-waterproof 2 MHz or 3 MHz probes. Compatible with all Dopplex vascular XS probes for audio only screening or arteries and veins.

- **Large FHR modes:** Enhanced FHR screening with colour high visibility backlit screen, 'BIG' numbers and 'Graphic FHR' display view
- **Improved Audio:** Dynamic Digital Noise Reduction & gel filter
- **Improved Performance:** Special High performance probes
- **Rechargeable:** Reduced running costs

#### Optional Extra:

Trace and sound storage, store and playback trace & audio data

**HDO089** Sonicaid SRX with Alkaline Batteries

**HDO090** Sonicaid SRX with Rechargeable Batteries & Charger

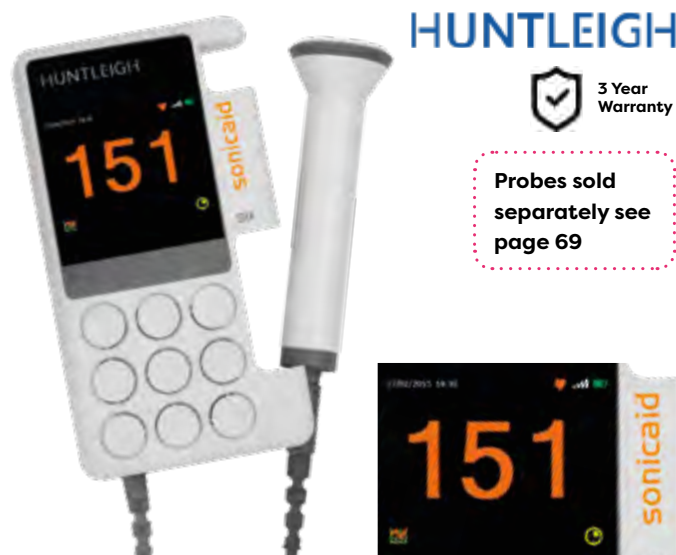

## Sonicaid D920 - Audio Doppler Only

The Audio Doppler provides the highest quality fetal heart sounds, offering reassurance to clinician and parent. 2MHz high sensitivity waterproof probe, with protective rubber bumper and easy to clean gland.

- Provides clear audio only sounds of FHR
- Fixed waterproof 2MHz probe attached
- Low Battery indicator
- Large carry bag Included
- Gel Included

### HUNTLEIGH



5 Year  
Warranty



**HD0015** D920 Audio Doppler Fixed Probe

## Sonicaid D930 - Audio Doppler Only

The D930, with its high sensitivity probe and excellent audio quality, ensures easy and reliable detection throughout pregnancy. The preferred model for many clinicians for early pregnancy use as well as general purpose screening gestation.

- Clear audio sounds of FHR
- Waterproof probes are suitable for water birth use
- Doppler is supplied with large carry bag & gel
- High sensitivity probes for improved ease of use
- Easy clean probe for improved infection control
- Low Battery indicator

### HUNTLEIGH



5 Year  
Warranty



**HD0091** Sonicaid D930

## Digital Vascular Dopplers

Our bi-directional waveform is uniquely generated from the digital Doppler spectrum, providing the clinician objective evidence to assist in the diagnosis of vascular disease that other Dopplers may find difficult or impossible to achieve.

### HUNTLEIGH

The DMX algorithms optimise the presentation of waveforms and enhance the quality of sound using our unique Dynamic Digital Noise Reduction (DDNR) system and gel filter. Our state of the art digital Doppler unit have many new features.

## D900 Mini Doppler

D900 is a low cost audio only, non-directional Doppler, principally used for vascular assessment, but capable of fetal heart detection if used with an obstetric probe. The product is used extensively for ABPI assessment in the community.

- Clear audio sounds of blood flow
- Perfect for ABPI measurements by community nurses or Doctors when combined with the EASY8 probe
- Compatible with all XS high sensitivity vascular probes
- Supplied with large carry bag
- Supplied with Gel
- Probes ordered separately



**HD0003** Mini Doppler

### HUNTLEIGH



5 Year  
Warranty



## Super Dopplex II SD2

The Dopplex SD2 provides bi-directional vascular information to the vascular professional, and provides audio fetal heart sounds if used with obstetric probes.

Use with the EX8 widebeam robe for easy location of brachial and pedal arteries

- Compatible with all XS high sensitivity vascular probes
- Provides bi-directional blood flow information
- Stereo audio output socket
- Supplied with Large carry bag
- Supplied with Gel
- Includes manufacturers warranty



**HD0004** Super Dopplex II

### HUNTLEIGH







5 Year  
Warranty

Probes sold  
separately see  
page 69

## Dopplex DMX Digital Vascular Doppler

The Dopplex DMX Digital Doppler, designed to improve performance in the vascular assessment of arterial disease (PAD), diabetic foot and wound management.

Our Bi-Directional waveform is uniquely generated from the digital Doppler spectrum. This gives the clinician objective evidence to assist in the diagnosis of vascular disease that other Dopplers may find difficult or impossible to achieve.

-  **Doppler & Arterial PPG Waveforms:** Displayed on a high resolution, colour screen
-  **Improved Audio:** Dynamic Digital Noise Reduction & gel filter
-  **Trace & Sound Storage:** Store and playback patient tests
-  **Improved Performance:** Special High performance probes
-  **Rechargeable:** Reduced running costs

- Bi-directional waveform generated from the DMX digital vascular doppler spectrum with auto scaling feature with a wide viewing angle
- Maximises accuracy and clarity of waveforms; essential for patients with poor blood flow
- Store waveforms and sounds on a micro SD card for review
- Stereo headphone connection socket
- All new HS probes have been calibrated and fine-tuned for optimum use, whilst an optional PPG probe provides easy and accurate measurement of toe pressures

**HDO092** Dopplex DMX with Alkaline Batteries

**HDO093** Dopplex DMX with Rechargeable Batteries & Charger

# HUNTLEIGH



Probes sold separately please see page 69



## Dopplex DFK - Diabetic Foot Kit

The Diabetic Foot Kit (DFK) is a unique combination of DMX Doppler, probes and accessories providing the Vascular, Diabetic or Lymphatic specialist with a system to aid the assessment of arterial disease and neuropathy.

Our lightweight Arterial Plethysmography (PPG) probe easily attaches to the DMX Doppler unit by simply swapping your Doppler probe with its adaptor. Arterial systolic pressure can be rapidly measured in patients with non-compressible arteries and can be repeated on the arms to determine the TBI.

### DFK includes:

- DMX Digital Doppler (See Above)
- Recharging kit
- PPG Probe, adaptor and gel
- Toe cuffs & inflator
- Arm/Ankle cuffs (latex free)
- Trigger operated sphyg
- EZ8xs Widebeam 8MHz Doppler probe
- Neuopen & box of tips
- Educational CD



**HDO094** Dopplex DFK - Diabetic Foot Kit

# HUNTLEIGH



## Dopplex ABI - Ankle Brachial Index Kit

The Ankle Brachial Index (ABI) kit is a unique combination of DMXR Doppler, Doppler probes and cuffs which provides the Wound care or vascular specialist with a system to help in the assessment of arterial disease prior to bandaging. Doppler waveforms can be stored on the internal memory and reviewed at any time.

### ABI Kit Includes:

- DMX Digital Doppler
- EZ8xs wide beam 8MHZ Doppler probe
- VP5xs high sensitivity Doppler probe for deep vessels and oedematous limbs
- Recharging kit
- Trigger operated sphyg
- Large and small arm/ankle cuffs (latex free)
- Educational CD
- Probe Gel



HUNTLEIGH



A

Dopplers

**HDO095** Dopplex ABI - Ankle Brachial Index Kit

## Doppler Mobile Stands

Mobile Stands from Huntleigh, a great option for use with Huntleigh dopplers. Each stand is designed to provide a lightweight, portable holder that is easily manoeuvred.

- Five arm wheel base ensures stability and ease of manoeuvre
- Includes a basket for storage
- Fully height adjustable

**HDO073** Mobile Stand for Huntleigh Hand Held Dopplers

**HDO097** Mobile Stand for Huntleigh Digital Dopplers

HUNTLEIGH

### HDO073

#### For use with:

- D900
- SD2
- D920
- D930



### HDO097

#### For use with:

- DMX
- SRX
- SR2
- SR3



## Dopplex High Sensitivity Probes

Huntleigh High sensitivity probes are individually fine-tuned and tested to ensure high performance and produce sound and sensitivity that gives the user clarity and accuracy like no other.

**EZ8:** 8MHz Widebeam Vascular probe allows easy location of vessels. Easy to maintain vessel contact during inflation & deflation

**VP4-XS:** 4MHz Vascular probe for detection of deep lying vessels

**VP5-XS:** 5MHz Vascular probe is used for oedematous limbs and deep lying vessels. An ideal probe as an adjunct to the EZ8 for ABPI measurements

**VP8-XS:** 8MHz Vascular probe is ideal for easier detection of peripheral vessels and calcified arteries

**VP10-XS:** 10MHz Vascular probe is perfect for detecting smaller vessels in specialist superficial applications

**OP2-XS:** 2MHz Fetal probe offers enhanced performance throughout pregnancy

**OP3-XS:** 3MHz Fetal probe, preferred by some clinicians for use in early pregnancy (from 8-10 weeks)

**HDO011** EZ8 8MHz Widebeam Vascular Probe

**HDO016** VP4-XS 4MHz Vascular Probe

**HDO017** VP5-XS 5MHz Vascular Probe

**HDO018** VP8-XS 8MHz Vascular Probe



HUNTLEIGH

**EZ8**



**OP2**



**VP4/5**



**OP3**



**VP8**



**VP10**



**HDO019** VP10-XS 10MHz Vascular Probe

**HDO020** OP2-XS 2MHz Fetal Probe

**HDO021** OP3-XS 3MHz Fetal Probe

## Dopplex ABility - Automatic Ankle Brachial Index System

The Dopplex Ability is an automatic ABI system that correctly measures systolic pressures in all four limbs, complying with current guidelines. Automatic systems which measure the pressure in only one arm, contradict the guidelines and may miss or incorrectly classify cases of PAD.

### Why Invest?

- Rapid Bi-Lateral ABI measurements takes less than 5 minutes per patient without the need for a clinician – In a typical 3 hour surgery, 33 patients could be tested
- 95% Accuracy when compared to Ultrasound Duplex imaging (Lewis et al, 2016)
- International Guidelines (ESC, 2011) state that ABI should be undertaken on patients with suspected PAD as first line test and PVR waveforms as second line test. The Dopplex Ability printout provides both of these requirements on one unique printout to aid the clinician in their diagnosis
- **Dimensions:** 160 x 260 x 260mm
- **Weight:** 3kg

Doppler ABI	Ability ABI	Oscillometric ABI
>1.3	✓	✓
1.0-1.3	✓	✓
0.8-0.99	✓	✓
0.5-0.79	✓	✗
<0.5	✓	✗

### Accessories:

**HDO082** Dopplex ABility Standard Paper - 5pk

**HDO083** Label Paper - 5pk

**HDO084** Adult Size Cuff Set - 22 to 36cm

**HDO079** Dopplex ABility Large Size Cuff Set - 34 to 46cm

HUNTLEIGH

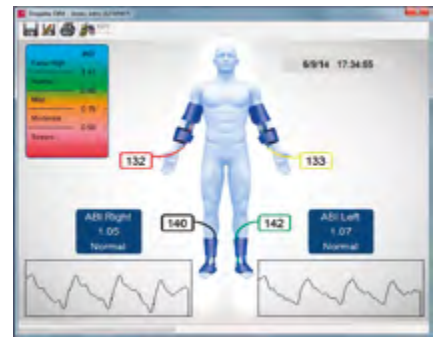

Guest et al highlighted only 16% of patients with foot or leg ulcers had an ABPI recorded\*

\*Guest JF, et al. " Health economic burden that wounds impose on the National Health Service in the UK" BMJ Open 2015

**HDO075** Automatic Ankle Brachial Index System

**HDO076** Fixing Plate - For Trolley, Wall or Couch mount

**HDO077** Trolley - Requires fixing plate

**HDO078** Wall Mount - Requires fixing plate

**HDO080** Carry Bag

**HDO081** Infection Control Sleeves - Box of 10

## Mindray M9 Ultrasound System

The M9 is an innovative premium portable Ultrasound platform facilitating a wide range of clinical Ultrasound examinations that in the past would have been carried out on a Premium Cart-based machine.

The M9 is extremely user friendly, the control panel enhances workflow, speed and accuracy of examinations. Premium capability in an easily portable system for Radiology, Vascular, Cardiac and Point of Care imaging.

- Advanced technologies such as mQuadro architecture and Single Crystal transducer technology provides the Clinician with the ability to image a wide range of patient sizes.
- Single crystal transducers with 3T™ technology
- Echo Boost™ cardiac image optimisation
- Improved penetration for technically difficult patients
- Large 15.6" high resolution LED monitor
- Easy to use controls and intuitive interface
- Durable magnesium-alloy case
- Advanced ergonomic cart available
- Full suite of transducers for a wide variety of applications



**HDO024** Mindray M9 Ultrasound System



## Mindray MX7 Ultrasound System

The MX7 from Mindray is an outstanding portable ultrasound system, designed with direct input from customers, and offering the perfect combination of ground-breaking imaging technologies, a host of ergonomic features, and one of the lightest, thinnest, laptop designs on the market.

There's a comprehensive range of transducers for all general imaging applications as well as a number of advanced features to support fast and confident decisions.

The first portable ultrasound system to include Mindray's pioneering ZONE Sonography® Technology (ZST+). This virtual beamforming platform gives clinicians powerful image acquisition and processing capabilities, resulting in high contrast resolution, excellent uniformity and reduced motion artefacts.

- Advanced tools to support with cardiovascular evaluation, needle guidance and obstetric examinations
- HD Scope - improves detail and contrast
- Greater image clarity with built-in large 15.6" high-resolution screen display
- Easy to use with customisable 12.3" touchscreen
- Ergonomic cart with three transducer ports available
- Extremely portable at 3kg and a thickness of just 44mm
- Optional U-Bank battery provides up to eight hours of scanning without need for mains power
- Robust magnesium-alloy shell
- Seamless connectivity to third-party EPR systems

**HDO022** Mindray MX7 Ultrasound System



A

Dopplers

## Mindray ME8 Ultrasound System

Greater image clarity and exceptional intelligence all packed into an ultra-light, compact laptop. The Mindray ME8 point-of-care ultrasound system combines best-in-class image quality with an intuitive user experience to help ensure a reliable and efficient diagnosis.

Suitable for a variety of examinations and procedures in critical care, anaesthesia and emergency areas. One of the lightest and thinnest laptop ultrasound machines on the market. Its robust shell and durable fluid resistant control panel make it ideal for withstanding the everyday rigours of clinical environments.

- Best-in-class image quality with ZONE Sonography® Technology (ZST+)
- Single crystal transducers with 3T™ technology for improved penetration and resolution
- AI analysis tools to support lung, cardiac and fluid management
- Needle guidance tools include iNeedle+™ and eSpacial Navi™
- Large 15.6" high-resolution monitor with a 185-degree hinge
- Easy to use with customisable 12.3" touchscreen
- Easy to clean with its lockable and seamless control panel
- Ergonomic cart with three transducer ports available
- Extremely portable with a weight and thickness of 3kg and 44mm
- Up to eight hours of power with U-Bank (optional)
- Strong magnesium-alloy shell for durability
- Vendor-neutral EPR connectivity

**HDO023** Mindray ME8 Ultrasound System



## A1 Acoustic Rhinometer

Acoustic Rhinometers allow a very rapid non invasive examination of the nasal cavity using a sound pulse technique.

It quantifies nasal airway structure and offers a static profile indicating where the obstructions are and how severe they are in real units.

Reflections of the sound pulse are processed by a PC providing a plot of the area as a function of distance into the nose.

- Animal, Paediatric and Adult sound tubes
- PC Based with Clinical and Research versions
- Pre/Post challenge or operative comparisons
- Can be interfaced through a USB PC connection
- Anatomical or conical nose pieces for airtight connection
- In built calibration facility with adjustable scale setting
- Colour display and A4 size printouts
- Software for Windows XP to Windows 10 is available

### Calculation of:

- The first two minimum areas
- Position where minimas were found
- The volume between two distances

### A1 Clinical/Research option additionally provides:

- Result verification software facility with CV% calculation
- A report generation facility which provides:
  - Editing of resultant curves
  - Volume measurement of 4 sectors
  - Cross section calculation at 6 points
  - Pre/post graphical display, ratio calculation and % change
- Artificial nose and straight tube for setting up and performance verification
- Capability to be called from a patient database and return values to the database

HRS730 A1 Clinical - Software & Consumable Starter Pack

HRS731 A1 Clinical/Research - Software & Consumable Starter Pack

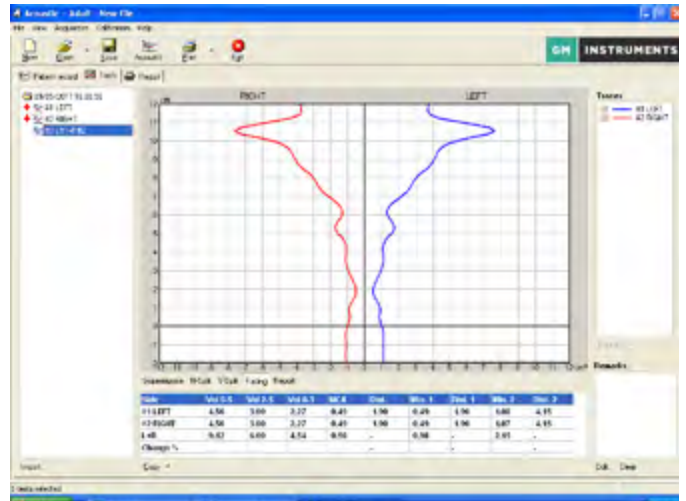

## A1/NR6 Linked

All the benefits and features of the A1 Acoustic Rhinometer combined with the NR6 Rhinomanometer

### A1 Acoustic Rhinometer benefits/features:

- PC capability with software for up to Windows 10
- Animal, Pediatric and Adult sound tubes
- Pre/Post challenge or operative comparisons
- Can be interfaced through a USB PC connection
- Anatomical or conical nose pieces for airtight connection without distortion

### NR6 Rhinomanometer benefits/features:

- Diagnostic facilities
- Software for Windows XP to Windows 10 is available
- Database system with % change calculation
- Pre/Post challenge or operative comparisons
- Can be interfaced through a USB PC connection
- Includes all approved techniques including:
  - “4 phase high resolution”
- Active anterior, posterior, standard and Broms angle, plus Vertex and Effective resistance values

HRS736 A1/NR6 Clinical/ Research - Software & Consumable starter Pack



## NR6 Rhinomanometer

The NR6 calculates nasal airway resistance by measuring nasal flow and the pressure producing that flow. It quantifies nasal airway resistance and offers a physiologically normal, dynamic measurement function. It can indicate the possibility of a number of medical conditions.

The NR6 can be used for active anterior or posterior rhinomanometry, with either the Broms or standard technique as approved by the International Standardisation Committee.

In addition it will calculate and display either the Rohrer coefficients or the Broms angle relating to the resultant curves.

- Diagnostic facilities
- Clinical and Research versions available
- Database system with % change calculation
- Pre/Post challenge or operative comparisons
- Can be interfaced through a USB PC connection
- Software for Windows XP to Windows 10 is available

Includes all approved techniques, including “4 phase high resolution”, plus active anterior, posterior, standard and Broms angle, resistance values, the new plus vertex and effective resistance values, in the research version

**HRS732** NR6 Clinical - Software & Consumable Starter Pack

**HRS733** NR6 Clinical/Research - Software & Consumable Starter Pack



**The NR6 Clinical/Research model additionally provides:**

- Flow and pressure curves displayed in a y/t format, with the calculation of Vertex and Effective resistance and their logarithmic values.
- A batch test facility, which allows data runs to be repeated, and mean, standard deviation and coefficient of variance calculations to be displayed and printed.
- Data exportation facilities are built in which allows “raw” data in a number of formats to be provided for statistical analysis and other purposes.
- Capability to be called from a patient database and return values to the database.
- A Rhinocal unit, allowing the calibration to be checked.

## NV2 Rhinospirometer

Allows the measurement of partitioning of airflow between two nasal passages and provides a Nasal Partitioning Ratio (NPR).

Used with subjects who have a Septal Deviation, clinical work has identified a key ratio, above which subjects are likely to benefit from surgery and below which, they are unlikely to benefit.

As the patient breathes in through two nasal adaptors, the volume of air through each side of the nose is measured. A nasal partitioning ratio (NPR) can be easily calculated from the nasal volumes.

Clinical work published suggests that NPR values within a range of +/-0.3 are normal while figures greater than that indicate a degree of asymmetry, which may benefit from surgery.

- Aids selection of patients for Septoplasty
- Software compatible with Windows 10
- Rapid test which requires minimal patient co-operation
- Provides the user with documented confirmation of the success of the procedure
- Pre/Post challenge or operative comparisons
- Anatomical or conical nose pieces for rapid connection

**HRS734** NV2 PC Linked - Consumables Starter Pack



## ProPulse® Ear Irrigator ONE PAGE

Combining modern design with classic ProPulse® features enabling the most effective patient care.

Safety oriented operation provides an easy to use solution to irrigation treatment requirements.

A full range of essential ear care products are available which complement the ProPulse® Ear Irrigator. These products include ProPulse® Single Use QrX™ Tips, ProPulse® Cleaning Tablets, ProScoop™ Ear Wax Removal Scoop and the ProPulse® ProTect™ Shoulder Capes.

### Key features include:

- Variable pressure control providing safe water delivery
- Ergonomic handle design facilitates easy tip removal
- Footswitch enables hands-free operation
- ProPulse® Contrapulse® water delivery system
- Utilises ProPulse® QrX Technology



HSU540



HSU248.2



HSU536.6



HSU537.1

### Ear Irrigator & Accessories

HSU553	ProPulse® Ear Irrigator PP – inc 100 QrX Tips
HSU555	ProPulse® Ear Irrigator PP – inc 10 QrX Tips
HSU541.1	ProPulse® QrX Tips Single Use 100pk
HSU541.3	ProPulse® replacement power adaptor
HSU541.4	ProPulse® Mushroom Value & Washer – 5pk
HSU541.5	ProPulse® Universal Foot Switch
HSU541.6	ProPulse® PP Reservoir & Lid

### Further Propulse® Accessories

HSU540	ProPulse® ProScoop™ Ear Wax Removal Scoop – 40pk
HSU248.2	ProPulse® Cleaning Tablets – 200 per tub
HSU537.1	ProPulse® ProTect™ Shoulder Cape – 36 capes
HSU536.6	ProPulse® Carry Case
HSU248.1	ProPulse® Disposable Jet Tips 100pk for ProPulse® II & III
HSU251	Mushroom Value & Washer for ProPulse® III / NG – 5pk

## ProPulse® PP Starter Kit

### All you need in one simple kit!

This irrigation starter kit includes the following products:

- ProPulse® Ear Irrigator (See above for further details)
- ProPulse® ProScoop™ Ear Wax Removal Scoop
- Replacement Mushroom Valves and Washers – 5 of each
- Soft ProPulse® Carry Case
- ProPulse® QrX Tips Single Use (Pack of 100)
- ProPulse® Cleaning Tablets
- ProPulse® ProTect™ Cape



HSU557 ProPulse® PP Starter Kit

## mirage Health Group | PROPULSE®



## ProPulse® Ear Irrigator

The Propulse® ProScoop™ has been designed in conjunction with a leading ear care specialist to facilitate the manual removal of ear wax before, during and after the ear irrigation process.

- Scoop end designed by ear care specialists to allow for easy removal of ear wax.
- Indicator mark on scoop shaft at 15mm (±0.5mm) to show depth of penetration into ear.
- Serrated end designed for easy application of cotton wool - for mopping the ear out after irrigation.
- Non slip shaft for added safety.
- For professional use only.



PROPULSE®



HSU540 Propulse® ProScoop™ Ear Wax Removal Scoop – 40pk £62.00

## ProPulse® Cleaning Tablets

Propulse Cleaning Tablets are formulated for use with Propulse Ear Irrigators.

They ensure that the irrigator is cleaned effectively without damaging the pump and working components of the unit as some other cleaning agents can.

- Convenient, simple to use cleaning tablets
- Use one per day prior to using the machine in accordance with cleaning guidelines

PROPULSE®



HSU248.2 Propulse® Cleaning Tablets – 200 per tub

## ProPulse® ProTect™ Shoulder Cape

The ProTect™ Cape can be used on either shoulder and is quickly and easily fitted to the patient. Its 3 ply design combines an absorbent paper material with a waterproof backing layer to provide maximum protection.

- Helps prevent cross infection
- Can be used on either shoulder
- Environmentally friendly
- May be disposed of with clinical waste
- Supplied in dispensing box of 36 capes

PROPULSE®



HSU537.1 Propulse® ProTect™ Shoulder Cape – 36 capes

## Guardian Project 101 Ear Irrigator

Utilising the most modern production methods, the Guardian Project 101 was designed to fulfil the most demanding healthcare requirements for a reliable, leak free and easy to use machine that is not expensive to run and does not require constant maintenance and subsequent down time.

- Sliding flow regulator conveniently mounted in handle. Water flow can be temporarily stopped by sliding regulator to off position or flow regulated by sliding control to desired position
- Integral wall mount frees up valuable work space by wall mounting the Project™ (can be easily removed for cleaning/maintenance etc)
- Digital control of water pressure and flow is easy to operate and remains constant and reproducible
- Longer mains lead and handle hose means the machine can be sited where it is most convenient
- Ultra thin atraumatic tips help operator visibility and direction of water flow
- Oversized water reservoir silicone washers reduce incidence of leaks
- Tips held securely yet very easy to remove and replace
- Flat control panel is easy to keep clean
- On board tip and/or instrument storage
- Quiet operation
- Economically priced Non slip shaft for added safety.
- For professional use only.



HSU1031 Guardian Project 101 Ear Irrigator

HSU1031.1 Pack of 100 tips for Project

# Comprehensive and easy to use integrated ECG system



With the seca CT330 and CT331 seca offers an elegant and effective way to record a twelve lead ECG, including full system integration into leading NHS clinical systems EMIS\* and SystemOne.



- + Medical grade quality PC ECGs from German manufacturer seca
- + Easily connectable by USB (seca CT330) or USB and Medical Bluetooth (seca CT331)
- + Fast, easy to use and safe transmission of results – improving patient safety
- + Complete measurement takes only 3 clicks
- + Reducing admin and appointment time
- + PDF ECG report and read code automatically uploaded to patient file
- + Work paperless or print A4 ECG if you want to (no thermal ECG paper needed)
- + UK software support and Nationwide Field Engineers for onsite assistance

Experience our integration workflow videos



## seca CT8000i-2 A4 12 Lead ECG

A compact, portable and user-friendly device. The CT8000i-2 allows for quick, easy and reliable ECG acquisition.

- **Compatible with leading EMR systems:** emis, SystemOne & Vision
- **On-screen ECG preview, review prior to printing, save paper**
- **5" colour high resolution LCD display**
- **High volume internal memory: storage of up to 100 ECGs**
- High sampling frequency and a large frequency band, provides optimal signal quality for adult and paediatric ECG's
- Advanced clinical interpretation ETM algorithm
- Designed with ease of use in mind - enter patient data at the touch of a button - preview ECG prior to printing and a simplified keyboard - taking an ECG has never been easier
- QTc interval - ideal for Mental Health
- QTc formulas: Bazett, Fredericia, Framingham or Hodges
- Automatic PDF export to USB stick
- Sealed keyboard ensures infection control
- Resistant to NHS cleaning agents, including Clinell
- **Dimensions:** 285 x 189 x 61mm (L x W x H)

**HCE1157** seca CT8000i-2 12 Lead ECG

**HCE030.2** Extended 2 Year Comprehensive Warranty for CT8000i-2

**HCE033** seca CT500-2 Height adjustable ECG Cart with storage

**HCE150.1** Covidien Q-Trace GOLD Electrodes - 500pk

**HCE150.2** 5400 Q-Trace ECG TAB Electrodes - 500pk

**HCE150.3** seca Q-tab Electrodes - 500pk



B

ECG Machines & Accessories



## seca CT331/CT330 PC Based Interpretive ECG Machines

Enjoy the flexibility of use in large clinicrooms with a wireless connection, or via a USB cabled option to plug in if needed. Cable-free operation also grants a higher freedom of movement and reduces trip hazards. Send the data to your EMR if you like and work paperless from now on. Profit from minimising time-consuming data entry, with SystmOne EMIS integration.

- **Fully integrates with EMIS & Systmone (Vision integration coming soon)**
- **CT331** transfers via USB cable & Bluetooth connectivity and includes an inbuilt battery
- **CT330** only transfers via USB cable connection
- Transfer data via Bluetooth or USB cable
- Rechargeable inbuilt batteries for up to 12 hours of runtime
- Brilliant recording quality of all twelve leads with a sampling rate of up to 32 kHz
- LED's for ECG quality and individual lead-on electrode check
- Clear surface for quick and easy disinfection
- Vision integration coming soon (contact us for details)
- Resistant to NHS cleaning agents, including Clinell
- **Net weight** 140 g
- **Dimensions (W x H x D)** 78 x 23 x 118 mm

**HCE404** seca CT331 PC Based Interpretive ECG with Bluetooth & USB

**HCE403** seca CT330 PC Based Interpretive ECG with USB

**HCE404.1** Extended 2 Year Comprehensive Warranty for CT331

**HCE403.1** Extended 2 Year Comprehensive Warranty for CT330

**HCE351.1** Seca Bluetooth USB Dongle (For CT321/CT331)

**HCE150.3** seca Q-tab Electrodes - 500pk



\*emis integration subject to annual software licence, contact for details

# Robust and reliable: ideal for busy clinics

- + Portable and clinic based ECG machines
- + Compatible with all leading EMR systems
- + Brilliant signal quality for adult and/or paediatric ECG's

**3** year  
warranty

**systemone**  
THE PATIENT RECORD

Compatible with all EMR systems



seca CardioPad-2

Ultra-portable, touch screen 12 lead ECG  
with Wi-Fi and advanced interpretation



seca CT8000i-2

Compact and portable interpretive  
12 lead ECG machine

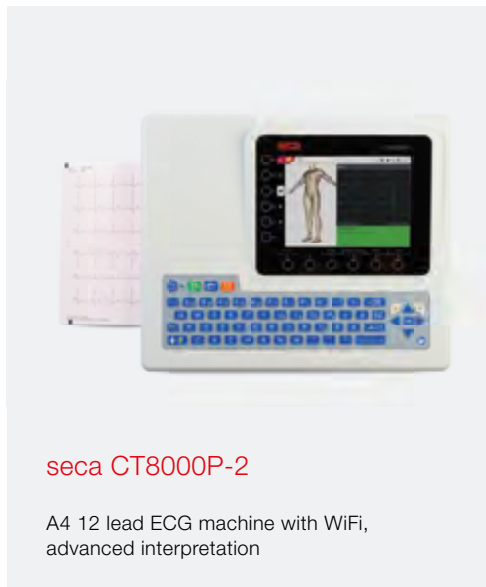

seca CT8000P-2

A4 12 lead ECG machine with WiFi,  
advanced interpretation



seca CT500-2

Height adjustable  
ECG Cart



## seca CardioPad-2 Portable Tablet ECG

The next generation, ultra-portable, innovative seca CardioPad has become even lighter. Although it's extremely compact, it features an in-built printer, renders 12 ECG traces simultaneously and is capable to process data to your the EMR system.

- **Compatible with leading EMR systems:**  
emis, SystemOne & Vision
- **Wi-Fi connectivity and seca link software included**
- **Lead reversal, warnings and misplaced electrodes are immediately displayed before ECG acquisition**
- **On-screen ECG preview, review prior to printing, save paper**
- **High volume internal memory: storage of up to 350 ECGs**
- 8" colour high-resolution screen with anatomical electrode placement adviser - helps to correctly place the electrodes
- On-screen preview of ECG, review prior to printing, save paper
- Flat device design enables ease of cleaning
- Advanced algorithms, with high sampling frequency and band
- ETM: one of the industry leading 12-lead ECG interpretations
- ETM Sport: first automated ECG interpretation designed for athletes, based on the Seattle Criteria
- 12-lead ECG interpretation programs for adults and children
- QTc formulas: Bazett, Fredericia, Fremingham or Hodges
- Resting ECG Rhythm Strip: all 12 leads record for up to 4 mins
- High volume internal memory: storage of up to 350 ECGs
- Resistant to NHS cleaning agents, including Clinell
- **Dimensions:** 230 x 160 x 30 mm (L x W x H)

**HCE1159** seca CardioPad-2 Portable Tablet ECG

**HCE372.1** Extended 2 Year Comprehensive Warranty for CardioPad-2

**HCE372** Carry Case for CardioPad-2 ECG Machine

**HCE1162** ECG Paper for CardioPad-2 ECG Machine - 50 ECGs

**HCE150.3** seca Q-tab Electrodes - 500pk

seca



3 Year Warranty

systemone

EMIS & Vision Compatible



Free Demo



HCE1163



## seca CT8000P-2 12 Lead ECG

The seca CT8000P-2 is a highly reliable and robust ECG machine with easy data access and fast transmission of ECG reports to your EMR system. It can receive and send data via Wi-Fi or LAN, preview all 12 ECG leads simultaneously on its large screen.

- **Compatible with leading EMR systems:**  
emis, SystemOne & Vision
- **Wi-Fi connectivity and seca link software included**
- **On-screen ECG preview, review prior to printing, save paper**
- **PDF ECGs auto download to your pc via Wi-Fi or LAN**
- **High volume internal memory: storage of up to 350 ECGs**
- 8" colour high-resolution screen with anatomical electrode placement adviser - helps to correctly place the electrodes
- Lead reversal, warnings and misplaced electrodes are immediately displayed before ECG acquisition
- Advanced algorithms, with high sampling frequency and band
- Delivers optimal signal quality - ideal tool for paediatric ECGs
- ETM: one of the industry leading 12-lead ECG interpretations
- ETM Sport: first automated ECG interpretation designed for athletes, based on the Seattle Criteria
- QTc formulas: Bazett, Fredericia, Fremingham or Hodges
- Resting ECG Rhythm Strip: all 12 leads record for up to 10 mins
- Resistant to NHS cleaning agents, including Clinell
- **Dimensions:** 384 x 319 x 90mm (L x W x H)

**HCE1158** seca CT8000P-2 12 Lead ECG

**HCE242.1** Extended 2 Year Comprehensive Warranty for CT8000P-2

seca



3 Year Warranty

systemone

EMIS & Vision Compatible



Free Demo



HCE033



**HCE1161** ECG Paper for CT8000P-2 - Z-Fold, A4

**HCE033** seca CT500-2 Height adjustable ECG Cart with storage

**HCE150.1** Covidien Q-Trace GOLD Electrodes - 500pk

**HCE150.2** 5400 Q-Trace ECG TAB Electrodes - 500pk

**HCE150.3** seca Q-tab Electrodes - 500pk

## seca CT500-2 Height adjustable ECG Cart with storage

seca®

Hospital quality mobile cart provides easy transport for ECG machines and accessories. Height adjustable cart with utility storage bin and dividers.

- Compatible with all seca ECG machines and any ECG brand which fits onto the cart top
- 4 swivel caster wheels, 2 of which are braked – securing the cart when required
- Simply adjust the height using the foot pedal, customising the cart to suit all staff (height adjustable from 81.2cm - 102.1cm)
- Cart column includes cable covers / cord organiser
- Non-metallic top to the trolley
- Incorporating a spring loaded arm for control of patient cable & storage basket for electrodes and paper etc.
- Universal flat top trolley which all models of seca ECG machines will fit onto
- Resistant to NHS cleaning agents, including Clinell
- **Max height:** 102.1cm
- **Min height:** 81.2cm
- **Width:** 57.7cm
- **Depth:** 48cm
- **Cart top:** 42x43cm (WxD)
- **Weight:** 21.3kg



**HCE033** seca CT500-2 Height adjustable ECG Cart with storage

## Welch Allyn® CP150™ ECG Machine

Designed for your primary care practice, the CP 150 ECG helps streamline your workflow with EMR connectivity, clinical decision support and full-size printouts with a simple touchscreen interface and fast one-button operation to help you keep your staff productive and your tests accurate.

- ECG print previews can help save time and reduce paper costs, better for the environment
- Seven-inch colour, touchscreen display with fast operation for easy entry of patient data
- 3, 6, or full 12-lead ECG preview options
- Battery operation lets you easily transport your device to the patient
- Instant-on powers the device up quickly to take an ECG at a moment's notice
- Free training for practice staff included

**Dimensions:** 48.7 x 56.7 x 32.2cm

**Weight:** 10.1 Kg

**HCE252** CP150™ ECG Machine with interpretation

**HCE245.2** Welch Allyn® Trolley

**HCE245.3** Welch Allyn® Cable Arm for CP150 Trolley

**HCE245.4** Welch Allyn® CP150 Paper

**HCE245.9** Welch Allyn® Resting Pad Electrodes - 5000pk



## Welch Allyn/Mortara Eli 150 ECG

The compact and lightweight ELI 150c Electrocardiograph provides comprehensive functionality in an ultra-portable device.

Widely recognized Mortara VERITAS™ resting ECG interpretation algorithm uses gender-specific and adult and pediatric criteria to provide a silent second opinion for resting ECG interpretation

- **Optional Eli Link Software for full colour PDF attachments to all patient record systems**
- Mortara VERITAS™ ECG Interpretation software for accurate interpretation
- High-res color display provides 12-lead ECG preview and post-acquisition review
- Captures best 10 seconds of ECG data from memory, reducing need for repeat ECGs
- 200 ECG patient memory
- Replaceable lead wires & lead off indicator
- IEC banana clips, clip adaptors (10)
- 100 x tab electrodes
- ECG Paper
- 2 Year warranty
- Dimensions: 29.2 x 30.5 x 10.2cm. Weight: 3.3kg

**Choice of wireless or ethernet cable connection to PCs, with remote control for ECG acquisition.**

**HCE1140** ECG with wired patient cable & ethernet cable to send ECG to PC

**HCE1141** ECG with wired patient cable & wireless option to send ECG to PC

**HCE1142** ECG with wireless patient cable & ethernet cable to send ECG to PC

**HCE1143** ECG with wireless patient cable & wireless option to send ECG to PC

**Baxter**



2 Year Warranty

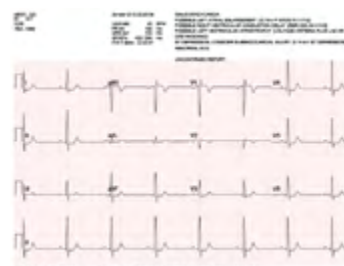

**emis**  
EMIS is a trademark of EMIS Limited

**HCE1144** Carry Case for Eli 150

**HCE1145** Eli 150 trolley cart with bin and 2 swiveling casters

**HCE1146** Thermal Paper: 200 sheets per pack & 24 packs per case

## Welch Allyn® ELI230 Resting ECG

The Welch Allyn® ELI 230 Resting ECG offers complete functionality in a compact, portable device.

A cost-effective ECG solution offering accurate and reliable adult/pediatric ECG interpretation and full-size printouts. The color display provides real-time preview of three, eight or twelve leads of ECG data, as well as post-acquisition review of acquired ECG.

The VERITAS™ resting ECG interpretation algorithm uses gender-specific and adult and pediatric criteria to provide a silent second opinion for diagnostic interpretation.

- High-resolution colour display provides real-time preview and review of 12-lead ECG
- Best 10 technology captures the best 10 seconds of recorded ECG from system memory, helping to ensure clean ECGs and eliminating the need for repeat tests
- Uses the highly regarded VERITAS™ ECG interpretation algorithm, powered by Mortara
- A4 thermal printer, 210mm roll paper
- 20 ECG patient storage, expandable with USB stick
- Carry case available to protect the unit

**HCE1150** ELI230 with Interpretation and wired AM12 patient cable

**HCE1151** ELI230 with Interpretation and wireless patient cable

**Baxter**



2 Year Warranty



**HCE1152** Optional Carry Case for ELI230

**HCE1153** Paper Rolls (12pk)

## Welch Allyn® H3+™ Digital Holter Recorder

**Baxter**



The H3+ Digital Holter Recorder is small and lightweight, making it very comfortable for patients. It provides 3-channel recording with standard pacemaker spike detection, and supports continuous recording for up to two days with just one AAA battery.

Featuring a full graphic display to preview ECG waveforms during patient hookup—which can be performed in any convenient location. Recordings are downloaded via USB cable to the Holter Analysis System, featuring best-in-class VERITAS™ signal processing and analysis capabilities.

Recordings can also be uploaded from a computer via internet with the required software – **Contact us for more details**

- Records 3 channels of continuous ECG data for up to 7 days
- Compact, light (weighing just 28g) and easy to use
- Features a full graphic display to preview ECG waveforms during patient setup
- Discreet recorder allows the patient freedom to perform routine activities that may lead to improved presentation of reported symptoms
- Just one AAA battery required
- Event button allows patients to mark specific events that occur during the test
- Recordings are imported and rapidly analysed with the Express holter software
- **Express software is available separately**



**HCE1148** H3+ 7-Day Digital Holter ECG Package

**HCE1148.1** H3+ 48-hr Digital Holter ECG Package

## Welch Allyn® XScribe Stress ECG

**Baxter**



Through innovative technologies and a smart design, the XScribe Cardiac Stress Testing System helps solve common challenges associated with cardiac stress testing exams.

- The Wireless Acquisition Module (WAM™) digitally transmits diagnostic quality 12-lead ECG data, eliminating the need for direct patient connection
- The highly regarded VERITAS signal processing algorithms provide exceptional accuracy in beat detection and noise rejection, resulting in superior identification of events for both adult and paediatric patients
- With comprehensive presentation of clinical data, the XScribe presents continuous ST trends and profile, ST level and slope for all 12 average complexes and auto comparison with reference complexes
- Innovative technology for noise and baseline artefact reduction ensures signal quality, while preserving the integrity of the ECG tracing
- Enhanced Full Disclosure Mode provides continuous beat-by-beat storage of waveforms and events allowing for retrospective review and post-test inclusion within the final report
- Enhanced device security with industry-leading encryption of patient data
- XScribe is designed for simplified integration into EMR systems, minimising manual steps such as data entry and automating electronic charting of the report.
- Integration technologies include PDF, XML, plus bidirectional HL7 and DICOM



**HCE1155** Xscribe Sytem with Treadmill & Touchscreen Monitor

**HCE1156** Xscribe Sytem with Treadmill & Non-Touchscreen Monitor

## Welch Allyn® CardioPerfect™ PC ECG System

Improve accuracy, enable immediate access to patient diagnostic information and enhance your practice's efficiency, as part of the CardioPerfect Workstation suite. Automatically transfer patient information and test data into most EMRs without redundant work steps, misidentified patients, or delays from copying, scanning and shredding ECG reports.

Use this upgradeable system to leverage investment by adding ambulatory blood pressure (ABPM) modules at your convenience to give you complete cardiopulmonary testing capabilities.

- Use with a single computer or enterprise wide network, with or without an EMR
- Help improve patient care by overlaying previous ECGs to spot differences
- Improve exam efficiency with a 4x3 preview prior to printing
- High quality and reliable readings help eliminate repeat ECGs
- Automatic ECG measurements speed physician review and interpretation
- Interpret and edit report on screen for patients up to 1 day old
- Easily monitor patients with intermittent arrhythmias
- Programmable report formats print on 8.5 x 11 paper, using your current printer
- Supplied with 5m USB cable & free training for practice staff
- **Dimensions:** 25.9 x 32.9 x 11.2cm
- **Weight:** 1.85 Kg

Baxter



1 Year Warranty

systemone



**HCE203** CardioPerfect PC Based ECG System

**HCE203.3** Systemone Interface

**HCE245.9** Welch Allyn® Resting Pad Electrodes - 5000pk

ECG Machines & Accessories



5 Year Warranty

**HCE387** Vitalograph 12 Lead BT ECG

**HCE387.1** Vitalograph Spirotrac 6 Spirometry Software

**HCE390** Disposable ECG Electrodes - 30pk

## Vitalograph 12 Lead BT ECG

The Vitalograph BT12 ECG combined with our Spirotrac® software is a powerful electrocardiograph. Free 5-Year Warranty with unlimited technical support if registered within 30-days of purchase. Includes FREE online device training with certificate.

- With its lightweight compact design, it is ideal as both a stationary and portable device providing 12-Lead Resting ECG instantly on your own PC, laptop, or tablet.
- Transmission of the ECG trace is wireless with no leads to trip over, providing excellent signal quality, less artifact and ensuring minimal patient discomfort.
- Intuitive Spirotrac PC software provides a user-friendly workflow.
- Accurate and sensitive interpretation is provided by the scientifically recognized University of Glasgow algorithm which is one of the top resting ECG interpretive algorithms in the world, tried and tested for more than 35 years.
- Can be used with both Spirotrac V and Spirotrac 6 software (not included).
- Included as standard is Vitalograph Connect middleware software for connecting to all major EHR/EMR systems via HL7 and GDT.

## ECG Electrodes



HCE1050/1



HCE145



HCE144.1



HCE150.3



HCE261



HCE148

**HCE1050** H34LG Electrode - 300pk

**HCE1051** H34SG Universal Electrode - 200pk

**HCE144** Supatab Resting Electrodes - 100pk

**HCE145** Supatab Resting Electrodes - 500pk

**HCE144.1** Blue Sensor Electrodes - 25pk

**HCE148** Ambu WhiteSensor 0415M Electrodes - 500pk

**HCE261** Red Dot Electrodes Adult - 50pk

**HCE390** Disposable ECG Electrodes - 30pk

## ComfiDilator®

The ComfiDilator® is designed to allow gentle opening of the cervix for IUCD fittings and other gynaecological procedures. Easy to use and double-ended to allow progressive dilation utilising the two sizes. Ergonomic design includes a thumb hold.

Sterile Single use Cervical Dilator - Individually packaged as 5's



**HCP1041** ComfiDilator® 3-4mm - 5pk

## ComfiKit IUCD Fitting Kit

Designed to simplify the process of fitting IUCDs

- Medium Disposable Vaginal Speculum with Lock x1
- Disposable Uterine Sound x1
- Rampley Sponge Holder x1
- Sims Uterine Scissor x1
- Teales Vulsellum Forcep x1
- ComfiGel® 5g Lubricant x1



**HCP1045** ComfiKit IUCD Fitting Kit

## PELIpack IUD Removal & Fitting

- PELIspec® Medium or PELIspec® Medium Long
- Pelican Spongeholder
- Pelican Vulsellum
- Pelican 3/4mm Dilator
- Pelican Uterine Sound
- Pelican Long Scissors
- Pelican Coil Remover
- Gallipot, Gauze, Drape & Tray



**HCP843** PELIpack IUD Removal & Fitting - Medium

**HCP844.2** Pelican IUD Fitting Only - Medium (Metal/Plastic)

**HCP844** PELIpack IUD Removal & Fitting - Medium Long

## Pelican IUD Pack

- PELIspec® Medium or PELIspec® Medium Long
- Metal Rampley Spongeholder Forceps
- Metal Teale Vulsellum Forceps
- Metal Hegar Dilator
- Metal Mayo Scissors
- Pelican Uterine Sound
- Pelican Coil Remover
- Gallipot, Cotton Wool Balls, Drape & Kidney Dish



**HCP850** Pelican IUD Pack - Medium PELIspec (4 pack)

**HCP851** Pelican IUD Pack - Medium Long PELIspec (4 pack)

## Pelican Dilator

Designed to gently dilate the cervical 'os' to facilitate access to the uterus, and is ideal for preparing the cervix for an intra-uterine device. The Pelican Dilator is tapered to allow gradual dilation in 1mm increments from 2mm to 6mm (using 2 devices).

- Strong but flexible with central thumb hold for ease of use
- Tapered ends allow gradual cervical dilation
- Smooth, rounded tips for reduced risk of perforation

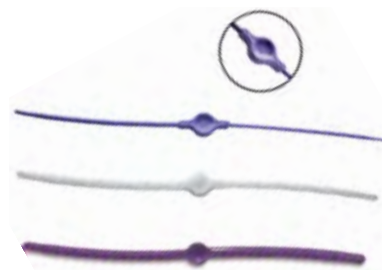

**HCP535** 3/4mm - 10pk

**HCP535.1** 3/4mm - 100pk

**HCP539** 7/8 - 10pk

**HCP539.1** 7/8 - 100pk

**HCP848** 5/6mm - 10pk

**HCP848.1** 5/6mm - 100pk

## PELIspec® Vaginal Speculum

The market leading PELIspec® is a strong, sterile, disposable vaginal speculum, 5 sizes available. Select sizes are also available without the locking mechanism. PELIspec® can be used for gynaecological procedures, including cervical screening, IUD fittings and vaginal examinations.

- Proven strength with built-in 'Fail-Safe' points
- Textured handles for enhanced grip
- Crystal clear for maximum visibility
- BPA and Latex-free
- Unique product identification number for traceability

**Start Packs Include: 5 Small, 15 Medium & 5 Medium Long**

**HCP057** With Lock - Small 25pk

**HCP057.1** With Lock - Virgin 25pk

**HCP058** With Lock - Medium 25pk

**HCP059** With Lock - Medium Long 25pk

**HCP059.1** With Lock Broad 25pk

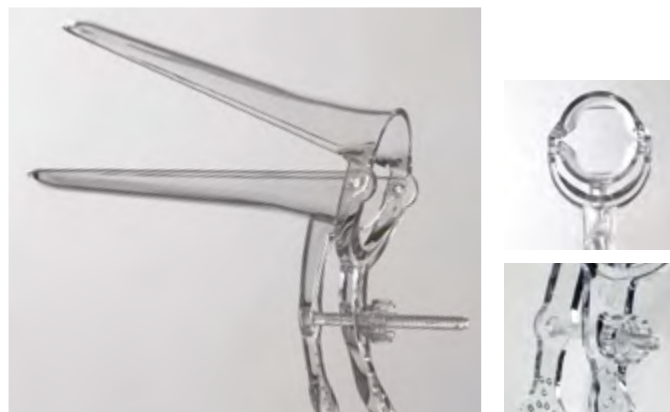

**HCP054** Without Lock - Small 25pk

**HCP055** Without Lock - Medium 25pk

**HCP056** Without Lock - Medium Long 25pk

**HCP059.1** Starter Pack with Lock

**HCP059.3** Starter Pack without Lock

## Parburch Complete 150W Light System

### A comprehensive light system for use with proctoscopes

Complete lighting system with 1.8m long fibre optic cable, variable lighting control and an adapter for all Parburch proctoscopes.



**HCP586** 150W Lighting System with 1.8m Optic Cable

## Disposable Proctoscope

- Singly wrapped in polythene bags, socially clean
- Manufactured from a clear plastic to aid visuals
- Maximum patient comfort is achieved by smooth transition between top of obturator and the end of the proctoscope
- Glossy external finish form comfort
- Single-use designed for general use
- Multiple adapters available



**HCP409** Proctoscope Large - 22mm - 25pk

**HCP410** Proctoscope Medium 20mm - 25pk

**HCP411** Proctoscope Paediatric 12mm - 25pk

## Disposable Proctoscope with Light

Single-use, with built in disposable high powered LED light stem.

- Singly wrapped in polythene bags, socially clean
- Manufactured from a clear plastic to aid visuals
- Maximum patient comfort is achieved by smooth transition between top of obturator and the end of the proctoscope
- Glossy external finish form comfort



**HCP1184** Proctoscope Medium 20mm - 25pk

**HCP1185** Proctoscope Paediatric 12mm - 25pk

**HCP1186** Proctoscope Large 22mm - 25pk

## Universal Speculum

Simple to use unique locking device, effective and noiseless providing a firm hold.

- Pre-lubricated, Smooth, rounded edges and a glossy external finish ensure patient comfort
- Clear plastic instrument based on the standard 'Cuscu' design



**HCP414.1** Speculum Virgin 20mm - 100pk

**HCP414** Speculum Small 24mm - 100pk

**HCP415** Speculum Medium 26mm - 100pk

**HCP416** Speculum Large 30mm - 100pk

**HCP417** Speculum Mixed Pack - (25 of each V-L)

## Sims Dual Sized Vaginal Speculum

- Sold in boxes of 50
- Sterile/Non Sterile
- Single use
- Dual Sized



**HCP1583** Sterile Speculum - 50pk

**HCP1584** Non Sterile Speculum - 50pk

## Parspec Screw Speculum

- **Popular middle screw design**
- Smooth round edges to ensure patient comfort
- Strong, durable, unbreakable plastic material
- Complete with disposable lighting



**HCP1503** Medium with built in Light - 25pk

**HCP1187** Small Screw Speculum - 100pk

**HCP1187** Small Screw Speculum - 100pk

**HCP1188** Medium Screw Speculum - 100pk

## Double Fenestrated Proctoscope

This unique proctoscope has a "Sliding" shutter on one side and a window on the opposite side to give a greater view and examination area.

Instruments can be used at all angles without obstructing the view of the operator. The sliding shutter can be opened to the desired length depending on the nature of the treatment

- Adjustable slide
- Choice of examination area
- Better view of the entire anal canal
- Protects sensitive skin and mucosa with the slide during treatments
- Greater flexibility with many instruments
- Ergonomically stable construction



**HCP1617** DF proctoscope with universal light adapter - 25pk

**HCP1618** DF proctoscope with disposable LED light - 25pk

## Parburch Sponge Holders

These are a multi-purpose Rampley type sponge forcep.

Dimensions: Standard Size 190mm in Length and 70mm from the hinge down.

- Supplied in packs of 25

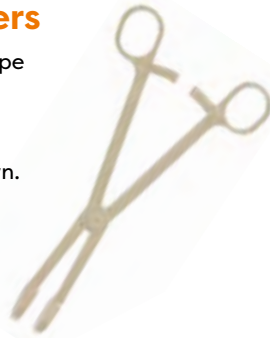

**HCP557** Sterile Sponge Holders (195mm long) - 25pk

## Endometrial Suction Curette

Flexibility of the curette has been made to facilitate adaptation to normal uterine curvature, and provide contact with the wall for improved sample collection.

Dimensions: Total Length 270mm.

- Sold in a box of 100

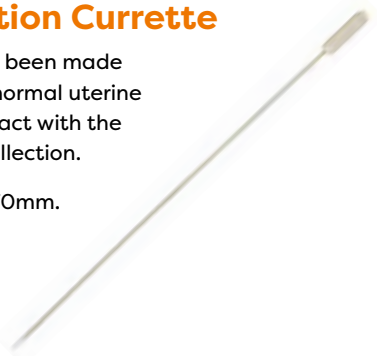

**HCP582** Endometrial Suction Curettes - 100pk

## Pelican Coil Remover

Specifically designed to remove intra-uterine devices and is characterised by an angled tip with a 2:1 tooth combination. The robust design gives the user full control of the instrument and the "V" designed tip ensures a secure grasp of the coil thread to facilitate retrieval of the intra-uterine device.

- Secure locking mechanism
- Angled tip to optimise visibility



**HCP537** Pelican Coil Remover - 50pk

**HCP847** Pelican Coil Remover - 5pk

## Pelican Thread Retriever

Designed to quickly and easily locate lost IUD threads and can also be used to sound the uterus for the presence of the intra-uterine device. Seven specifically designed notches at 10mm intervals (on either side), combined with a long handle, allow for greater control and optimum retrieval of IUD threads.

- Thumb recess for enhanced grip
- Stem with rounded tip to sound the uterus



**HCP536.1** Pelican Thread Retriever - 25pk

## PELJelly

PELJelly is a sterile, water based lubricant designed for use in gynaecological, digital and instrument examinations with no effect on DNA.\* The sachet format allows minimal waste and also removes any concerns regarding cross-infection.

- Convenient Sterile 5g sachet
- Colourless and fragrance free
- 100 pack dispensing carton



\* Givens, M (2008) "Cytology Uncovered! Lubricating Gels – a Personal Experience". *Obs Gynae & Midwifery, News Autumn 2008*, pp. 16-18.

**HCP890** PELJelly - 100pk

## Pelican Tenaculum

A precise single toothed grip with secure locking mechanism, ideal for holding the anterior lip of the cervix during procedures. An alternative choice to practitioners who prefer a single toothed grip over a more evenly spread grip.

- Secure locking mechanism
- Cost effective alternative to metal
- Specifically designed to allow greater visibility of the cervix



**HCP788** Pelican Tenaculum - 50pk

**HCP789** Pelican Tenaculum - 5pk



## Comfispes® Disposable Speculum

The innovative Comfispes® disposable vaginal speculum range offers a range of advantages over similar products:

- 38 degree opening angle provides best access for gynaecology procedures
- Handles are displaced further from the patient
- Textured and frosted handle provides superior grip
- Predictable fail safe feature is outside the patient
- Large skintrap gap for improved patient safety
- Fast acting locking mechanism means shorter procedure durations, less patient trauma

**HCP866** Comfispes® Speculum Small - 25pk

**HCP867** Comfispes® Speculum Medium - 25pk

**HCP868** Comfispes® Speculum Large - 25pk

**HCP869** Comfispes® Speculum Combi Pack (5 Sml, 15 Med, 5 Lrg)



## ComfiSound® Uterine Sound

The ComfiSound is a single-use uterine sound boasting a series of unique features for this latex-free, polyethylene device.

- Moveable rubber cursor and centimetre markings for quick, accurate measurement of the uterus
- Highly flexible Sound adjusts to shape
- Textured handle provides a strong grip for complete confidence
- Easy to hold and manoeuvre
- Latex-Free and Sterile
- Disposable for safety



**HCP1042** Disposable Uterine Sound - 10pk

**HCP1043** Disposable Uterine Sound - 50pk

## ComfiThread® Retrievers

Designed from the outset to simplify the process of retrieving IUCD threads, and make the process more comfortable for patient & practitioner.

- Longer handle ensures the practitioner's hand is kept further from the patient
- Dimpled handle offers excellent practitioner control and grip
- Less obtrusive but equally effective teeth ensure maximum patient comfort

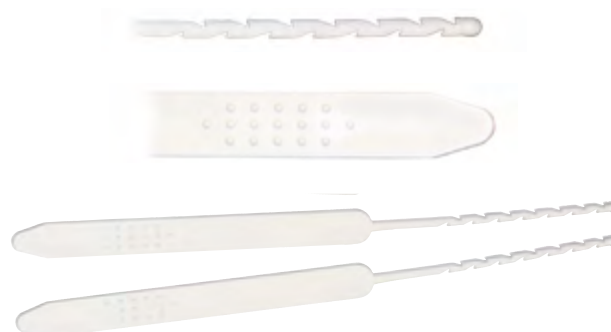

**HCP865** Retrievers - 5pk

## Disposable Uterine Sound

A small, gentle, slim gauge with marking to denote uterine depth prior to insertion of an intra-uterine device

- Single use removes risk of cross contamination
- Sterile, individually packaged
- Good grip and tip control
- Small and slim gauge
- Packaged in packs of 10



**HSU112.2** Sterile - 10pk

## Alere HCG Cassette

**A fast and accurate system for the qualitative detection of hCG in urine with results returned within 5 minutes**

- Sensitive to 25mIU/ml hCG
- Detects pregnancy from the first day of the first missed period and helps detect ectopic pregnancy
- Fast, accurate, reliable results in only 5 minutes
- Built-in procedural control



**BCH017** Alere HCG Cassette

## Ensignia Two/Three Section

Medi **Plinth**

### Two or Three section couches

Medi-Plinth's entry level couch provides great value with strength, elegance and reliability.

Offering a robust platform for medical procedures, this simple couch provides ease of patient transportation while maintaining patient comfort.

This couch offer Medi-Plinth's quality plinth designs at a more competitive price point.

- 260kg safe working load
- 100mm diameter rubber braked transportation castors
- Paper roll holder fitted as standard
- Gas spring assisted back & foot sections as standard
- Low entry height: Ideal for wheelchair transfers
- Industry leading Linak 'High Reliability' actuators
- Manufactured in the UK and CE Marked

### Specification:

- Length: 186cm
- Width: 63cm
- Head/Foot Adjustment: -20° to +85°
- Height Max: 91cm
- Height Min: 46cm



### Warranty:

These robustly constructed products will operate for many years with little attention, an annual service is advised.

We offer a comprehensive parts and labour warranty to cover manufacturing or material defects of **seven years for the frame and three years for moving parts.**

**E2** Ensignia Two Section Plinth

**E3** Ensignia Three Section Plinth

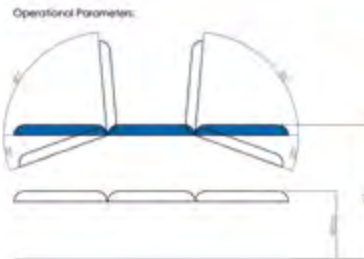
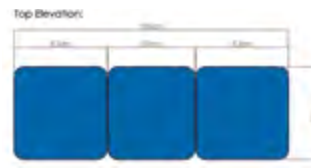
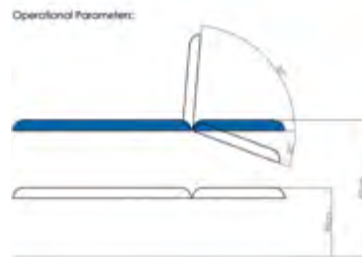

### MRSA resistant anti bacterial & fire retardant vinyl colours:

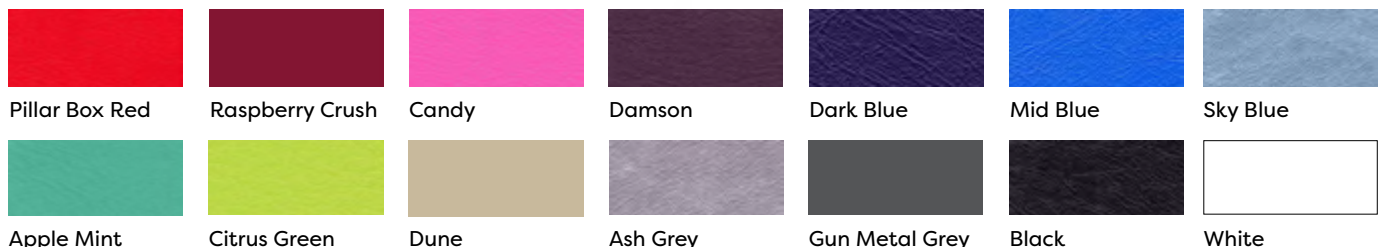

## Two/Three Section Plinths

### Two or Three section couches

Medi-Plinth's standard format plinths provide exceptional value whilst offering strength, elegance and the reliability you have come to expect. Presenting a robust platform for a range of medical procedures, providing long-lasting ease of use whilst also maintaining optimum patient comfort.

- 260kg safe working load for electric versions
- 225kg safe working load for hydraulic versions
- Paper roll holder fitted as standard
- Retractable castors enable plinth to be easily moved
- Adjustable foot for stability on uneven floors
- Gas spring assisted back & foot sections as standard
- Low entry height: Ideal for wheelchair transfers
- Industry leading Linak 'High Reliability' actuators
- Manufactured in the UK and CE Marked

### Specification:

- Length: 186cm
- Width: 63cm
- Head/Foot Adjustment: -20° to +85°
- Height: 46-91cm

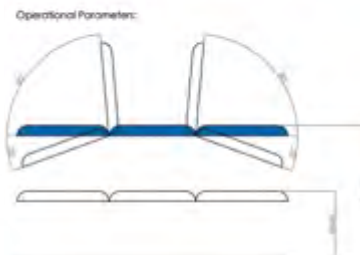
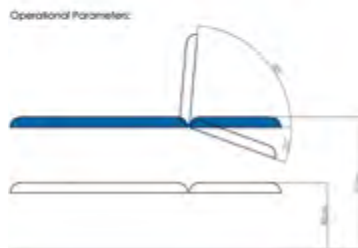

### MRSA resistant anti bacterial & fire retardant vinyl colours:

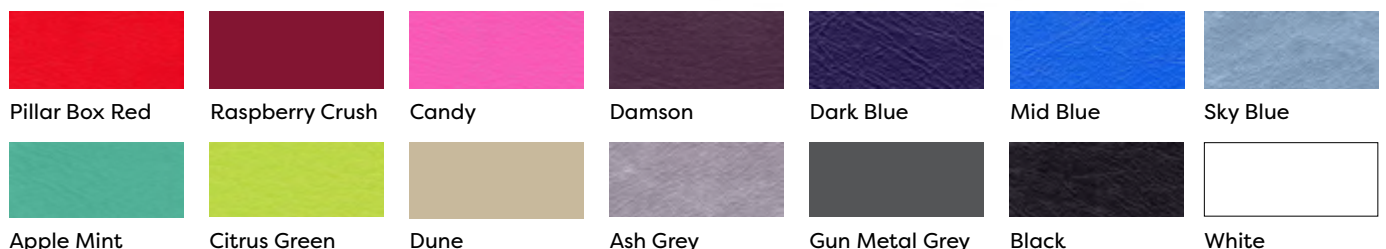

# Medi Plinth



### Warranty:

These robustly constructed products will operate for many years with little attention, an annual service is advised.

We offer a comprehensive parts and labour warranty to cover manufacturing or material defects of **seven years for the frame and three years for moving parts.**

<b>BA02H</b>	Two Section Plinth - Hydraulic
<b>BA02E</b>	Two Section Plinth - Electric
<b>BA02E+EB01</b>	Three Section Plinth - Electric with Electric Back
<b>BA03H</b>	Three Section Plinth - Hydraulic
<b>BA03E</b>	Three Section Plinth - Electric
<b>BA03E+EB01</b>	Three Section Plinth - Electric with Electric Back
<b>BA03E+EB03</b>	Three Section Plinth - Electric with Electric Foot
<b>BA03E+EB02</b>	Three Section Tilting - Electric
<b>BA03E+EB05</b>	Three Section Tilting - Electric with Electric Back & Foot

## Bariatric Wide Couches

Medi-Plinth have designed this range of Electric lifting plinths that combine a safe working/lifting capacity of up to 320kg

With extra wide-upholstery for maximum comfort, choose from 75 or 100cm width. Available with drop-end foot section.

- **Bariatric arm rests are not included as standard\***
- 320kg safe working load
- Electric backrest adjustment included as standard
- Heavy-duty adjustable foot for stability on uneven floors
- Low entry height: Ideal for wheelchair transfers
- Industry leading Linak 'High Reliability' actuators
- Manufactured in the UK and CE Marked

### Specification:

- Length: 186cm
- Width: 75-100cm
- Head/Foot Adjustment: -20° to +85°
- Drop-end Foot Section: -85° (Optional addition)
- Height: 50-95cm

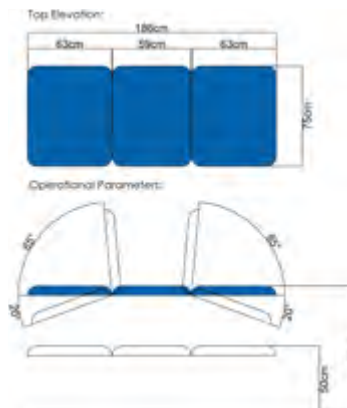
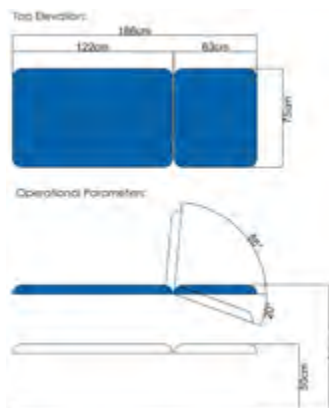

\*Arm rests shown are an optional accessory



\*Arm rests shown are an optional accessory

### MRSA resistant anti bacterial & fire retardant vinyl colours:

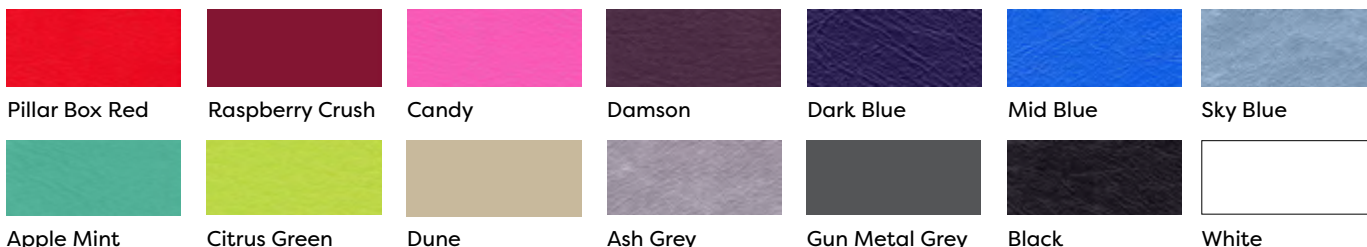

### Warranty:

These robustly constructed products will operate for many years with little attention, an annual service is advised.

We offer a comprehensive parts and labour warranty to cover manufacturing or material defects of **seven years for the frame and three years for moving parts.**

**BARIO2100** Two Section Bariatric - 100cm Width

**BARIO275** Two Section Bariatric - 75cm Width

**BARIO3100** Three Section Bariatric - 100cm Width

**BARIO375** Three Section Bariatric - 75cm Width

**BARIO3100DE** Three Section Bariatric Drop-End - 100cm Width

**BARIO375DE** Three Section Bariatric Drop-End - 75cm Width

## Changing Table

Our single-section changing table is ideal for use in the care of disabled or dependent people. Offering a secure, height adjustable platform suitable for transferring patients to/from wheelchairs or portable commodes.

Available in a variety of lengths designed to provide a comfortable plinth for all patient ages and requirements.

- **Painted-padded cotsides are not included as standard\***
- 260kg safe working load for electric versions
- 225kg safe working load for hydraulic versions
- Retractable castors enable plinth to be easily moved
- Adjustable foot for stability on uneven floors
- Low entry height: Ideal for wheelchair transfers
- Industry leading Linak 'High Reliability' actuators
- Manufactured in the UK and CE Marked

### Specification:

- Lengths: 100cm, 120cm, 150cm or 180cm
- Width: 63cm
- Height Max: 91cm
- Height Min: 46cm

Top Elevator:



Operational Parameters:



### Warranty:

These robustly constructed products will operate for many years with little attention, an annual service is advised.

We offer a comprehensive parts and labour warranty to cover manufacturing or material defects of **seven years for the frame and three years for moving parts.**

**Medi Plinth**



**BA01H1000** Changing Table Hydraulic - 1000mm

**BA01E1000** Changing Table Electric - 1000mm

**BA01H1200** Changing Table Hydraulic - 1200mm

**BA01E1200** Changing Table Electric - 1200mm

**BA01H1500** Changing Table Hydraulic - 1500mm

**BA01E1500** Changing Table Electric - 1500mm

**BA01H1800** Changing Table Hydraulic - 1800mm

**BA01E1800** Changing Table Electric - 1800mm

### MRSA resistant anti bacterial & fire retardant vinyl colours:

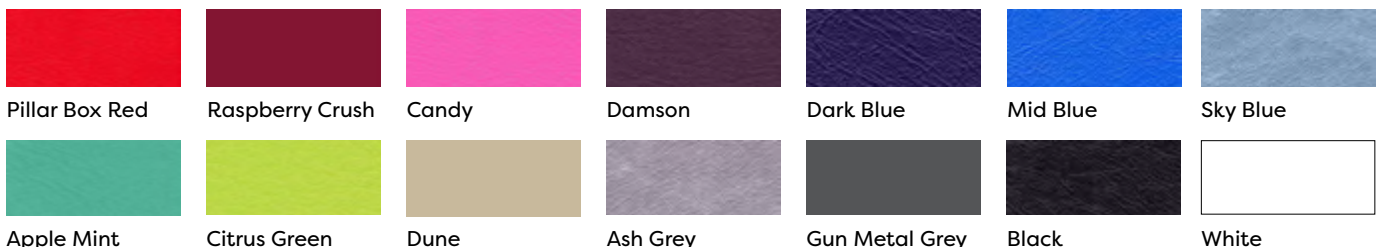

## GP Gynaecological Plinth

Features improved access and ergonomics for the clinician combined with enhanced comfort and dignity for the patient. Capable of use as a standard two section plinth when required.

Effortless adjustment via electric motors for height and seat tilt, enabling Trendelenburg to 15°.

- 260kg safe working load
- Includes a stainless steel instrument tray and accessory rail with pair of indexing clamps as standard
- Retractable castors enable plinth to be easily moved
- Adjustable foot for stability on uneven floors
- Low entry height: Ideal for wheelchair transfers
- Industry leading Linak 'High Reliability' actuators
- Manufactured in the UK and CE Marked

### Specification:

- Length: 173cm
- Width: 63cm
- Height: 50-95cm
- Head/Foot Adjustment: -20° to +85°

Top Elevation:



Operational Parameters:

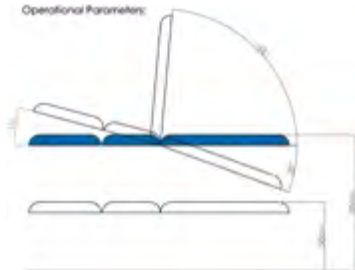

GY02ET

### MRSA resistant anti bacterial & fire retardant vinyl colours:

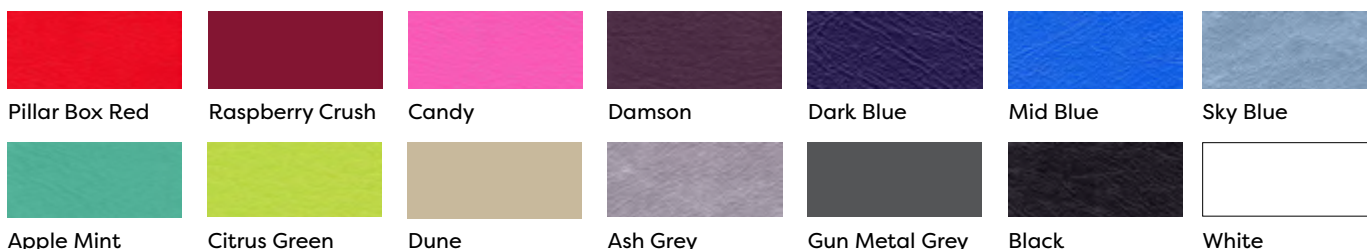

Medi Plinth



Made in the UK



Free Delivery

### Warranty:

These robustly constructed products will operate for many years with little attention, an annual service is advised.

We offer a comprehensive parts and labour warranty to cover manufacturing or material defects of **seven years for the frame and three years for moving parts.**

**GY02ES** GP Gynae with Stirrups - Electric

**GY02ES+EB01** GP Gynae with Stirrups - Electric with Electric Back

**GY02ET** GP Gynae with Troughs - Electric

**GY02ET+EB01** GP Gynae with Troughs - Electric with Electric Back

**GY02EF** GP Gynae with Foot Pads - Electric

**GY02EF+EB01** GP Gynae with Foot Pads - Electric with Electric Back

## Ultra Gynaecology Plinth

For more comprehensive control of patient positioning, the Ultra Gynae couch combines three electric motors, offering individual control of height, tilt and backrest angle. Offering an increased height for clinician ergonomics and Trendelenburg to 20°.

- 260kg safe working load
- Includes a stainless steel instrument tray as standard
- Lithotomy recess for clinician access
- Retractable castors enable plinth to be easily moved
- Adjustable foot for stability on uneven floors
- Low entry height: Ideal for wheelchair transfers
- Industry leading Linak 'High Reliability' actuators
- Manufactured in the UK and CE Marked

### Specification:

- Length: 184cm
- Width: 63cm
- Height: 60-105cm
- Head/Foot Adjustment: -20° to +85°

Top Elevation:



Operational Parameters:

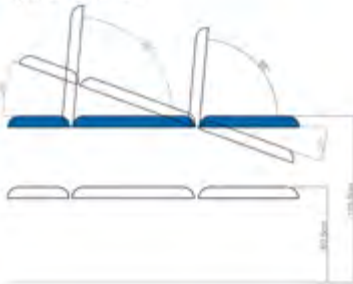

GY04ET

### Warranty:

These robustly constructed products will operate for many years with little attention, an annual service is advised.

We offer a comprehensive parts and labour warranty to cover manufacturing or material defects of **seven years for the frame and three years for moving parts.**

Medi Plinth



Made in the UK



Free Delivery

**GY04ES** Ultra Gynae with stirrups - Electric

**GY04ES+EB01** Ultra Gynae with stirrups - Electric with Electric Back

**GY04ET** Ultra Gynae with troughs - Electric

**GY04ET+EB01** Ultra Gynae with troughs - Electric with Electric Back

**GY04EF** Ultra Gynae with foot pads - Electric

**GY04EF+EB01** Ultra Gynae with foot pads - Electric with Electric Back

### MRSA resistant anti bacterial & fire retardant vinyl colours:



Pillar Box Red



Raspberry Crush



Candy



Damson



Dark Blue



Mid Blue



Sky Blue



Apple Mint



Citrus Green



Dune



Ash Grey



Gun Metal Grey



Black



White

## Single Column Medical Chair

Our electrically operated column chair offering all of the functionality of traditional examination chairs, whilst including new premium features, such as its compact size and base cover for ease of cleaning.

Suitable for environments where space is at a premium with its smaller footprint, the chair is available with a range of accessories as required to facilitate a wide variety of medical procedures.

- 190kg safe working load
- This compact design is very favourable when space is limited
- Electric back section and gas foot section as standard
- Adjustable padded headrest
- Retractable castors enable plinth to be easily moved
- Adjustable foot for stability on uneven floors
- Low entry height: Ideal for wheelchair transfers
- Industry leading Linak 'High Reliability' actuators
- Manufactured in the UK and CE Marked

### Specification:

- Length: 169cm
- Width: 63cm
- Height: 46-86cm
- Tilting Seat Trendelenburg: 15°
- Head/Foot Adjustment: -15° to +85°

### Warranty:

These robustly constructed products will operate for many years with little attention, an annual service is advised.

We offer a comprehensive parts and labour warranty to cover manufacturing or material defects of **seven years for the frame and three years for moving parts.**

Medi Plinth



**MED04EC** Single Column Medical Chair - Electric

**MED04ECT** Single Column Medical Chair - Electric Tilting

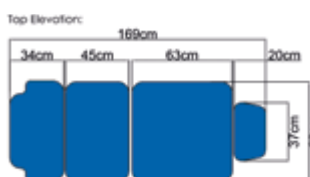

Operational Parameters:

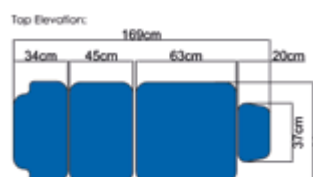
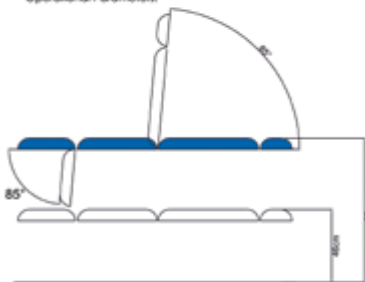

Operational Parameters:

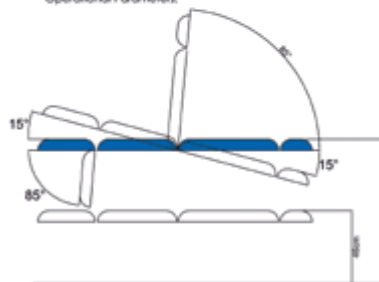

### MRSA resistant anti bacterial & fire retardant vinyl colours:

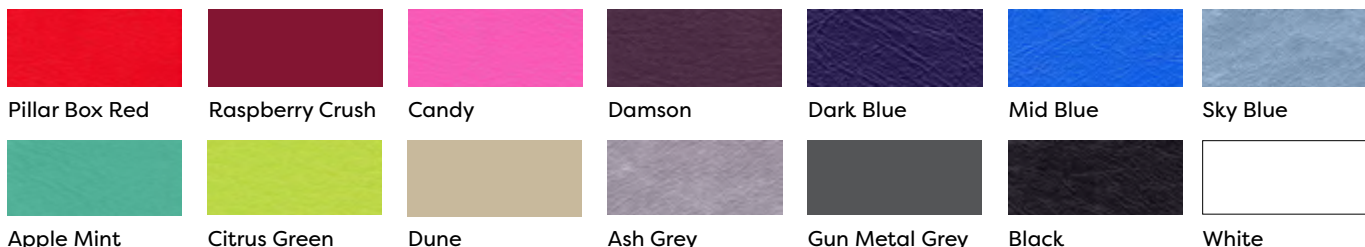



## Multi Purpose Plinth

Our multi purpose plinth is an all-in-one option designed to facilitate a modern-day practice

Specifically created to be suitable for numerous procedures including phlebotomy, minor surgery, gynaecology and general examination.

This four-in-one plinth has a foot section dropping to 85° allowing it to easily fit into the smallest room with patients sat in a chair position.

- 260kg safe working load for electric versions
- 225kg safe working load for hydraulic versions
- Supplied with one phlebotomy arm, two gynaecology stirrups and a quick-release treatment table as standard
- Retractable castors enable plinth to be easily moved
- Adjustable foot for stability on uneven floors
- Gas spring assisted back & foot sections as standard
- Low entry height: Ideal for wheelchair transfers
- Industry leading Linak 'High Reliability' actuators
- Manufactured in the UK and CE Marked

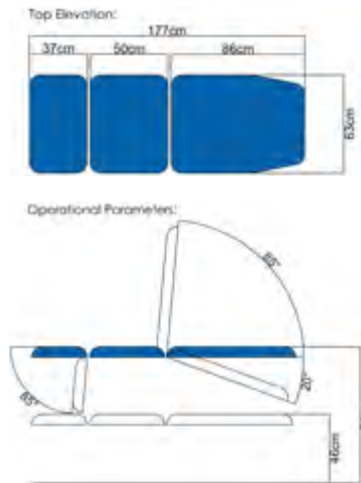

### Specification:

- Length: 177cm
- Width: 63cm
- Height: 46-91cm
- Head/Foot Adjustment: -20° to +85°

**Medi Plinth**



### Warranty:

These robustly constructed products will operate for many years with little attention, an annual service is advised.

We offer a comprehensive parts and labour warranty to cover manufacturing or material defects of **seven years for the frame and three years for moving parts.**

**MP03H** Multi Purpose Plinth - Hydraulic

**MP03E** Multi Purpose Plinth - Electric

**MP03E+EB01** Multi-Purpose Plinth - Electric with Electric Back

**MP03E+EB02** Multi-Purpose Tilting Plinth - Electric

**MP03E+EB06** Multi-Purpose Tilting Plinth - Electric with Electric Back

### MRSA resistant anti bacterial & fire retardant vinyl colours:

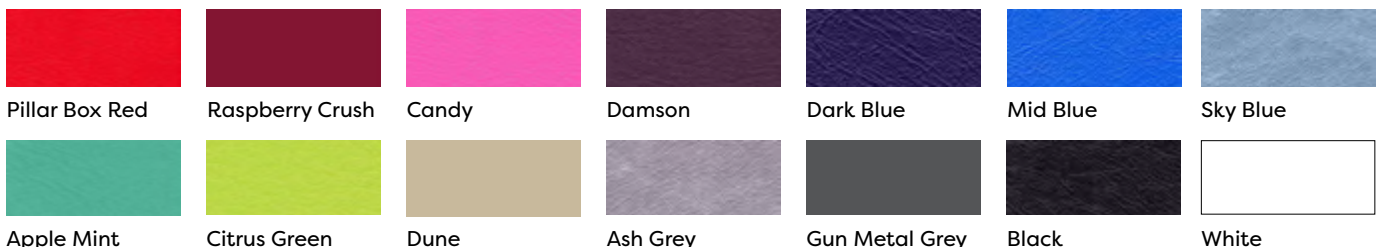

## Podiatry Chair

Medi-Plinth's podiatry chair has been designed with a focus on improved patient comfort, this chair includes adjustable armrests and a back section that reaches head height.

In addition, the mid section on the tilting podiatry tilts to create a very natural seated position with the knees raised, whilst providing a better position for the practitioner.

- 260kg safe working load
- Includes adjustable armrests as standard
- Split leg design for individual adjustment of each leg section
- Each leg includes extending foot rests
- Gas spring assisted back & foot sections
- Retractable castors enable plinth to be easily moved
- Adjustable foot for stability on uneven floors
- Low entry height: Ideal for wheelchair transfers
- Industry leading Linak 'High Reliability' actuators
- Manufactured in the UK and CE Marked

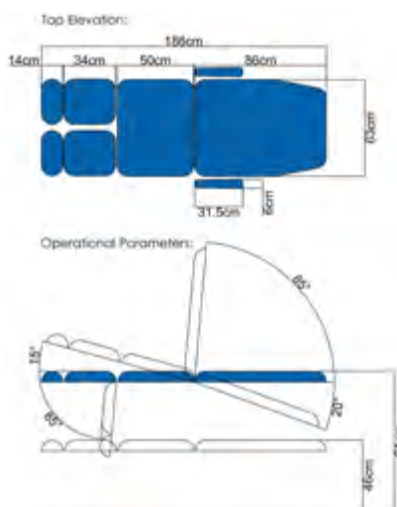

### Specification:

- Length: 186cm
- Width: 63cm
- Head/Foot Adjustment: -20° to +80°
- Height: 40-90cm

Medi Plinth



### Warranty:

These robustly constructed products will operate for many years with little attention, an annual service is advised.

We offer a comprehensive parts and labour warranty to cover manufacturing or material defects of **seven years for the frame and three years for moving parts.**

**BAC06E** Podiatry Chair - Electric

**BAC06E+EB01** Podiatry Chair - Electric with Electric Back

**BTC06E** Podiatry Chair Tilting - Electric

**BTC06E+EB01** Podiatry Chair Tilting - Electric with Electric Back



\*MAG light shown is an optional accessory - See 'Lighting' category

### MRSA resistant anti bacterial & fire retardant vinyl colours:

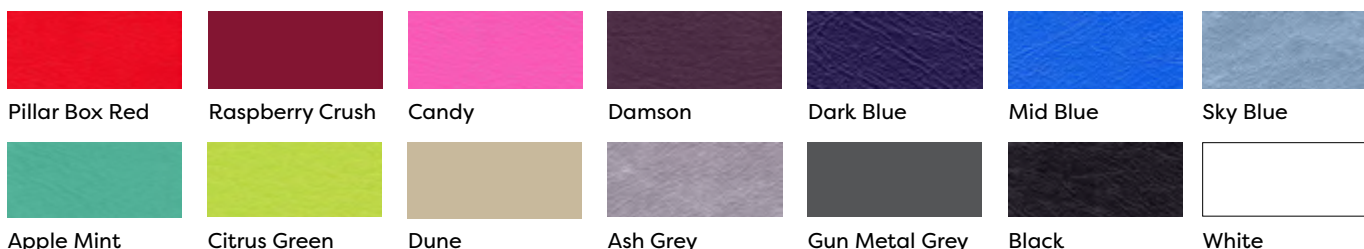

# Outpatients Plinth

## Two or Three section plinths

The Medi-Plinth outpatients plinth has been designed to enable examination/treatment and transportation within a medical department.

Patient safety is enhanced with the addition of chrome cot sides fitted as standard on these plinths.

- 260kg safe working load for electric versions
- 225kg safe working load for hydraulic versions
- Chrome cotsides included as standard
- 100mm individually braked transportation castors
- Battery operation system (electric versions)
- Gas spring assisted back & foot sections as standard
- Low entry height: Ideal for wheelchair transfers
- Industry leading Linak 'High Reliability' actuators
- Manufactured in the UK and CE Marked

### Specification:

- Length: 186cm
- Width: 63cm
- Head/Foot Adjustment: -20° to +85°
- Height: 46-91cm

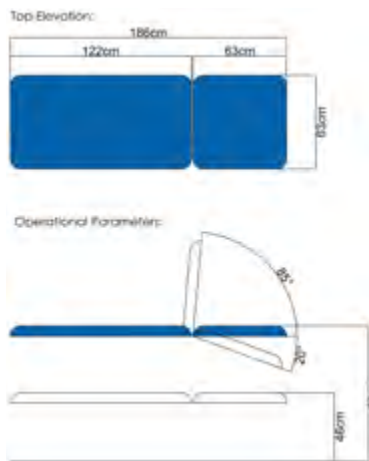

### Warranty:

These robustly constructed products will operate for many years with little attention, an annual service is advised.

We offer a comprehensive parts and labour warranty to cover manufacturing or material defects of **seven years for the frame and three years for moving parts.**



<b>OP02H</b>	Two Section - Hydraulic
<b>OP02E</b>	Two Section - Electric
<b>OP02E+EB01</b>	Two Section - Electric with Electric Back
<b>OP02E+EB03</b>	Two Section - Electric with Electric Foot
<b>OP02E+EB07</b>	Two Section - Electric with Electric Back & Foot
<b>OP03H</b>	Three Section - Hydraulic
<b>OP03E</b>	Three Section - Electric
<b>OP03E+EB01</b>	Three Section - Electric with Electric Back
<b>OP03E+EB03</b>	Three Section - Electric with Electric Foot
<b>OP03E+EB07</b>	Three Section - Electric with Electric Back & Foot

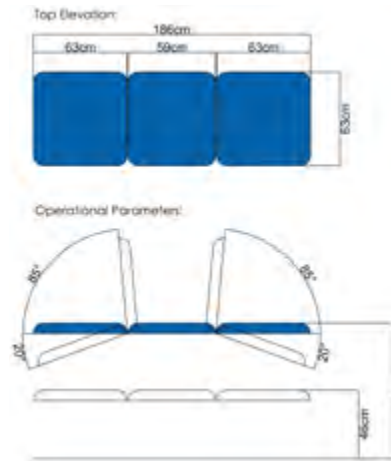

### MRSA resistant anti bacterial & fire retardant vinyl colours:

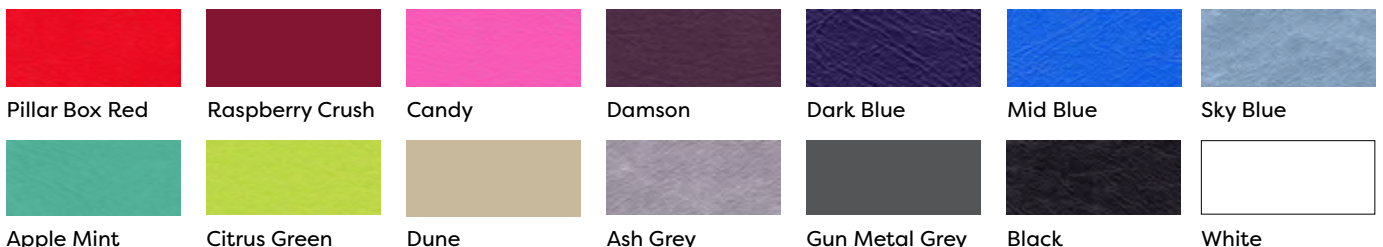

## Treatment/Plaster Chair

### Single or split leg chairs

With a unique and innovative design, this chair is the ideal option when specialist treatments are required. Ideal for minor surgery or plaster application.

The removable side tables provide a smooth, stable and easily cleaned surface to work on. These can be dropped down out of the way, with a quick release mechanism when not required.

- 260kg safe working load for electric versions
- 225kg safe working load for hydraulic versions
- Two quick-release treatment tables included as standard
- Retractable castors enable plinth to be easily moved
- Adjustable foot for stability on uneven floors
- Gas spring assisted back & foot sections as standard
- Low entry height: Ideal for wheelchair transfers
- Industry leading Linak 'High Reliability' actuators
- Manufactured in the UK and CE Marked

### Specification:

- Length: 186cm
- Width: 63cm
- Head/Foot Adjustment: -20° to +85°
- Height: 46-91cm

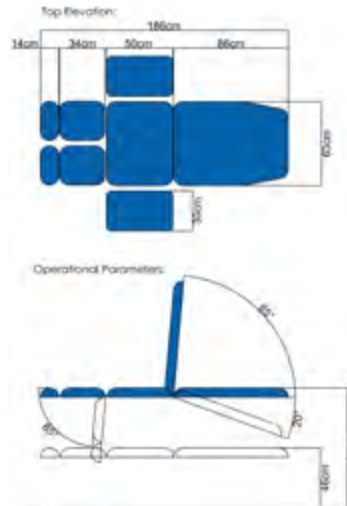

**Medi Plinth**



### Warranty:

These robustly constructed products will operate for many years with little attention, an annual service is advised.

We offer a comprehensive parts and labour warranty to cover manufacturing or material defects of **seven years for the frame and three years for moving parts.**

<b>PL01H</b>	T/P Chair Split Leg - Hydraulic
<b>PL01E</b>	T/P Chair Split Leg - Electric
<b>PL01E+EB01</b>	T/P Chair Split Leg - Electric with Electric Back
<b>PL01E+EB02</b>	T/P Chair Split Leg Tilting - Electric
<b>PL01E+EB06</b>	T/P Chair Split Leg Tilting - Electric with Electric Back
<b>PL02H</b>	T/P Chair Single Leg - Hydraulic
<b>PL02E</b>	T/P Chair Single Leg - Electric
<b>PL02E+EB01</b>	T/P Chair Single Leg - Electric with Electric Back
<b>PL02E+EB02</b>	T/P Chair Single Leg Tilting - Electric
<b>PL02E+EB06</b>	T/P Chair Single Leg Tilting - Electric with Electric Back

### MRSA resistant anti bacterial & fire retardant vinyl colours:

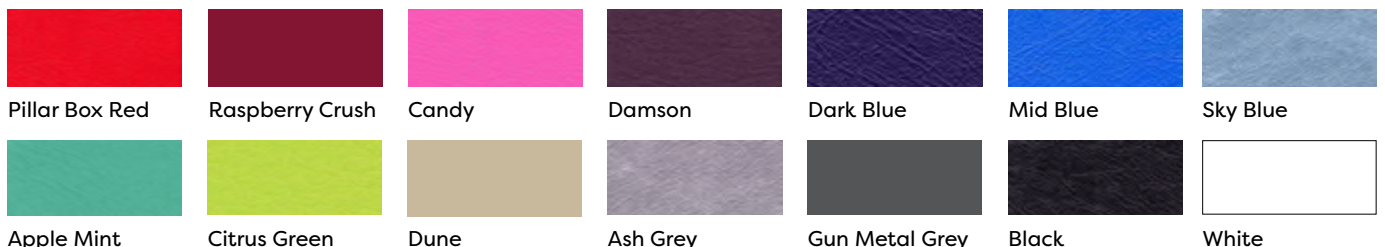

# Phlebotomy Chair

## Single or split leg chairs

The Medi-Plinth phlebotomy chair offers improved patient comfort combined with easy access for the phlebotomist, this variable height chair comes with two fully adjustable armrests and split/single leg as required.

The chair is designed to be versatile and is also capable of use as a standard three section examination couch.

- 260kg safe working load for electric versions
- 225kg safe working load for hydraulic versions
- Fully adjustable ergonomic padded arm supports
- Retractable castors enable plinth to be easily moved
- Adjustable foot for stability on uneven floors
- Gas spring assisted back & foot sections as standard
- Low entry height: Ideal for wheelchair transfers
- Industry leading Linak 'High Reliability' actuators
- Manufactured in the UK and CE Marked

### Specification:

- Length: 186cm
- Width: 63cm
- Head/Foot Adjustment: -20° to +85°
- Height: 46-91cm

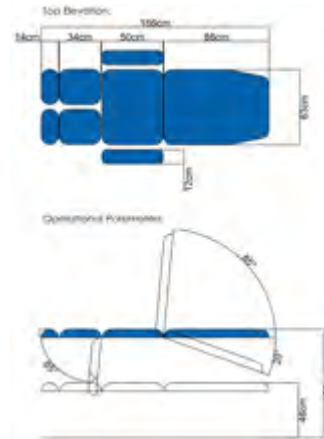
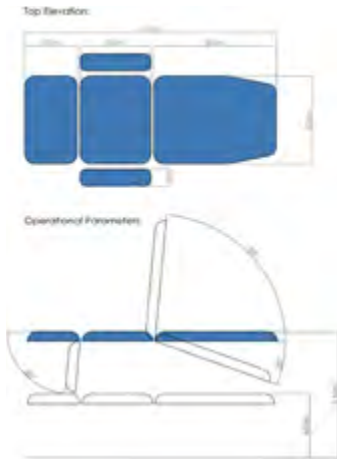

### MRSA resistant anti bacterial & fire retardant vinyl colours:

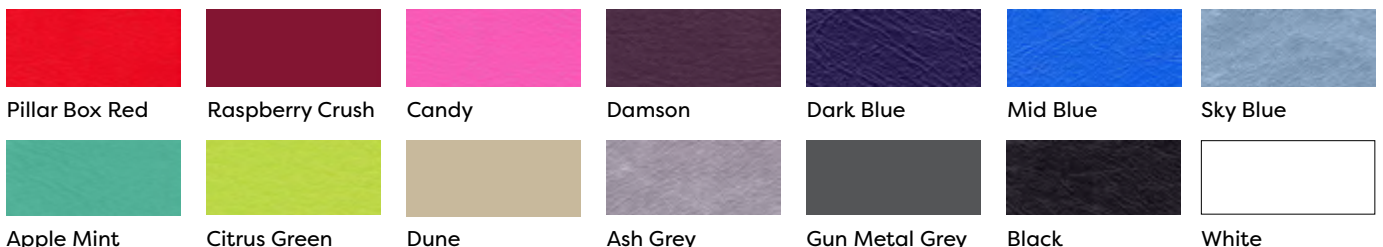

### Warranty:

These robustly constructed products will operate for many years with little attention, an annual service is advised.

We offer a comprehensive parts and labour warranty to cover manufacturing or material defects of **seven years for the frame and three years for moving parts.**



<b>PH02H</b>	Phlebot. Chair Single Leg - Hydraulic
<b>PH02E</b>	Phlebot. Chair Single Leg - Electric
<b>PH02E+EB01</b>	Phlebot. Chair Single leg - Electric with Electric Back
<b>PH02E+EB02</b>	Phlebot. Chair Single Leg Tilting - Electric
<b>PH02E+EB06</b>	Phlebot. Chair Single Leg Tilting - Electric with Electric Back
<b>PH01H</b>	Phlebot. Chair Split Leg - Hydraulic
<b>PH01E</b>	Phlebot. Chair Split Leg - Electric
<b>PH01E+EB01</b>	Phlebot. Chair Split Leg - Electric with Electric Back
<b>PH01E+EB02</b>	Phlebot. Chair Split Leg Tilting - Electric
<b>PH01E+EB06</b>	Phlebot. Chair Split Leg Tilting - Electric with Electric Back

## Drop End Three Section Plinth

Designed to make optimum use of small spaces, the plinth can be used as a traditional three section couch or adjusted into a medical chair. This enables patients to sit from the front or side and when fitted with optional accessories, can be used for a wide range of gynaecological and other procedures.

- 260kg safe working load for electric versions
- 225kg safe working load for hydraulic versions
- Retractable castors enable plinth to be easily moved
- Adjustable foot for stability on uneven floors
- Gas spring assisted back & foot sections as standard
- Low entry height: Ideal for wheelchair transfers
- Industry leading Linak 'High Reliability' actuators
- Manufactured in the UK and CE Marked

### Specification:

- Length: 177cm
- Width: 63cm
- Head/Foot Adjustment: -20° to +85°
- Height: 46-91cm

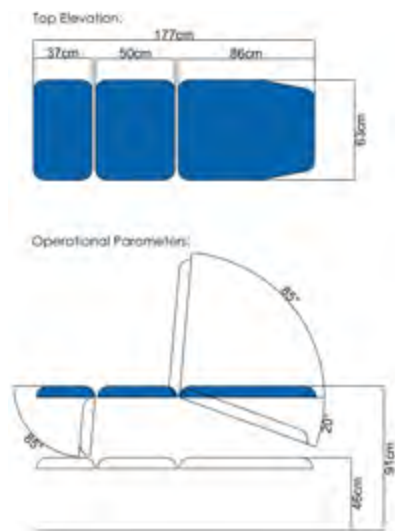

### Warranty:

These robustly constructed products will operate for many years with little attention, an annual service is advised.

We offer a comprehensive parts and labour warranty to cover manufacturing or material defects of **seven years for the frame and three years for moving parts.**



<b>DE03H</b>	Drop End Three Section Plinth - Hydraulic
<b>DE03E</b>	Drop End Three Section Plinth - Electric
<b>DE03E+EB01</b>	Drop End Three Section Plinth - Electric with Electric Back
<b>DE03E+EB02</b>	Drop End Three Section Tilting - Electric
<b>DE03E+EB06</b>	Drop End Three Section Tilting - Electric with Electric Back

### MRSA resistant anti bacterial & fire retardant vinyl colours:

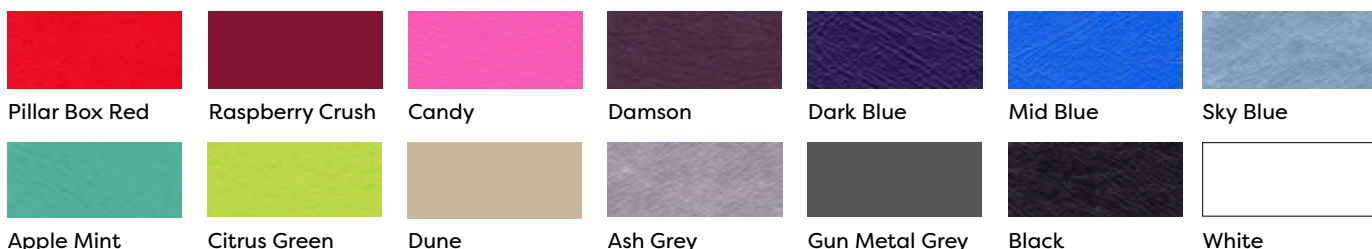

## Echocardiography Plinth

The extended mid section provides comfortable seating, while the shaped backrest provides clinicians improved access to the patient. The padded support handles allow for patients to comfortably lie towards the edge of the couch with confidence.

- 260kg safe working load
- Two patient steadying handles, for use at either side
- Extending operator seat section that can be fitted either side
- Retractable castors enable plinth to be easily moved
- Adjustable foot for stability on uneven floors
- Gas spring assisted back & foot sections as standard
- Low entry height: Ideal for wheelchair transfers
- Industry leading Linak 'High Reliability' actuators
- Manufactured in the UK and CE Marked

### Specification:

- Length: 205cm
- Width: 63/74cm
- Head/Foot Adjustment: -20° to +85°
- Height: 46-91cm

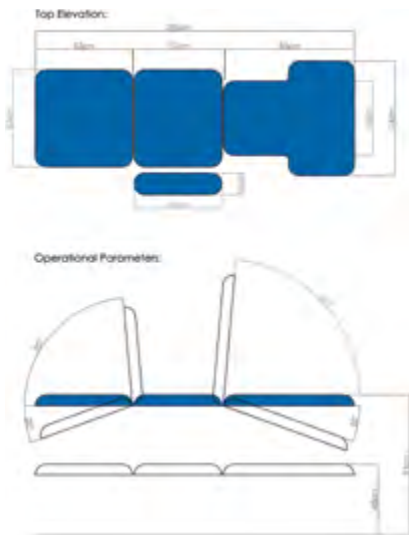

### Warranty:

These robustly constructed products will operate for many years with little attention, an annual service is advised.

We offer a comprehensive parts and labour warranty to cover manufacturing or material defects of **seven years for the frame and three years for moving parts.**

**Medi Plinth**



<b>ECG03E</b>	ECG Plinth - Electric
<b>ECG03E+EB01</b>	ECG Plinth - Electric with Electric Back
<b>ECG03E+EB07</b>	ECG Plinth - Electric with Electric Back & Foot
<b>ECG03T</b>	ECG Tilting Plinth - Electric
<b>ECG03T+EB01</b>	ECG Tilting Plinth - Electric with Electric Back
<b>ECG03T+EB07</b>	ECG Tilting Plinth - Electric with Electric Back & Foot



### MRSA resistant anti bacterial & fire retardant vinyl colours:

Pillar Box Red	Raspberry Crush	Candy	Damson	Dark Blue	Mid Blue	Sky Blue
Apple Mint	Citrus Green	Dune	Ash Grey	Gun Metal Grey	Black	White

## Two Section Bo Plinth - Electric

Medi-Plinth's 2 Section Bo-Plinth is ideal for treating heavier patients with neurological conditions and head injuries. Its sturdy wide top makes the couch safe for the therapist to treat the patient with both ease and comfort in mind.

- **Cotsides are shown but not included as standard**
- 320kg safe working load
- Dual gas spring assisted back section
- Retractable castors enable plinth to be easily moved
- Adjustable foot for stability on uneven floors
- Low entry height: Ideal for wheelchair transfers
- Industry leading Linak 'High Reliability' actuators
- Manufactured in the UK and CE Marked

### Specification:

- Length: 190cm
- Width: 102cm
- Head Adjustment: +80°
- Height: 40-90cm

### Warranty:

These robustly constructed products will operate for many years with little attention, an annual service is advised.

We offer a comprehensive parts and labour warranty to cover manufacturing or material defects of **seven years for the frame and three years for moving parts.**

**B001E** Two Section Bo Plinth - Electric



Medi Plinth



Made in the UK



Free Delivery

## Ultrasound Couch

Medi-Plinth's ultrasound couch provides smooth and effortless patient positioning with electric variable height, gas spring assisted back and leg sections plus electric tilt providing Trendelenburg facility.

- 260kg safe working load
- Electric tilt facility to allow for Trendelenburg positioning
- Gas spring assisted back & foot sections
- Retractable castors enable plinth to be easily moved
- Adjustable foot for stability on uneven floors
- Low entry height: Ideal for wheelchair transfers
- Industry leading Linak 'High Reliability' actuators
- Manufactured in the UK and CE Marked

### Specification:

- Length: 177cm
- Width: 63cm
- Head/Foot Adjustment: -20° to +85°
- Trendelendburg: 15°
- Height: 46-91cm

### Warranty:

These robustly constructed products will operate for many years with little attention, an annual service is advised.

We offer a comprehensive parts and labour warranty to cover manufacturing or material defects of **seven years for the frame and three years for moving parts.**

**US03TE** Ultrasound Tilting - Electric

**US03TE+EB01** Ultrasound Tilting - Electric with Electric Back

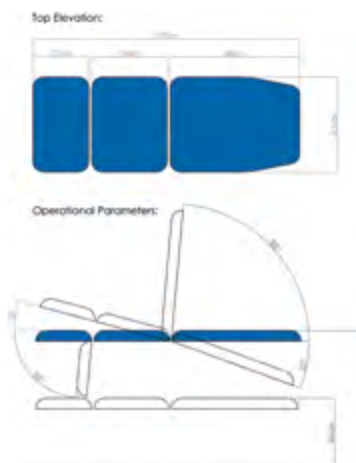

Medi Plinth



Made in the UK



Free Delivery



## Medical Chair

Focusing on combining efficient care with patient comfort, while providing a stable work surface for patient examination. Available with tilting seat to create a natural seated position with the knees slightly raised.

- 260kg safe working load
- Each leg section includes extendible footrests
- Gas spring assisted back & foot sections as standard
- Retractable castors enable plinth to be easily moved
- Adjustable foot for stability on uneven floors
- Low entry height: Ideal for wheelchair transfers
- Industry leading Linak 'High Reliability' actuators
- Manufactured in the UK and CE Marked

### Specification:

- Length: 186cm
- Width: 63cm
- Height: 46-91cm
- Tilting Seat: 15°

### Warranty:

These robustly constructed products will operate for many years with little attention, an annual service is advised.

We offer a comprehensive parts and labour warranty to cover manufacturing or material defects of **seven years for the frame and three years for moving parts.**

**MED06H** Medical Chair - Hydraulic (Non-Tilting)

**MED06E** Medical Chair - Electric (Non-Tilting)

**MEDT06E** Medical Chair - Electric Tilting

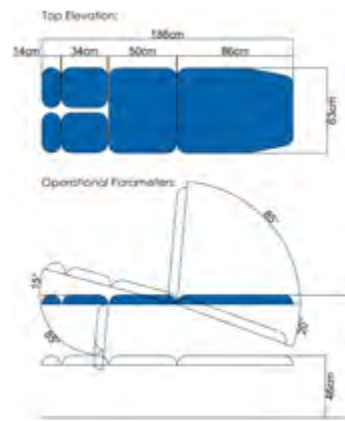

**Medi Plinth**

Made in the UK

Free Delivery

B

Furniture

## Day Care Couch

Ideal for patients that spend long periods seated for treatment or examination. Designed with patient comfort in mind, features a linked castor wheel system for safety and ease of use.

- 260kg safe working load
- Central control brake/lock/steer transportation castors
- Fold down sides to secure patient
- Tilting seat and 15° Trendelenburg positioning
- Gas spring assisted back & foot sections
- Retractable castors enable plinth to be easily moved
- Adjustable foot for stability on uneven floors
- Low entry height: Ideal for wheelchair transfers
- Industry leading Linak 'High Reliability' actuators
- Manufactured in the UK and CE Marked

### Specification:

- Length: 177cm
- Width: 63cm
- Head/Foot Adjustment: -20° to +85°
- Trendelendburg: 15°
- Height: 48-93cm

### Warranty:

These robustly constructed products will operate for many years with little attention, an annual service is advised.

We offer a comprehensive parts and labour warranty to cover manufacturing or material defects of **seven years for the frame and three years for moving parts.**

**DC03E** Day Care Couch Tilting - Electric

**DC03E+EB01** Day Care Couch Tilting - Electric with Electric Back

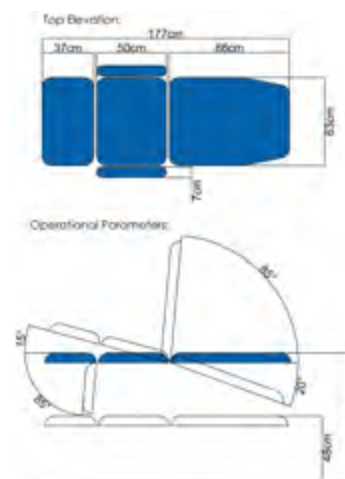

**Medi Plinth**

Made in the UK

Free Delivery

**Medi Plinth**

[www.medi-plinth.co.uk](http://www.medi-plinth.co.uk)



## **PHYSIO+ PLINTH RANGE**

Superior patient positioning

Offering enhanced physiotherapy platforms

## Physio+ Two/ Three Section Plinths

### Two or three section rehabilitation plinths

Medi-Plinth's professional range of highly stable and durable rehabilitation plinths. Utilising the highest quality materials and innovative design to give the clinician a robust platform to work.

Trusted by medical professionals, the Physio+ range offers great clinician access and patient positioning, whilst providing unrivalled reliability. A number of popular options and accessories can be added for versatility and cost effectiveness.

- 260kg safe working load for electric versions
- 225kg safe working load for hydraulic versions
- Paper roll holder fitted as standard
- Anti-entrapment 'Suspa' gas strut operated back/footrests
- Stitched key hole shaped ergonomic breathing hole and bung
- Single Foot switch fitted on electric versions
- Adjustable foot for stability on uneven floors
- Upholstery gusset linking all sections and covering hinge points
- Retractable, easy clean 'Tente' castors
- Precision self-lubricating bearings on all pivot points
- Low entry height: Ideal for wheelchair transfers
- Mobile Hoist clearance beneath base frame
- Industry leading Linak 'High Reliability' actuators
- Manufactured in the UK and CE Marked

**Medi Plinth**



### Specification:

- Length: 186cm
- Width: 63cm
- Head/Foot Adjustment: -20° to +80°
- Height Max: 91cm
- Height Min: 46cm

### Warranty:

These robustly constructed products will operate for many years with little attention, an annual service is advised.

We offer a comprehensive parts and labour warranty to cover manufacturing or material defects of **seven years for the frame and three years for moving parts.**

**PHYS+02H** Physio+ Two Section Plinth - Hydraulic

**PHYS+02E** Physio+ Two Section Plinth - Electric

**PHYS+02E+EB01** Physio+ Two Section Plinth - Electric with Electric Back

**PHYS+03H** Physio+ Three Section Plinth - Hydraulic

**PHYS+03E** Physio+ Three Section Plinth - Electric

**PHYS+03E+EB01** Physio+ Three Section Plinth - Electric with Electric Back

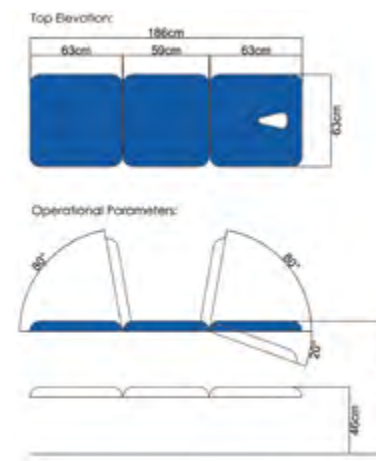
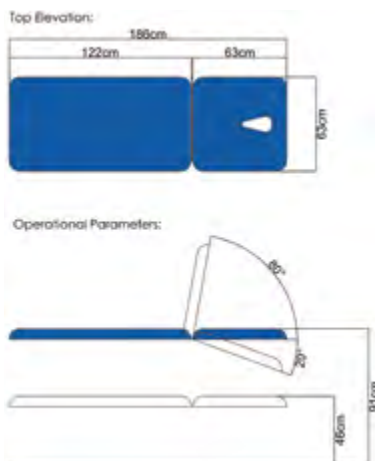

### MRSA resistant anti bacterial & fire retardant vinyl colours:

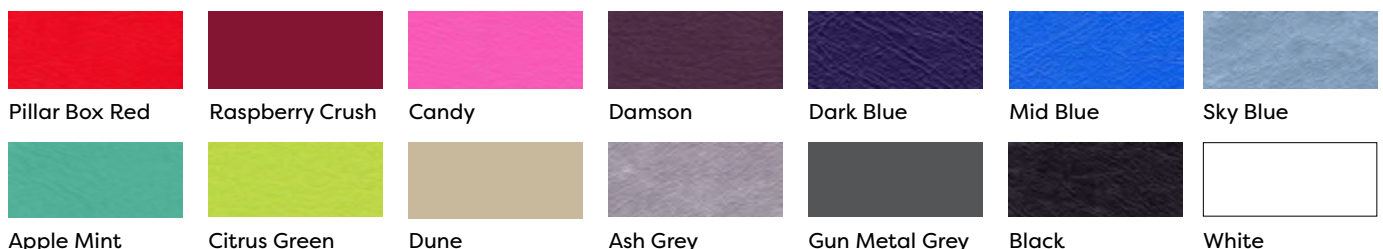

## Physio+ Four/Five Section Plinths

Medi **Plinth**

### Four or five section rehabilitation plinths

Medi-Plinth's professional range of highly stable and durable rehabilitation plinths. Utilising the highest quality materials and innovative design to give the clinician a robust platform to work.

The Physio+ range offers great clinician access and patient positioning, whilst providing unrivalled reliability.

- 260kg safe working load for electric versions
- 225kg safe working load for hydraulic versions
- Paper roll holder fitted as standard
- Anti-entrapment 'Suspa' gas strut operated back/footrests
- Stitched key hole shaped ergonomic breathing hole and bung
- Single Foot switch fitted on electric versions
- Adjustable foot for stability on uneven floors
- Upholstery gusset linking all sections and covering hinge points
- Retractable, easy clean 'Tente' castors
- Precision self-lubricating bearings on all pivot points
- Low entry height: Ideal for wheelchair transfers
- Mobile Hoist clearance beneath base frame
- Industry leading Linak 'High Reliability' actuators
- Manufactured in the UK and CE Marked

### Specification:

- Length: 186cm
- Width: 63cm
- Head/Foot Adjustment: -20° to +80°
- Height Max: 91cm
- Height Min: 46cm



### Warranty:

These robustly constructed products will operate for many years with little attention, an annual service is advised.

We offer a comprehensive parts and labour warranty to cover manufacturing or material defects of **seven years for the frame and three years for moving parts.**

**PHYS+04H** Physio+ Four Section Plinth - Hydraulic

**PHYS+04E** Physio+ Four Section Plinth - Electric

**PHYS+05H** Physio+ Five Section Plinth - Hydraulic

**PHYS+05E** Physio+ Five Section Plinth - Electric

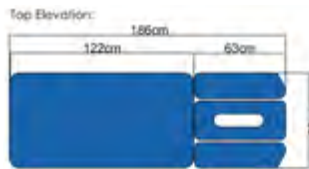

Operational Parameters:

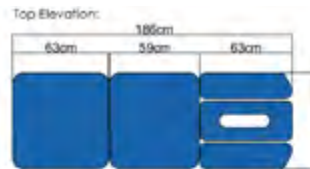
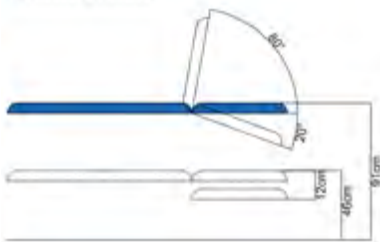

Operational Parameters:

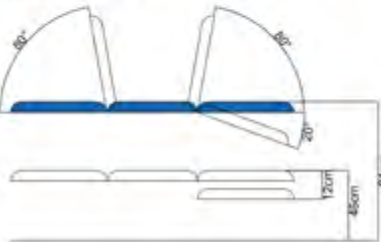

### MRSA resistant anti bacterial & fire retardant vinyl colours:

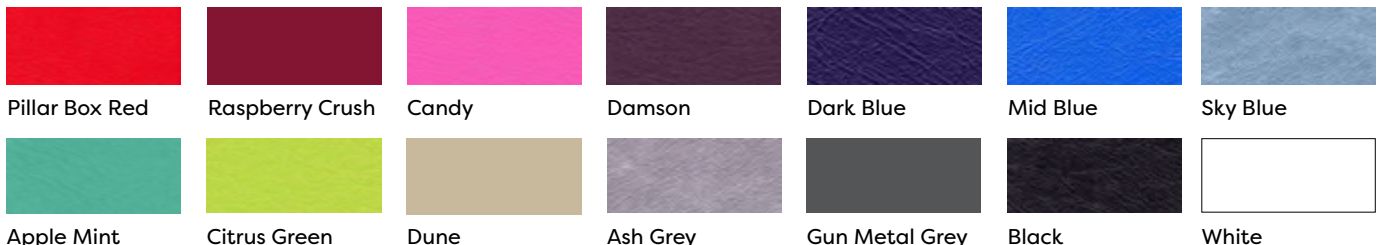

## Physio+ Bo Plinths

Introducing the new, improved range of highly stable and durable Bobath rehabilitation plinths. Utilising the highest quality materials and innovative design, giving clinicians a robust platform from which to work.

- 320kg safe working load
- Electrically operated back section on two section variant
- Paper roll holder fitted as standard
- Anti-entrapment 'Suspa' gas strut operated back/footrests
- Stitched key hole shaped ergonomic breathing hole and bung
- Single foot switch fitted as standard
- Adjustable foot for stability on uneven floors
- Upholstery gusset linking all sections and covering hinge points
- Retractable, easy clean 'Tente' castors
- Precision self-lubricating bearings on all pivot points
- Low entry height: Ideal for wheelchair transfers
- Mobile Hoist clearance beneath base frame
- Industry leading Linak 'High Reliability' actuators
- Manufactured in the UK and CE Marked

### Specification:

- Length: 186cm
- Width: 102cm
- Head/Foot Adjustment: -20° to +80°
- Height Max: 91cm
- Height Min: 46cm

### Warranty:

These robustly constructed products will operate for many years with little attention, an annual service is advised.

We offer a comprehensive parts and labour warranty to cover manufacturing or material defects of **seven years for the frame and three years for moving parts.**

# Medi Plinth



B

Furniture

**PHYS+MTE** Physio+ Bo Plinth Mat Table - Electric

**PHYS+BOE** Physio+ Two Section Bo Plinth - Electric

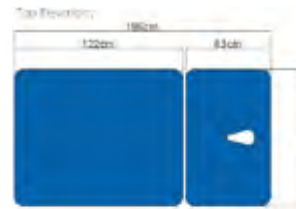

Operational Parameters:



### MRSA resistant anti bacterial & fire retardant vinyl colours:

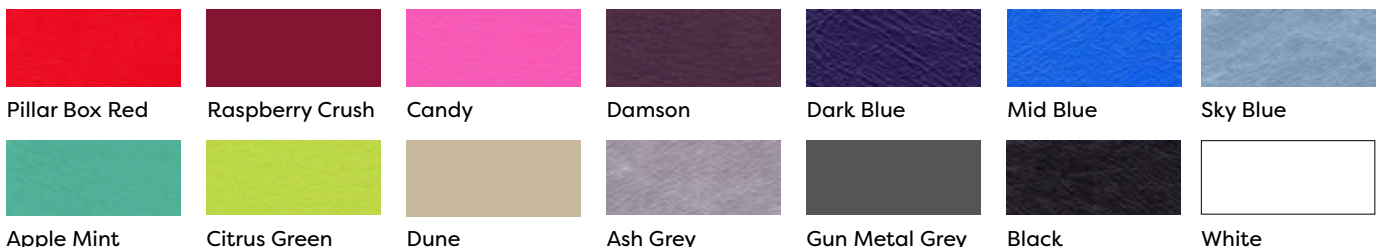

## Medi-Plinth Accessories

Medi-Plinth offer a vast range of additional accessories to compliment their couches.

These plinth accessories may be purchased separately from Medi-Plinth couches.

**Medi Plinth**

Fold Down Arm Loops



AL01

Phlebotomy Arms



PHL1

Cot Sides Chromed



CO01C-P Pair

Cot Sides Chromed Padded



CP01C-P Pair

Cot Sides Painted



CO01-P Pair

Cot Sides Chromed Padded



CP01-P Pair

Detachable Headrest



DHR01

Divided Legs



DI01

Treatment/ Plaster Table



DPT1

Foot Switch



FO01 Single

Gynae Stirrups



GY01

Gynae Knee Troughs



GY03

Gynae Foot Pads



GY05

Oxygen Bottle Holder



OBH

Paper Roll Holder



PR01

Super Soft Upholstery



SSUPH

Velcro Harness 3pk



VE03

Foot Section Wall Bracket



WSB01

Foot Protection Cover



FP01

Swing Down Arm Rests



SDA01

Trapezium Positioning Aid



WEDGE001

Semi-Circular Positioning Aid



WEDGE002

Triangular Positioning Aid



WEDGE003

Rectangular Positioning Aid



WEDGE004

## Medi-Plinth Options

Medi-Plinth offer a vast range of options to be added to plinths in order to meets your needs.

These plinth options must be purchased at the time of ordering a plinth.

Visco Memory Foam Mattress



VS01

Clean Edge Base Cover



CL2

Linked Castor Base System



LCB01

Battery Operating System



BOS

Battery Back Up



BBU

Electric Tilting Seat



EB02

Breathing Hole & Bung



BR01

Stitched Breathing Hole & Bung



BR02

Long Breathing Hole & Bung



BR03

Electric Back Rest

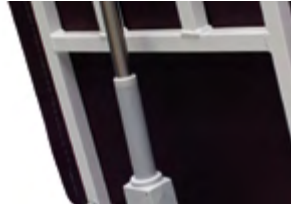

EB01

Extra Wide Upholstery

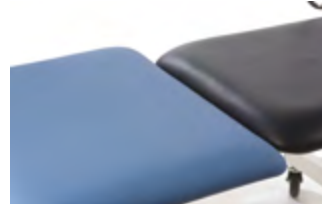

EW1

Transportation Castors



CA01

Adjustable Arm Rests



DE01

Bariatric Arm Rests



BE01

Tilting Patient Table



PT02

Tilting Foot Board



TF01

Padded Arm Table Extensions



AR01

IV Drip Pole and Bracket



DP01

Peripheral Foot Bar



PFB02

Fold Down Padded Arm Rests



FDPA01

## Care Sure Hospital Ward Bed

Our versatile Care Sure hospital ward bed is designed to meet the needs of any modern hospital environment.

The bed is fully adjustable with intuitive controls and reliable features for optimum patient comfort and care.

### Structure

- Epoxy coated steel tube frame
- Removable head and foot boards
- Easily removable patient platform sections
- Supports weights of up to 250 kg

### Comfort

- Four independent folding side rails
- Single-hand side rail operation
- 'Help to stand' button
- Automatic positioning system for protection against bedsores
- Integrated pull-out linen shelf
- Bed alarm automatically sounds when backrest is positioned at 30°

### Ease Of Handling

- In-built software to smoothed and synchronized movements and positioning
- Easy to understand symbols on handset
- Foot pedal controls height adjustment and can be accessed from either side of bed
- Centralised braking system and steering facility
- Large medical grade anti-static castors

### Positioning

- Foot section includes electrically controlled kneebreak allowing for five positions
- 5 preprogrammed functions, which includes cardiac chair & CPR
- Exit position button, allows for easy transfer

### Safety

- Emergency release of backrest for quick lowering in an emergency
- Double LED safety positioning light
- Anti-trapping sensor with automatic engine stop
- Medical grade electric motors with integrated anti-collapse safety measures
- IPX6 protection against water and dust ingress
- Conforms to Regulation (EU) 2017/745

**HCF207** Medi-Plinth Care Sure Hospital Bed

**HCF207.1** Care Sure 5th wheel

**HCF207.2** Care Sure Backrest Guides (for RX cassette)

**HCF207.3** Care Sure Foot pedal controls (Height)

**HCF207.4** Care Sure Foot pedal controls (exam. & exit position)

**HCF207.5** Care Sure Unbraked wheel alarm

**HCF207.6** Care Sure Adjustable IV pole

**HCF207.7** Care Sure Lifting pole

**HCF207.8** Care Sure Oxygen bottle holder

**HCF207.9** Care Sure Table for footboard

### Controls

- Clinician handset (outside of rail)
- Patient handset (inside of rail)
- Nurse handset (external)

### Specifications

- External dimensions: 223 x 98 cm
- Patient Surface: 200 x 85 cm
- Height adjustment: 39-77 cm
- Back / Leg / Foot tilting: 67° / 28° / 19°
- Trendelenburg / Reverse: ±16°
- Backrest autoregression: 15 cm
- Footrest autoregression: 7 cm
- Safe working load: 250kg
- Weight w/o accessories: 150kg

Medi **Plinth**





## Birth Sure Delivery Bed

Designed to meet both modern gynaecology & maternity requirements in hospital environments, as well as provide post-partum support. This birthing bed includes features to aid comfort and provide support during and following childbirth.

### Structure

- Epoxy-coated steel tube frame
- Headboard and footboard easy to assemble without tools.
- Retractable floor support
- Scissor-lift system provides optimum stability and supports weights of up to 250 kg

### Comfort

- Independent and removable ABS sections.
- Bed fully adjustable with medical grade electric motors compliant with EN 60601-1
- Ergonomic foot section extends bed by up to 20cm and slides under the bed when not in use
- Electric height adjustment, 64-100cm

### Ease Of Handling

- Handset designed to allow easy and quick positioning of the bed sections
- Electric Trendelenburg / Reverse Trendelenburg positioning
- Electric seat section tilts pelvis up to 30°
- Optional integrated controls in side rail

### Positioning

- 4 preprogrammed functions, including CPR & Shock Position
- The bed is suitable for gynaecological and maternity patients at any stage of pregnancy or childbirth, as well as post-partum

### Safety

- Ø 150mm diameter castors with central braking and steering facility operated from head-end for portering
- Thermoplastic main frame protects the bed mechanism and facilitates easy cleaning
- Height adjustment system prevents collapse in case of failure
- Anti-trapping system that automatically stops the motor on detection of an obstacle
- Emergency release provides quick lowering of the bed backrest in an emergency
- Conforms to Regulation (EU) 2017/745

### Easy Cleaning

- Manufactured from high quality materials, guaranteeing their long life and durability
- Smooth surfaces and removable panels allow easy, fast cleaning and disinfection
- Designed to improve cleaning time by up to 30%, allowing staff more time with the patient as opposed to cleaning

### Specifications

- Total Length: 212 cm
- Length (Chair position): 164.5 cm
- Width (with rails): 103 cm
- Patient surface width: 89 cm
- Height (floor to frame): 64-100 cm
- Backrest tilting: 70°
- Seat section tilting: 17°
- Trendelenburg / Reverse: 16° / 5°
- Safe working load: 250kg

Medi Plinth



**HCF208** Medi-Plinth Birth Sure Delivery Bed

**HCF208.1** Birth Sure Nurse handset panel

**HCF208.2** Birth Sure Accessories Trolley

**HCF208.3** Birth Sure IV Pole

**HCF208.4** Birth Sure Foot switch controls

## Motion Transport Stretchers

Advanced specification transport stretchers for efficient patient transport and transfer as required. Integrated siderails for security and thick mattress provides comfort.

### Structure

- Epoxy coated steel tube frame
- Two/Four section platform made of damp-proof, impact resistant HPL material
- Completely X-ray translucent patient platform
- Smooth surfaces and removable panels allow easy, fast cleaning and disinfection
- Integrated Height adjustable and foldable IV pole

### Comfort

- High-density polyurethane construction mattress for optimum comfort
- Hydraulic Trendelenburg/reverse Trendelenburg positions
- Foot pedals at either side of the stretcher control height, Trendelenburg and reverse Trendelenburg adjustment

### Ease Of Handling

- Collapsible and integrated push handles
- Central braking system
- 5th castor for improved bed manoeuvrability and control
- Integrated oxygen bottle holder

### Positioning

- Hydraulically operated backrest and height adjustment from 66–97.5 cm
- IV pole sockets on each corner
- Bilateral lever for leg section adjustment (4 sect.)

### Safety

- 10cm fire-resistance mattress (BS 7176 - Medium Hazard)
- Mattress upholstered with antimicrobial, anti-static covering.
- Integrated siderails fold down below height of mattress for simpler and safer patient transfers
- Buffers located on each corner of the stretcher
- ABS base cover protects the stretcher mechanism and facilitates easy cleaning
- Conforms to Regulation (EU) 2017/745



**HCF202** Two Section – Medi-Plinth Motion Stretcher Trolley

**HCF202.1** Four Section – Medi-Plinth Motion Stretcher Trolley

**HCF202.2** Motion Stretcher Patient transfer table

**HCF202.3** Motion Stretcher Arm supports

**HCF202.4** Motion Stretcher Paper roll holder

**HCF202.5** Motion Stretcher RX cassette holder

**HCF202.6** Motion Stretcher Footboard with monitor table

**HCF202.7** Motion Stretcher Visco elastic mattress with cover

**HCF202.8** Motion Stretcher Oxygen bottle holder

**Medi Plinth**



### Specifications

- Backrest tilting: 90°
- Legrest tilting (4 sect.): 35°
- Trendelenburg / Reverse: ±18°
- Weight w/o accessories: 100/110kg
- Safe working load: 317kg
- Overall dimensions (2 sect.): 218 x 82cm
- Back section dimensions (2 sect.): 62 x 71cm (2 sect.)
- Leg section dimensions (2 sect.): 66 x 116cm
- Overall dimensions (4 sect.): 210 x 82cm
- Back section dimensions (4 sect.): 62 x 71cm (4 sect.)
- Leg section dimensions (4 sect.): 62 x 34cm
- Foot section dimensions (4 sect.): 62 x 47cm



## Solace Dialysis Chair

Offering a versatile, adjustable, comfortable platform for patients undertaking dialysis procedures. Electric height adjustment and upholstered, contoured seat sections.

### Structure

- Epoxy-coated steel tube frame.
- Scissor-lift system provides optimum stability.
- Supports weights of up to 230 kg.

### Comfort

- 100% usable patient surface.
- High-density polyurethane foam backrest and seat.
- Fully adjustable contoured polyurethane armrests.
- Integrated height-adjustable headrest.

### Ease Of Handling

- Handset controls independent electric adjustment of height, backrest, legs and Trendelenburg position.
- Central braking system.
- Electric adjustment of footrest.
- Integrated portering handle for ease of transport

### Positioning

- Foot section includes electrically controlled kneebreak.
- Includes two pre-programmed functions:
  - Emergency Trendelenburg (shock position)
  - Patient exit position (height descends to minimum, backrest and legrest move to chair position)

### Safety

- Emergency release for quick lowering of backrest
- Anti-trapping system that automatically stops the motor on detecting an obstacle
- Low-voltage electric motors compliant with EN 60601-1
- Conforms to Regulation (EU) 2017/745

### Upholstery

- Manufactured from high quality materials, guaranteeing their long life and endurance.
- Upholstered in self-extinguishing vinyl fabric (according to M2 standard. EN1021.1-2) antibacterial and resistant to absorption and stains, easy cleaning and maintenance.



**HCF201** Medi-Plinth Solace Dialysis Chair

**HCF201.1** Solace IV Pole

**HCF201.2** Solace Foot Tray

**HCF201.3** Solace paper roll holder

### Specifications

- Patient surface: 214 x 57 cm
- External dimension: 220 x 87.5 cm
- Backrest dimensions: 88 x 57 cm
- Seat dimensions: 54 x 57 cm
- Legrest dimensions: 72 x 57 cm
- Height adjustment: 51-76 cm
- Backrest tilting: 72°
- Footrest dimensions: 25 x 58 cm
- Trendelenburg: 25°
- Safe working load: 230 kg
- Weight w/o accessories: 98 kg

**Medi Plinth**



Made in the UK



Free Delivery



## Breeze Elevate Patient Chair

Our premium model Hi-Low electric adjustable-height patient chair offers versatility combined with complete patient comfort.

Easy to control and safe to use, this hydraulic lift model allows patients to be raised in the seat allowing ease of access for care-giver.

### Structure

- Epoxy-coated steel tube frame.
- IV pole socket and hooks for urine bags.
- Footrest attached under-seat.
- Supports weights of up to 180kg.

### Comfort

- High backrest, padded in high-density PU foam
- Removable, height-adjustable padded headrest
- Contoured front to the backrest stimulates blood circulation.
- Five setting high adjustable polyurethane armrests
- "Zero gravity" backrest and seat tilting system

### Ease Of Handling

- Hydraulic height adjustment by bilateral foot pedals
- Independent adjustment of backrest and legrest
- Ergonomic handle for easy transport.
- Central braking system
- Accessible for lifts/hoists from front section
- Suitable for overbed tables.

### Easy Cleaning

- Manufactured from high quality materials, guaranteeing their long life and endurance.
- Upholstered in self-extinguishing vinyl fabric (according to M2 standard. EN1021.1-2) antibacterial and resistant to absorption and stains, easy cleaning and maintenance.

### Upholstery

Upholstered in self-extinguishing vinyl fabric (according to M2 standard. EN1021.1-2) antibacterial and resistant to absorption and stains, easy cleaning and maintenance.

### Specifications

- Overall dimensions: 122.5 x 72 x 88cm
- Extended length: 163cm
- Back section dimensions: 84 x 51cm
- Seat dimensions: 51 x 54 x 54-80cm
- Leg section dimensions: 51 x 34cm
- Footrest dimensions: 29-35 x 22cm
- Backrest tilting: 85-168°
- Weight w/o accessories: 45kg
- Safe working load: 180kg



**HCF200** Breeze Elevate Patient Chair

**HCF197.2** Breeze Chair IV Pole

**HCF197.3** Breeze Chair Patient Tray

**HCF197.4** Breeze Chair Paper roll holder

Medi Plinth



## Breeze Patient Chairs

Our latest models of ergonomic, easily-portable patient chairs with reclining seat and adjustable armrests.

Available in two or four wheel options with choice of foot support, also offered as the breeze plus model with integrated central locking system.

Available in two or four wheel options. Breeze plus model includes integrated central locking system.

### Structure

- Epoxy-coated steel tube frame.
- IV pole socket and hooks for urine bags.
- Footrest attached under-seat.
- Supports weights of up to 180kg.

### Comfort

- High backrest, padded in high-density PU foam.
- Removable, height-adjustable padded headrest.
- Five setting high adjustable polyurethane armrests.
- “Zero gravity” backrest and seat tilting system.

### Ease Of Handling

- Independent adjustment of backrest and legrest
- Kick brakes on castors (central braking system on Plus model)
- Handle included for easy transport (excludes 2-Wheel chair)
- Four Ø100 mm braked castors or improved manoeuvrability

### Easy Cleaning

- Manufactured from high quality materials, guaranteeing their long life and endurance.
- Upholstered in self-extinguishing vinyl fabric (according to M2 standard. EN1021.1-2) antibacterial and resistant to absorption and stains, easy cleaning and maintenance.

### Upholstery

Upholstered in self-extinguishing vinyl fabric (according to M2 standard. EN1021.1-2) antibacterial and resistant to absorption and stains, easy cleaning and maintenance.

### Specifications

- Overall dimensions: 122.5 x 72 x 86cm
- Extended length: 165cm
- Back section dimensions 84 x 51cm
- Seat dimensions: 52 x 52 x 46cm
- Leg section dimensions: 51 x 34cm
- Footrest dimensions: 29-35 x 22cm
- Backrest tilting: 85-168°
- Weight w/o accessories: 45kg
- Safe working load: 180kg



### Chair Accessories

**HCF197.2** Breeze Chair IV Pole

**HCF197.3** Breeze Chair Patient Tray

**HCF197.4** Breeze Chair Paper roll holder

Medi Plinth

 Made in the UK

 Free Delivery



**HCF198** Breeze 2-Wheel Patient Chair



**HCF197** Breeze 4-Wheel Patient Chair - With foot support

**HCF197.1** Breeze 4-Wheel Patient Chair - Without foot support



**HCF199** Breeze 4-Wheel Patient Chair - Central Brake & foot support

## Paediatric Child Assure Cot

A secure, comfortable fixed-height cot offering a quality support platform for children in care. With features to enhance care, including 360° visibility siderails and nappy storage.

### Structure

- Epoxy coated steel tube frame
- Two section platform made of epoxy coated enamelled steel.
- Four independent sockets for accessories (IV pole, mosquito net, etc.)
- Fixed height of 740mm.

### Comfort

- Two independent sections made of damp-proof and impact-resistant HPL material, resistant to humidity and shock.
- 100% usable patient surface.
- Adjustment backrest (semi-fowler position).

### Ease Of Handling

- Hydraulic Trendelenburg / reverse Trendelenburg  $\pm 13^\circ$ .
- Central braking system.
- Seven position sliding siderails for easy access.
- Nappy/storage tray located to the base of the cot.

### Safety

- Peripheral vision of 360° with transparent side rails
- Single point sliding side rails, with soften lowering system and safety plunger to avoid accidental opening.
- Anti-entrapment system at section joints.
- Four bumpers (one on each corner of the bed) integrated into structure, avoiding damage and reducing the required space
- Conforms to Directive 2007/47/CEE.

### Specifications

- Height to mattress: 75cm
- Overall dimensions: 86 x 54 x 136.5cm
- Trendelenburg / Reverse:  $\pm 13^\circ$
- Safe working load: 85kg
- Weight w/o accessories: 57kg

Medi Plinth



**HCF203** Medi-Plinth Paediatric Child Assure Cot

**HCF205.1** Child Assure IV Pole

**HCF205.2** Child Assure PU Mattress with cover (Assure)

## Paediatric Child Assure Care Cot

Our electric height adjustable care cot offering a versatile support platform for children in higher care. With further features to ensure safe, comfortable care.

### Structure

- Epoxy-coated steel tube frame
- Four sockets for accessories (IV pole, mosquito net, etc.)
- Four bumpers (one on each corner of the bed) integrated into structure, avoiding damage and reducing the required space

### Comfort

- Two independent sections made of damp-proof and impact-resistant HPL material, resistant to humidity and shock.
- 100% usable patient surface

### Ease Of Handling

- Electric height adjustment ranging from 58 cm to 90 cm by electric actuators.
- $\varnothing$  100 mm castors with central braking system and steer.
- Quick emergency release backrest system for emergency events or electrical failure.
- Electric Trendelenburg / reverse Trendelenburg positioning.
- Clinician handset for ease of use.

### Safety

- Peripheral vision of 360° with transparent end rails
- Single point sliding side rails, with soften lowering system and safety plunger to avoid accidental opening.
- Anti-entrapment system at section joints
- Quick emergency release backrest system
- Conforms to Regulation (EU) 2017/745

### Specifications

- Surface dimensions: 140 x 72cm
- Overall dimensions: 157.5 x 89 x 155cm
- Backrest angle: 75cm
- Trendelenburg / Reverse:  $\pm 16^\circ$
- Safe working load: 85kg

Medi Plinth



**HCF204** Medi-Plinth Paediatric Child Assure Care Cot

**HCF205.1** Child Assure IV Pole

**HCF205.3** Child Assure PU Mattress with cover (Assure Care/Intensive)

## Paediatric Child Assure Intensive Cot

Our advanced paediatric cot offering a high-quality support platform and a comprehensive range of features to combine patient comfort & security.

### Structure

- Epoxy-coated steel tube frame
- Four independent sockets for accessories (IV pole, mosquito net, etc.)
- Four bumpers (one on each corner of the bed) integrated into structure, avoiding damage and reducing the required space
- ABS covered base that protects the mechanisms and allows easy cleaning with area for oxygen bottle holder.
- Fixed height of 740mm.

### Comfort

- Four independent sections made of damp-proof and impact-resistant HPL material, resistant to humidity and shock.
- 100% usable patient surface

### Ease Of Handling

- Hydraulic Trendelenburg / reverse Trendelenburg  $\pm 13\text{deg}$
- Central braking system
- Seven position sliding siderails for easy access
- Nappy/storage tray located to the base of the cot.

### Safety

- Single point sliding side rails, with soften lowering system and safety plunger to avoid accidental opening.
- Peripheral vision of  $360^\circ$  due to its side rails made of transparent material, with compliant safety distances at sections joints to prevent entrapments.
- Compliant safety distances at all sections and joints to prevent any entrapments.
- Conforms to Regulation (EU) 2017/745

### Specifications

- Height to mattress: 75cm
- Overall dimensions: 86 x 54 x 136.5cm
- Trendelenburg / Reverse:  $\pm 7^\circ/18^\circ$
- Safe working load: 85kg
- Weight w/o accessories: 90kg

**Medi Plinth**



**HCF205** Medi-Plinth Paediatric Child Assure Intensive Cot

**HCF205.1** Child Assure IV Pole

**HCF205.3** Child Assure PU Mattress with cover (Assure Care/Intensive)

## C-Arm Imaging Table

### Designed for a wide range of applications including:

Day Surgery, Vascular Studies and Pain Management Procedures.

Combining 150cm of artefact free imaging platform with innovative column lift technology. Low entry height, providing superb access for most challenged patients and the accessory range provides positioning solutions for most procedures.

- 150cm Unobstructed artefact free imaging area
- Carbon Fibre Top dimensions: 208cm x 61cm (Length x Width)
- Lowered Height: 58cm (excluding mattress)
- Highest Height: 98cm (excluding mattress)
- Safe Working Load: 200kg (evenly distributed)
- Narrow base frame for ease of patient transfer
- Fully-locking medical grade anti-static castors
- Easy access emergency stop button for patient safety
- Full range of accessories offer solutions for most procedures
- Manufactured in the UK and CE Marked

**CTABLE001** C-Arm Imaging Table

**CTABLEAC01** Full Length Accessory Rails (Pair)

**CTABLEAC02** Lithium Battery Operating System

**CTABLEAC03** Handle Bar (Stainless Steel)

**CTABLEAC04** Mattress with Facehole (Anti-static/Visco Foam)

**CTABLEAC05** Foot Switch Controls

**Medi Plinth**



## Hillrom 900 Bed

Offers maximum functionality with minimal complexity, so you spend less time operating the bed and more time focusing on essential tasks such as mobilising your patients.

With the help of carefully designed functions such as the Intelligent Auto Contour™, the EasyChair™ and Flat positions, the Care grip and the one-button egress position, you can effectively progress your patient through the steps of mobility.

- The lowering of the split siderails can be activated using one hand and feature a smooth, rapid selflowering mechanism allowing for quick access to patients
- Stable support is provided during bed exit via an ergonomically-placed side egress grip handle
- Intuitive bed controls require minimal in-service staff training and help minimise the risk of user's error
- One-Touch Side Egress positions the bed for safer and easier bed exit
- AutoContour™ and SlideGuard™ minimise patient migration in bed, reducing abdominal compression during bed articulation
- EasyChair™ and flat position function offers patients the ability to quickly reach a comfortable seated position
- Low height indicator warns the caregiver if the bed is not in the lowest position, contributing to a safer patient environment
- 5th castor facilitates easier bed transport in any direction
- One-Touch Shock positioning flattens the upper deck and places the bed into a Trendelenburg position, should patient complications occur
- Intelligent night light enhances operational safety for both patients and caregivers
- Alerts caregivers of potential bed exit via the 3-Mode Bed Exit Alarm, available with remote monitoring capabilities

- **Safe Working Load:** 250 kg
- **Bed Weight:** 144 kg
- **Height Adjustment:** 38.9 – 76.8 cm
- **Protection Class:** IPX4
- **Sleep Deck (W x L):** 90 x 200 cm
- **Head Section Angles:** 0 to 65°
- **Thigh Section Angles:** 0 to 28°
- **Foot Section Angles:** -22 to -3°
- **Trendelenburg/Reverse:** -17 to +17°



**HCF001** Hillrom 900 Bed (Mattress not included)

## Hillrom Centuris Pro Bed

### An affordable option for quality care

The Centuris™ bed's numerous features and ergonomic design help provide safer patient mobility and caregiver ease-of-use.

It meets the most recent international regulatory requirement IEC/EN 60601-2-52 concerning the basic safety and essential performance of hospital beds for adults.

- AutoContour™ and SlideGuard™ minimise patient migration in bed, reducing abdominal compression during bed articulation
- Easy-to-read Line-Of-Site™ backrest indicator assists in implementing caregiver protocols
- The lowering of the split siderails can be activated using one hand and feature a smooth, rapid self-lowering mechanism allowing for quick access to patients
- Stable support is provided during bed exit via an ergonomically-placed side egress grip handle
- Functional lock-out on controls offers enhanced operational safety
- A 220 kg safe Working Load accommodates a greater range of patients
- 150 mm single band castors including steering castor allow for ease of manoeuvrability
- Centralised braking enhances patient safety
- The Trendelenburg/Reverse Trendelenburg function facilitates
- easier patient repositioning
- Choose from either a hand-held pendant control or integrated controls, both of which simplify operational functioning of the bed for caregivers

- **Safe Working Load:** 220 kg
- **Bed weight:** 133 kg
- **Height adjustment:** 39 to 77 cm
- **Protection class:** IPX4
- **Sleep Deck (W x L):** 90 x 200 cm
- **Head Section Angles:** 0 to 65°
- **Thigh Section Angles:** 0 to 28°
- **Foot Section Angles:** -22 to -3°
- **Trendelenburg/Reverse:** -17 to +17°



**HCF002** Centuris Pro bed with split siderails (Mattress not included)



## Hillrom P290 Surface

The P290 surface is designed to help prevent and treat pressure ulcers in low to high-risk adult patients. The surface provides an adjustable level of immersion and envelopment in both Alternating and Continuous Low Pressure therapy modes to suit your patient's needs and your clinical preference.

- Three pressure-redistributing zones provide additional protection for vulnerable body areas, including a 5° sloped alternating heel zone.
- Adjustable cycle times and firmness setting for greater control over patient therapy and comfort
- Patient and caregiver safety features, including automatic control panel lock-out, fault indicators and two-hour transport mode
- P-MAX and PLUS inflation for additional support and safety during patient positioning and transfer activities



 Hillrom..

HCF014 Hillrom P290 Surface

## Hillrom NP50 Prevention Surface

The Hillrom® NP50 foam surface is an affordable and comfortable solution for your patients and is available for acute care, extended care and home care environments.

This non-powered surface is lightweight, easy to clean, and is designed to conform with bed frame articulations. This economical solution is also available in larger sizes and can be purchased with optional bolsters/raised perimeter.

- Polyurethane coated nylon ticking protects the mattress from any fluid penetration
- Anti-skid bottom prevents movement to help keep the mattress in place on the sleep deck
- Optional bolsters/side perimeter keep patients centred and oriented are available



 Hillrom..

HCF015 Hillrom NP50 Prevention Surface

## Hillrom NP150 Viscoelastic mattress

Specially developed to help prevent pressure ulcers. The temperature sensitive, viscoelastic foam moulds to the patient's shape, evenly distributes the weight and contours to the body in any position, increasing patient comfort and pressure redistribution. It is adaptable to most bed frames and conforms to all bed positions.

- Conforms to body shape and reduces interface pressure
- Welded cover with built-in carry handles
- Easy to clean and hygienic
- High density side sections designed for patient safety and improved egress
- Adapts to most bed frames and conforms to all bed positions
- X-ray translucent\* and latex-free
- Safe working load: 250kg



 Hillrom..

HCF016 Hillrom NP150 Viscoelastic mattress

## Hillrom Accella Therapy Mattresses

Reduce patient discomfort with SlideGuard™, especially designed to minimise the need for patient repositioning

- Improves workflow efficiency with an integrated scale and BMI calculation, excluding the weight of accessories and IV poles, therefore reducing steps to obtain patient weight
- Available on the right or left side of the bed, the bright and easy-to-use Graphical Caregiver Interface (GCI) offers straightforward visuals of patient information
- One-Touch Side Egress positions bed for safer and easier exit
- Stable support is provided during bed exit via an ergonomically-placed side egress grip handle
- Optimise patient care with Head-of-Bed Angle Alarm, alerting caregivers of any safety concerns
- Safe working load: 250kg



 Hillrom..

HCF017 Hillrom Accella Therapy Mattresses

## INNOV8 iQ Hospital Bed

This innovative ward bed achieves the optimum combination of safety, performance, functionality and cost efficiency.

- Low height reduces risks associated with patient falls and increases patient independence
- The simultaneous operation of the cardiac chair and tilt functions combined with auto regression improves patient positioning, mobilisation and rehabilitation
- Backrest and mattress angle indicators
- Low height foot end to improve the visibility for the patient
- Removable head and foot ends are also available in a number of colour options for ward management
- Movable catheter hooks can be placed in different locations around the bed for convenience and ease of use
- Easy access manual CPR handle with CPR mechanism
- Electric CPR is located on the nurse handset
- Integral bed extension combines ease of use and functionality
- The patient handset clip fits neatly around the side rail to reduce movement and ensure accessibility where required
- Blow moulded panels incorporate a series of perforations to accommodate a wide variety of dynamic mattresses
- Newly designed linen shelf is easier and smoother in operation, can be operated with one hand
- Open and accessible areas with smooth surfaces facilitate ease of cleaning & decontamination, allowing steam cleaning
- Extremely lightweight bed ensures ease of manoeuvrability with minimal effort
- The built in diagnostics port allows for swift and easy maintenance procedures
- Brake bar/pedal ensures easy access from head or side
- Triple function castors enable brake, free and track Mattress

**Platform Length:** 200cm

**Width:** 88cm

**Outside Bed Length Standard:** 226cm / **Extended:** 246cm

**Outside Bed Width:** 103cm

**Height Mattress Platform Max:** 74cm / **Min:** 34cm

**Min Height Panel Base:** 293cm

**Overall Bed Weight:** 115kg

**Safe Working Load:** 254kg

**Maximum User Weight:** 190kg



**HCF899.1** INNOV8 iQ Hospital Bed with Standard Side Rails

**HCF899.2** INNOV8 iQ Hospital Bed with High Side Rails

## INNOV8 Low Bed

The Innov8 Low height bed has an exceptional low height and with its key features, can be utilised as an everyday acute ward bed without compromising on patient outcomes.

Falls prevention is a major risk management consideration in hospitals today. Sidhil's Innov8 Low acute hospital ward bed provides a fully functional solution, with the added benefit of an extremely low platform height at just 22cm.

- The Innov8 Night Pack illuminates the underside of the bed improving patient safety and security
- Easy to clean and decontaminate, as the bed incorporates BioCote
- Electrically operated backrest, height & knee break with battery backup
- When lowering the bed from maximum height the bed will travel at full speed until it reaches 42cm, at which point it will slow and a short warning alarm will sound to alert the carer that the bed is now travelling lower than a standard bed
- Exceptionally low platform height of 22cm with features that enable it to be utilised as an everyday acute ward bed
- 12cm under bed clearance for hoist (minimum mattress platform height 40cm)
- Auto-cardiac chair position (as per standard Innov8)
- Central locking braking system - dual sided
- Extendable mattress platform length for taller patients
- Easy to manoeuvre, reducing back or handling problems
- Removable head/foot ends with colour coding options
- Maximum patient weight of up to 30 Stone (190kg)
- IP54 standard ingress protection
- UK manufacture and support

**Mattress Platform Height:** 22cm to 71cm

**Width:** 102cm

**Length:** 218cm (238cm when fully extended)

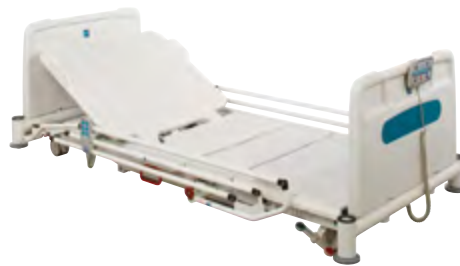

**HCF891** INNOV8 Low Bed with Standard Rails

## Bradshaw Junior Care Bed

Sidhil's brand new paediatric bed, the Bradshaw Junior has been specially designed to safely accommodate younger patients in a hospital, nursing or community environment

- Electrically operated fully profiling paediatric care bed smaller design to comfortably accommodate the younger patient
- Bright, colourful appearance with full length integral side rails
- Adjustable self locking side rails providing additional safety which can also be released at both head and foot ends
- Lockable handset
- Max User Weight: 178kg (28 stone)

### Standard Dimensions:

**Height:** 39–81cm  
**Width:** 93cm  
**Length:** 208cm

### Low Dimensions:

**Height:** 28–70cm  
**Width:** 93cm  
**Length:** 208cm



**HCF1290** Bradshaw Junior Care Bed (Standard)

**HCF1290.1** Bradshaw Junior Care Bed (Low)

**HCF1291** Sidhil Softrest Junior Mattress

## Sidhil Hybrid Power Mattress

Combines the pressure redistribution properties of high spec foam, with alternating pressure relief. Conforms to the shape of the body, while the alternating cells assist with the pressure relief. There is no need to move the patient to step them up to an alternating system or step them down to a static mattress.

- Cover can withstand a higher concentration of cleaning substances and offers greater resistance to abrasion
- High frequency welded seams protect against fluid ingress
- 360° zip to prolong longevity
- Automatic lock out feature and low pressure alarm indicator
- Non-slip base prevents mattress from sliding out of position
- White inner substrate makes fluid ingress becomes easily identifiable to aid infection control guidelines
- Increased size turning pillow provides additional comfort
- High specification foam combined with alternating cells
- Castellated side formers to prolong longevity
- Zonal mattress gives additional support to vulnerable areas



**HDA581** Sidhil Hybrid Power Mattress

## E-MED One Day Extended Stay Trolley

An electrically operated four section trolley suitable for a wide range of applications but developed specifically for extended stay use. This trolley has a minimum platform height of 40cm, the lowest of our range, and a maximum height of 83cm.

- Platform length extends a further 18cm to accommodate taller patients
- Flexible controls for the patients comfort and ease
- Mattress included is water resistant, antibacterial and multi-stretch. It also has a removable cover
- Central break from either side of the trolley
- 200mm antistatic castors as standard
- Full range of accessories available
- **Length:** 199 - 217cm
- **Width:** 89.5cm
- **Height (min):** 40cm
- **Height (max):** 83cm
- **Mattress Platform Length:** 184 - 202cm
- **Mattress Platform Width:** 71cm
- **Safe Working Load:** 260kg (40st)
- **Max User Weight:** 225kg (35st)



**HCF1599** E-MED One Day Extended Stay Trolley

## Sunflower Fusion Classic Plus+ 2 & 3 Section Fully Powered Electric Couches

The new Fusion Classic Plus+ extends our already popular Fusion range, providing enhanced user functionality and easier patient positioning through its fully powered height, head and foot sections. Fusion Classic Plus+ is simply, strong, stable, aesthetically pleasing and easy to clean.

- Fully powered height adjustment 45-96cm
- Fully powered multi-position head section +70° / -35°
- Fully powered multi-position foot section +70° / -35°
- Maximum user weight 225kg (35st.)
- Easy to use handset
- Retractable positioning castors
- Adjustable height levelling foot
- Fully upholstered head & foot sections
- Double layer density foam for support & comfort
- Luxury 65mm deep contoured upholstery
- Anti-bacterial/anti-microbial vinyl
- Anti-bacterial Vinyl - Fire (Flammability) Testing BS 7176 Medium Hazard BS 5852 : 2006 Clause 11
- Paper roll holder (supplied as standard)
- Easy clean design and materials
- **NEW** 5 year warranty, lifetime warranty on frame



<b>SUN-FVHC-3E</b>	3 Section Electric Couch with powered height, head & foot section
<b>SUN-FVHC-2E</b>	2 Section Electric Couch with powered height & head section
<b>SUN-FVHC-LEG1</b>	Leg Supports
<b>SUN-FVHC-PHB1</b>	Phlebotomy Arm (each)
<b>SUN-FVHC-FSW1*</b>	Foot Switch
<b>SUN-FVHC-FSW2*</b>	Foot Switch 2 Section
<b>SUN-FVHC-FSW3*</b>	Foot Switch 3 Section
<b>SUN-FVHC-SUP1</b>	Gynae Stirrups
<b>SUN-CHP1</b>	Head Pillow
<b>SUN-FVHC-CBH1*</b>	Breathing Hole
<b>SUN-FVHC-RAIL*</b>	Medi-Rail Attachment
<b>SUN-FVHC-BB*</b>	Battery Backup
<b>SUN-FVHC-CSR*</b>	Folding Side Rails (pair)
<b>SUN-FVHC-IV2*</b>	IV Pole Attachment

			
<b>SUN-FVHC-LEG1</b> Leg Supports	<b>SUN-FVHC-PHB1</b> Phlebotomy Arm (each)	<b>SUN-FVHC-FSW1*</b> Foot Switch	<b>SUN-FVHC-FSW2*</b> Foot Switch 2 Section
			
<b>SUN-FVHC-FSW3*</b> Foot Switch 3 Section	<b>SUN-FVHC-SUP1</b> Gynae Stirrups	<b>SUN-CHP1</b> Head Pillow	<b>SUN-FVHC-CBH1*</b> Breathing Hole
			
<b>SUN-FVHC-RAIL*</b> Medi-Rail Attachment	<b>SUN-FVHC-BB*</b> Battery Backup	<b>SUN-FVHC-CSR*</b> Folding Side Rails (pair)	<b>SUN-FVHC-IV2*</b> IV Pole Attachment

\* these accessories can only be fitted when ordered with couch

### anti-bacterial vinyl upholstery colours please specify when ordering



+ Where lifetime warranty on frame is stated, the cover period for the frame is extended to 15 years from the date of despatch.



**SUN-FVHC-3E**  
3 Section electric couch with powered height, head & foot section

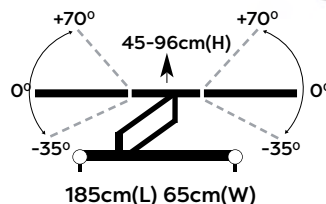

**SUN-FVHC-2E**  
2 Section electric couch with powered height & head section

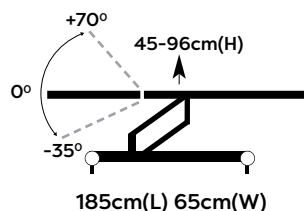

Normally delivered within 7-10 working days (\*UK Only)



Fully powered head and foot sections



Fully powered height adjustment

## Sunflower Fusion Gynae Couches

The new Gynae couch range features an ergonomic design providing comfort for the patient and ease of access and patient positioning for the clinician. Fusion Gynae is simply, strong, stable, aesthetically pleasing and easy to clean.

- Electric height adjustment 45 - 98cm (Hydraulic available)
- Maximum user weight 225kg (35st.)
- Gas assisted back  $-20^{\circ}$  /  $+80^{\circ}$  (SUN-FGYNE1)
- Electric powered tilting seat  $0^{\circ}$  /  $-15^{\circ}$  (SUN-FGYNE2 & SUN-FGYNE3)
- Fully powered head section (SUN-FGYNE3)
- Easy to use handset
- Rear retractable positioning castors
- 100mm Front braked castors
- Cut away lithotomy section for easier access
- 100mm Deep stainless steel operators tray
- Fully adjustable leg supports
- Fold down arms for patient comfort & security
- Double layer density foam for support & comfort
- Anti-bacterial/anti-microbial vinyl
- Anti-bacterial Vinyl - Fire (Flammability) Testing BS 7176 Medium Hazard BS 5852 : 2006 Clause 11
- Easy clean design and materials
- **NEW** 5 year warranty, lifetime warranty on frame



<b>SUN-FGYNE1</b>	Fusion Gynae 1-2 section couch - Electric powered height, gas assisted back, no seat tilt with arm supports & leg supports
<b>SUN-FGYNE2</b>	Fusion Gynae 2-2 section couch - Electric powered height, gas assisted back, powered tilting seat with arm supports & leg supports
<b>SUN-FGYNE3</b>	Fusion Gynae 3-2 section couch - Electric powered height, back and tilting seat with arm supports & leg supports
<b>SUN-FGYN-FSW1*</b>	Foot Switch
<b>SUN-FGYN-FSW2*</b>	Foot Switch (Gynae 2)
<b>SUN-FGYN-FSW3*</b>	Foot Switch (Gynae 3)
<b>SUN-FGYN-CHP1</b>	Head Pillow
<b>SUN-FGYN-CBH1*</b>	Breathing Hole
<b>SUN-FGYN-IV2*</b>	IV Pole Attachment
<b>SUN-FGYN-SUP1</b>	Stirrups (pair)
<b>SUN-FGYN-FS</b>	Detachable Foot Section Extension
<b>SUN-FGYN-WB</b>	Wall Bracket for Foot Section
<b>SUN-FGYN-BB*</b>	Battery Backup



**SUN-FGYN-FSW1\*** Foot Switch (Gynae 1)    **SUN-FGYN-FSW2\*** Foot Switch (Gynae 2)    **SUN-FVHC-FSW3\*** Foot Switch (Gynae 3)    **SUN-FGYN-CHP1** Head Pillow

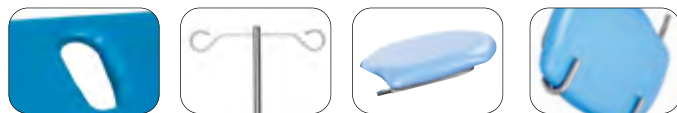

**SUN-FGYN-CBH1\*** Breathing Hole    **SUN-FGYN-IV2\*** IV Pole Attachment    **SUN-FGYN-FS** Detachable Foot Section Extension    **SUN-FGYN-WB** Wall Bracket for Foot Section



**SUN-FGYN-SUP1** Stirrups (pair)    **SUN-FGYN-BB\*** Battery Backup

### anti-bacterial vinyl upholstery colours please specify when ordering



+ Where lifetime warranty on frame is stated, the cover period for the frame is extended to 15 years from the date of despatch.



## FusionGynae



**SUN-FGYNE1**  
Fusion Gynae 1-2 section couch  
Electric powered height, gas assisted back,  
no seat tilt with arm supports & leg supports



**SUN-FGYNE2**  
Fusion Gynae 2-2 section couch - Electric  
powered height, gas assisted back, powered tilting  
seat with arm supports & leg supports



Normally delivered within  
7-10 working days (\*UK Only)

**SUN-FGYNE3**  
Fusion Gynae 3-2 section couch - Electric  
powered height, back and tilting seat with  
arm supports & leg supports

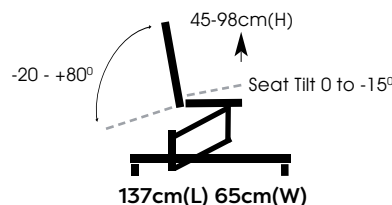

Detachable Foot  
Section Extension

50cm(L) 65cm(W)

## Sunflower Fusion ECO 2 Section Couches

The new Fusion Eco couch range provides most of the functionality you would expect for our standard Fusion range at a more affordable price to suit individual budgets. Fusion Eco is simply, strong, stable, aesthetically pleasing and easy to clean.

- Electric or hydraulic height adjustment 45 - 98cm
- Maximum user weight 250kg (40st.)
- Gas strut assisted multi-position head section
- Back rest adjustment +70° / -35°
- Easy to use handset (electric models only)
- Retractable positioning castors
- Adjustable height levelling foot
- Double layer density foam for support & comfort
- Luxury 65mm deep contoured upholstery
- Anti-bacterial/anti-microbial vinyl
- Anti-bacterial Vinyl - Fire (Flammability) Testing BS 7176 Medium Hazard BS 5852 : 2006 Clause 11
- Paper roll holder (supplied as standard)
- Easy clean design and materials
- **NEW** 5 year warranty, lifetime warranty on frame



<b>SUN-FECO2E</b>	Fusion 2 Section Electric Couch
<b>SUN-FECO2H</b>	Fusion 2 Section Hydraulic Couch
<b>SUN-FECO-LEG1</b>	Leg Supports
<b>SUN-FECO-PHB1</b>	Phlebotomy Arm (each)
<b>SUN-FECO-FSW1*</b>	Foot Switch
<b>SUN-FECO-SUP1</b>	Stirrups (pair)
<b>SUN-FECO-CHP1</b>	Head Pillow
<b>SUN-FECO-CBH1*</b>	Breathing Hole
<b>SUN-FECO-CSR*</b>	Folding Side Rails (pair)
<b>SUN-FECO-IV2*</b>	IV Pole Attachment
<b>SUN-FECO-BB*</b>	Battery Backup
<b>SUN-FECO-HEO*</b>	Electric Operated Head Section Upgrade

 <b>SUN-FECO-LEG1</b> Leg Supports	 <b>SUN-FECO-PHB1</b> Phlebotomy Arm (each)	 <b>SUN-FECO-FSW1*</b> Foot Switch	 <b>SUN-FECO-SUP1</b> Gynae Stirrups
 <b>SUN-FECO-CHP1</b> Breathing Hole	 <b>SUN-FECO-CBH1*</b> Breathing Hole	 <b>SUN-FECO-CSR*</b> Folding Side Rails (pair)	 <b>SUN-FECO-IV2*</b> IV Pole Attachment
 <b>SUN-FECO-BB*</b> Battery Backup	 <b>SUN-FECO-HEO*</b> Electric Operated Head Section Upgrade		

\* these accessories can only be fitted when ordered with couch

### anti-bacterial vinyl upholstery colours please specify when ordering



+ Where lifetime warranty on frame is stated, the cover period for the frame is extended to 15 years from the date of despatch.



FusionEco



**SUN-FECO2E**  
Fusion 2 section electric couch

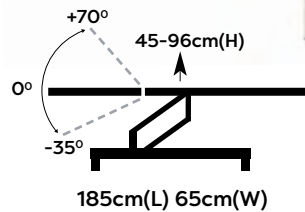

**Optional Electric Head Section**  
(electric models only)



**SUN-FECO2H**  
Fusion 2 section hydraulic couch

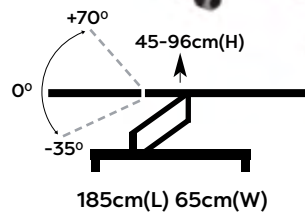

Normally delivered within 7-10 working days (\*UK Only)



Fully upholstered head sections with gas assisted adjustment



Hydraulic height adjustment

## Sunflower Fusion ECO 3 Section Couches

The new Fusion Eco couch range provides most of the functionality you would expect for our standard Fusion range at a more affordable price to suit individual budgets. Fusion Eco is simply, strong, stable, aesthetically pleasing and easy to clean.

- Electric or hydraulic height adjustment 45 - 98cm
- Maximum user weight 250kg (40st.)
- Gas strut assisted multi-position head section
- Back and leg rest adjustment +70° / -35°
- Easy to use handset (electric models only)
- Retractable positioning castors
- Adjustable height levelling foot
- Double layer density foam for support & comfort
- Luxury 65mm deep contoured upholstery
- Anti-bacterial/anti-microbial vinyl
- Anti-bacterial Vinyl - Fire (Flammability) Testing BS 7176 Medium Hazard BS 5852 : 2006 Clause 11
- Paper roll holder (supplied as standard)
- Easy clean design and materials
- **NEW** 5 year warranty, lifetime warranty on frame



<b>SUN-FECO3E</b>	Fusion 3Section Eelectric Couch
<b>SUN-FECO3H</b>	Fusion 3Section Hydraulic Couch
<b>SUN-FECO-LEG1</b>	Leg Supports
<b>SUN-FECO-PHB1</b>	Phlebotomy Arm (each)
<b>SUN-FECO-FSW1*</b>	Foot Switch
<b>SUN-FECO-SUP1</b>	Stirrups (pair)
<b>SUN-FECO-CHP1</b>	Head Pillow
<b>SUN-FECO-CBH1*</b>	Breathing Hole
<b>SUN-FECO-CSR*</b>	Folding Side Rails (pair)
<b>SUN-FECO-IV2*</b>	IV Pole Attachment
<b>SUN-FECO-BB*</b>	Battery Backup
<b>SUN-FECO-HEO*</b>	Electric Operated Head Section Upgrade
<b>SUN-FECO-FEO*</b>	Electric Operated Foot Section Upgrade

<b>SUN-FECO-LEG1</b> Leg Supports	<b>SUN-FECO-PHB1</b> Phlebotomy Arm (each)	<b>SUN-FECO-FSW1*</b> Foot Switch	<b>SUN-FECO-SUP1</b> Gynae Stirrups
<b>SUN-FECO-CHP1</b> Breathing Hole	<b>SUN-FECO-CBH1*</b> Breathing Hole	<b>SUN-FECO-CSR*</b> Folding Side Rails (pair)	<b>SUN-FECO-IV2*</b> IV Pole Attachment
<b>SUN-FECO-BB*</b> Battery Backup	<b>SUN-FECO-HEO*</b> Electric Operated Head Section Upgrade	<b>SUN-FECO-FEO*</b> Electric Operated Foot Section Upgrade	

\* these accessories can only be fitted when ordered with couch

### anti-bacterial vinyl upholstery colours please specify when ordering



+ Where lifetime warranty on frame is stated, the cover period for the fame is extended to 15 years from the date of despatch.

**sunflower**  
HEALTHCARE FURNITURE

**Fusion Eco**

5 Year Warranty  
Lifetime Warranty on Frame

**SUN-FECO3E**  
Fusion 3 section electric couch

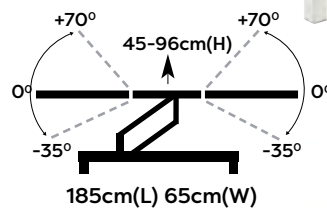

**Optional Electric Head & Foot Sections**  
(electric models only)



**SUN-FECO3H**  
Fusion 3 section hydraulic couch

Normally delivered within 7-10 working days (\*UK Only)



Fully upholstered head & foot sections with gas assisted adjustment



Hydraulic height adjustment

## Sunflower Fixed Height Reclining Phlebotomy Chairs

The new Fixed Height Reclining Treatment Chair range has been designed using our extensive knowledge to provide a trusted, ergonomic design providing comfort for the patient and comfortable patient positioning for the clinician. The chair features a robust locking bar and gas strut backrest arrangement allowing the patient to rapidly go from a seated position to head down, feet up position in only 2 movements. The leg section with locking bars is easy to adjust and gives a wide range of positions.

- 50cm Fixed height seat
- Maximum user weight 225kg (35st.)
- 50mm Locking castors for stability & easy movement (PHLEB2)
- 4 Adjustable feet (PHLEB1)
- Optional padded arm supports
- Luxury 60mm thick padded upholstery for comfort
- Self locking gas assisted back section adjustment
- Hoist clearance 13cm
- Head and foot, up or down  $-10^\circ / +10^\circ$  for patient emergencies
- One fully adjustable phlebotomy arm as standard (can be used either side)
- Double layer density foam for support & comfort
- Anti-bacterial/anti-microbial vinyl
- Anti-bacterial Vinyl - Fire (Flammability) Testing BS 7176 Medium Hazard BS 5852 : 2006 Clause 11
- Paper roll holder (supplied as standard)
- Easy clean design and materials
- **NEW** 5 year warranty



<b>SUN-PHLEB1</b>	Fixed Height Phlebotomy Chair - with adjustable feet
<b>SUN-PHLEB2</b>	Fixed Height Phlebotomy Chair - with 4 locking castors
<b>SUN-PHLEB-PHB1</b>	Additional Phlebotomy Arm (each)
<b>SUN-CHP1</b>	Head Pillow
<b>SUN-PHLEB-IV2*</b>	IV Pole Attachment
<b>SUN-PHLEB-PAS1</b>	Padded Arm Supports (each)



**SUN-PHLEB-PHB1**  
Additional Phlebotomy Arm (each)



**SUN-CHP1**  
Head Pillow

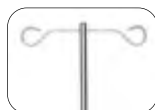

**SUN-PHLEB-IV2\***  
IV Pole Attachment



**SUN-PHLEB-PAS1**  
Padded Arm Supports (each)

\* these accessories can only be fitted when ordered with couch

### anti-bacterial vinyl upholstery colours

please specify when ordering



**SUN-PHLEB1**  
Fixed Height Phlebotomy Chair with adjustable feet

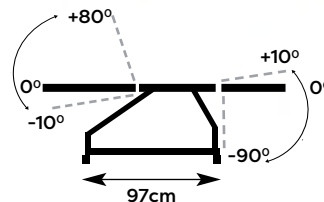

170cm(L) 65cm(W) 50cm(H)



**SUN-PHLEB2**  
Fixed Height Phlebotomy Chair with 4 locking castors

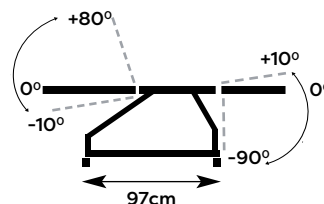

170cm(L) 65cm(W) 50cm(H)



In emergency situations for patient recovery chair goes head down  $-10^\circ$  and foot up  $+10^\circ$



## Sunflower Fixed Height Reclining Treatment Chairs

The new Fixed Height Reclining Treatment Chair range has been designed using our extensive knowledge to provide a trusted, ergonomic design providing comfort for the patient and comfortable patient positioning for the clinician. The chair features a robust locking bar and gas strut backrest arrangement allowing the patient to rapidly go from a seated position to head down, feet up position in only 3 movements. The split leg design with locking bars is easy to adjust and gives a wide range of positions.

- 50cm Fixed height seat
- Maximum user weight 225kg (35st.)
- 50mm Locking castors for stability & easy movement (TREA2)
- 4 Adjustable feet (TREA1)
- Split leg design with locking bars for leg positioning
- 2 Adjustable/removable padded arm supports
- Luxury 60mm thick padded upholstery for comfort
- Self locking gas assisted back section adjustment
- Hoist clearance 13cm
- Head and foot, up or down  $-10^\circ / +10^\circ$  for patient emergencies
- Double layer density foam for support & comfort
- Anti-bacterial/anti-microbial vinyl
- Anti-bacterial Vinyl - Fire (Flammability) Testing BS 7176 Medium Hazard BS 5852 : 2006 Clause 11
- Paper roll holder (supplied as standard)
- Easy clean design and materials
- **NEW** 5 year warranty



**SUN-TREA1**  
Fixed Height Treatment Chair with adjustable feet

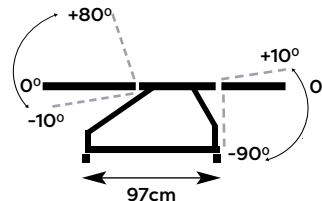

170cm(L) 65cm(W) 50cm(H)



In emergency situations for patient recovery chair goes head down  $-10^\circ$  and foot up  $+10^\circ$

<b>SUN-TREA1</b>	Fixed Height Treatment Chair - with adjustable feet
<b>SUN-TREA2</b>	Fixed Height Treatment Chair - with 4 locking castors
<b>SUN-TREA-PHB1</b>	Additional Phlebotomy Arm (each)
<b>SUN-CHP1</b>	Head Pillow
<b>SUN-TREA-IV2*</b>	IV Pole Attachment



**SUN-TREA2**  
Fixed Height Treatment Chair with 4 locking castors

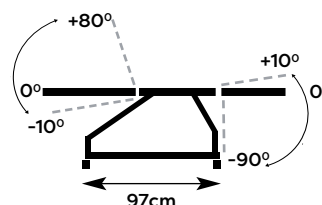

170cm(L) 65cm(W) 50cm(H)



Split leg design with locking bars for leg positioning



**SUN-TREA-PHB1** Phlebotomy Arm (each)  
**SUN-CHP1** Head Pillow  
**SUN-TREA-IV2\*** IV Pole Attachment

\* these accessories can only be fitted when ordered with couch

### anti-bacterial vinyl upholstery colours please specify when ordering



# Sunflower Practitioner Deluxe Examination Couches

Stylish, practical and comfortable, Practitioner Couches make examination and treatment procedures easier, combined with contemporary aesthetics.

- 4 Drawer and cabinet finishes
- Maximum user weight 165kg (26st.)
- Multi-position self locking backrest
- Single layer density foam for support & comfort
- Luxury 65mm deep contoured upholstery
- Anti-bacterial/anti-microbial vinyl
- Anti-bacterial Vinyl - Fire (Flammability) Testing BS 7176 Medium Hazard BS 5852 : 2006 Clause 11
- Paper roll holder (supplied as standard)
- Durable silver epoxy coated frame
- 60cm diameter legs for stability with adjustable feet for uneven floors
- Choice of integrated storage solutions
- Easy clean design and materials
- **NEW** 5 year warranty



**SUN-MEC1**  
Practitioner deluxe examination couch with optional pull-out work surface, drawer units, mobile storage unit, leg supports, step and head pillow

<b>SUN-MEC1</b>	Practitioner Deluxe Examination Couch
<b>SUN-CBH1*</b>	Breathing Hole
<b>SUN-CHP1</b>	Head Pillow
<b>SUN-LEG1*</b>	Leg Supports (pair)
<b>SUN-CDT2</b>	Drawer Insert (each)
<b>SUN-STP1</b>	Single Tier Step (oval)
<b>SUN-STP2</b>	Double Tier Step (oval)
<b>SUN-STP3</b>	Single Tier Step (rectangular)
<b>SUN-PB1*</b>	Pull-out Basket for Storage Unit
<b>SUN-CPS2W</b>	Pull-out Work Surface - White Finish
<b>SUN-CPS2M</b>	Pull-out Work Surface - Maple Finish
<b>SUN-CPS2T</b>	Pull-out Work Surface - Titanium Finish
<b>SUN-CPS2B</b>	Pull-out Work Surface - Beech Finish
<b>SUN-CMU1W</b>	Mobile Storage Unit (with locking door) - White Finish
<b>SUN-CMU1M</b>	Mobile Storage Unit (with locking door) - Maple Finish
<b>SUN-CMU1T</b>	Mobile Storage Unit (with locking door) - Titanium Finish
<b>SUN-CMU1B</b>	Mobile Storage Unit (with locking door) - Beech Finish
<b>SUN-MCD1W</b>	Single Drawer Unit - White Finish
<b>SUN-MCD1M</b>	Single Drawer Unit - Maple Finish
<b>SUN-MCD1T</b>	Single Drawer Unit - Titanium Finish
<b>SUN-MCD1B</b>	Single Drawer Unit - Beech Finish

 <b>SUN-CBH1*</b> Breathing Hole	 <b>SUN-CHP1</b> Head Pillow	 <b>SUN-LEG1*</b> Leg Supports (pair)	 <b>SUN-CDT2</b> Drawer Insert (each)
 <b>SUN-PB1*</b> Pull-out Basket for Storage Unit	 <b>SUN-CPS2</b> Pull-out Work Surface	 <b>SUN-CMU1</b> Mobile Storage Unit (with locking door)	 <b>SUN-MCD1</b> Single Drawer Unit

\* these accessories can only be fitted when ordered with couch

## anti-bacterial vinyl upholstery colours

please specify when ordering



White (high gloss) cabinet finish



Titanium (high gloss) cabinet finish



Beech effect cabinet finish



Maple effect cabinet finish

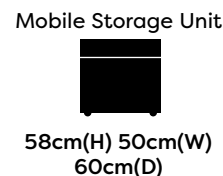
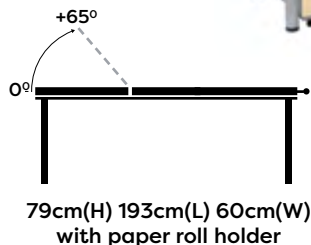

# Sunflower Specialist Treatment Couch Systems

Combining functionality with storage and comfort, Specialist Couches assist in making examination and treatment procedures easier and more efficient. Ideal for use in all medical environments.

- 4 Cabinet finishes
- Maximum user weight 165kg (26st.)
- Available in 2 or 3 section upholstery
- Multi-position self locking back & foot rests
- Single layer density foam for support & comfort
- Luxury 65mm deep contoured upholstery
- Anti-bacterial/anti-microbial vinyl
- Anti-bacterial Vinyl - Fire (Flammability) Testing BS 7176 Medium Hazard BS 5852 : 2006 Clause 11
- Paper roll holder (supplied as standard)
- 2 Pull-out work surfaces
- Cupboards include pull-out work surface and basket, shelf and lock
- Locking doors supplied with 2 keys
- Durable silver epoxy coated frame
- Cabinets supplied fully assembled
- Easy clean design and materials
- **NEW** 5 year warranty



**SUN-CS1-3S**  
Specialist treatment couch system with 2 drawerline units, 1 drawer pack, 3 section upholstery and optional head pillow

### 3 Section Upholstery

- SUN-CS1W-3S** Specialist Couch System with 2 Drawline Unit & 1 Drawer Pack - White
- SUN-CS1M-3S** Specialist Couch System with 2 Drawline Unit & 1 Drawer Pack - Maple
- SUN-CS1T-3S** Specialist Couch System with 2 Drawline Unit & 1 Drawer Pack - Titanium
- SUN-CS1B-3S** Specialist Couch System with 2 Drawline Unit & 1 Drawer Pack - Beech

### 2 Section Upholstery

- SUN-CS1W** Specialist Couch System with 2 Drawline Unit & 1 Drawer Pack - White
- SUN-CS1M** Specialist Couch System with 2 Drawline Unit & 1 Drawer Pack - Maple
- SUN-CS1T** Specialist Couch System with 2 Drawline Unit & 1 Drawer Pack - Titanium
- SUN-CS1B** Specialist Couch System with 2 Drawline Unit & 1 Drawer Pack - Beech

- SUN-CBH1\*** Breathing Hole
- SUN-CHP1** Head Pillow
- SUN-LEG1\*** Leg Supports (pair)
- SUN-CDT1** Drawer Insert (each)
- SUN-STP1** Single Tier Step (oval)
- SUN-STP2** Double Tier Step (oval)
- SUN-STP3** Single Tier Step (rectangular)



\* these accessories can only be fitted when ordered with couch

### anti-bacterial vinyl upholstery colours

please specify when ordering



White (high gloss) cabinet finish



Titanium (high gloss) cabinet finish



Beech effect cabinet finish



Maple effect cabinet finish

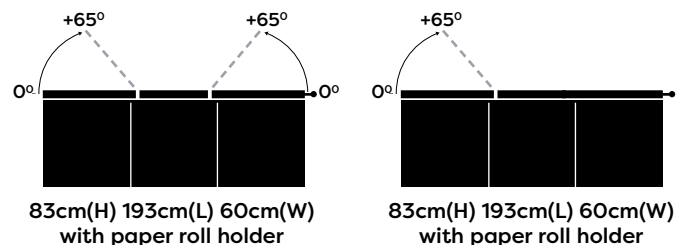

# Sunflower Specialist Treatment Couch Systems



B

Combining functionality with storage and comfort, Specialist Couches assist in making examination and treatment procedures easier and more efficient. Ideal for use in all medical environments.

- 4 Cabinet finishes
- Maximum user weight 165kg (26st.)
- Available in 2 or 3 section upholstery
- Multi-position self locking back & foot rests
- Single layer density foam for support & comfort
- Luxury 65mm deep contoured upholstery
- Anti-bacterial/anti-microbial vinyl
- Anti-bacterial Vinyl - Fire (Flammability) Testing BS 7176 Medium Hazard BS 5852 : 2006 Clause 11
- Paper roll holder (supplied as standard)
- 2 Pull-out work surfaces
- Cupboards include pull-out work surface and basket, shelf and lock
- Locking doors supplied with 2 keys
- Durable silver epoxy coated frame
- Cabinets supplied fully assembled
- Easy clean design and materials
- **NEW** 5 year warranty



### 3 Section Upholstery

- SUN-CS3W-3S** Specialist Couch System with 1 Drawline Unit & 1 Drawer Pack - White
- SUN-CS3M-3S** Specialist Couch System with 1 Drawline Unit & 1 Drawer Pack - Maple
- SUN-CS3T-3S** Specialist Couch System with 1 Drawline Unit & 1 Drawer Pack - Titanium
- SUN-CS3B-3S** Specialist Couch System with 1 Drawline Unit & 1 Drawer Pack - Beech

### SUN-CS3-3S

Specialist treatment couch system with 1 drawline unit, 1 drawer pack, 3 section upholstery and optional head pillow

### 2 Section Upholstery

- SUN-CS3W** Specialist Couch System with 1 Drawline Unit & 1 Drawer Pack - White
- SUN-CS3M** Specialist Couch System with 1 Drawline Unit & 1 Drawer Pack - Maple
- SUN-CS3T** Specialist Couch System with 1 Drawline Unit & 1 Drawer Pack - Titanium
- SUN-CS3B** Specialist Couch System with 1 Drawline Unit & 1 Drawer Pack - Beech

- SUN-CBH1\*** Breathing Hole
- SUN-CHP1** Head Pillow
- SUN-LEG1\*** Leg Supports (pair)
- SUN-CDT1** Drawer Insert (each)
- SUN-STP1** Single Tier Step (oval)
- SUN-STP2** Double Tier Step (oval)
- SUN-STP3** Single Tier Step (rectangular)



White (high gloss) cabinet finish



Titanium (high gloss) cabinet finish



Beech effect cabinet finish



Maple effect cabinet finish



			
<b>SUN-CBH1*</b> Breathing Hole	<b>SUN-CHP1</b> Head Pillow	<b>SUN-LEG1*</b> Leg Supports (pair)	<b>SUN-CDT2</b> Drawer Insert (each)
			
<b>SUN-STP1</b> Single Tier Step (oval)	<b>SUN-STP2</b> Double Tier Step (oval)	<b>SUN-STP3</b> Single Tier Step (rectangle)	

\* these accessories can only be fitted when ordered with couch

### anti-bacterial vinyl upholstery colours

please specify when ordering

black	grey	beige	primrose	red wine	lilac	navy	mid blue
sky blue	cool blue	green	mint	white			

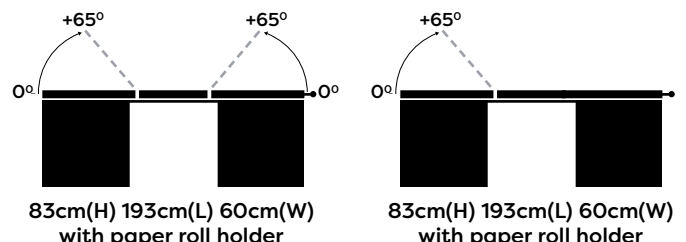

Furniture

# Sunflower Colenso Examination Couches

Simple, strong and durable, Colenso Couches are designed for everyday general healthcare, providing comfort with contemporary design.

- Maximum user weight 165kg (26st.)
- Multi-position self locking backrest
- Single layer density foam for support & comfort
- Luxury 65mm deep contoured upholstery
- Anti-bacterial/anti-microbial vinyl
- Anti-bacterial Vinyl - Fire (Flammability) Testing BS 7176 Medium Hazard BS 5852 : 2006 Clause 11
- Paper roll holder (supplied as standard)
- Durable silver epoxy coated frame
- Stylish 60cm diameter legs for stability
- 4 Non marking leg protectors
- Easy clean design and materials
- **NEW** 5 year warranty



SUN-MEC2 Colenso examination couch with optional head pillow and couch step

SUN-MEC2	Colenso Examination Couch
SUN-CBH1*	Breathing Hole
SUN-CHP1	Head Pillow
SUN-LEG1*	Leg Supports (pair)
SUN-STP1	Single Tier Step (oval)
SUN-STP2	Double Tier Step (oval)
SUN-STP3	Single Tier Step (rectangular)
SUN-MPT51	Vista 15 Under Couch Trolley
SUN-MPT52	Vista 15 Under Couch Trolley
SUN-MPT53	Vista 15 Under Couch Trolley



 SUN-CBH1* Breathing Hole	 SUN-CHP1 Head Pillow	 SUN-LEG1* Leg Supports (pair)	 SUN-STP1 Single Tier Step (oval)
 SUN-STP2 Double Tier Step (oval)	 SUN-STP3 Single Tier Step (rectangle)	 SUN-MPT51 Vista 15 Under Couch Trolley	 SUN-MPT52 Vista 15 Under Couch Trolley
 SUN-MPT53 Vista 15 Under Couch Trolley	* these accessories can only be fitted when ordered with couch		



SUN-MEC2 Colenso examination couch with optional Vista 15 under couch trolley

## anti-bacterial vinyl upholstery colours

please specify when ordering

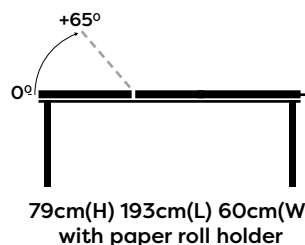

## Sunflower Alberti Rest Couches

Designed for resting, recovery or where a reduced height application is required, Alberti Couches are strong, durable, easy to clean while being exceptionally comfortable.



- Low height only 50cm high
- Maximum user weight 165kg (26st.)
- Multi-position self locking backrest
- Single layer density foam for support & comfort
- Luxury 65mm deep contoured upholstery
- Anti-bacterial/anti-microbial vinyl
- Anti-bacterial Vinyl - Fire (Flammability) Testing BS 7176 Medium Hazard BS 5852 : 2006 Clause 11
- Paper roll holder (supplied as standard)
- Durable silver epoxy coated frame
- Stylish 60cm diameter legs for stability
- 4 adjustable legs for uneven floors
- Easy clean design and materials
- **NEW** 5 year warranty

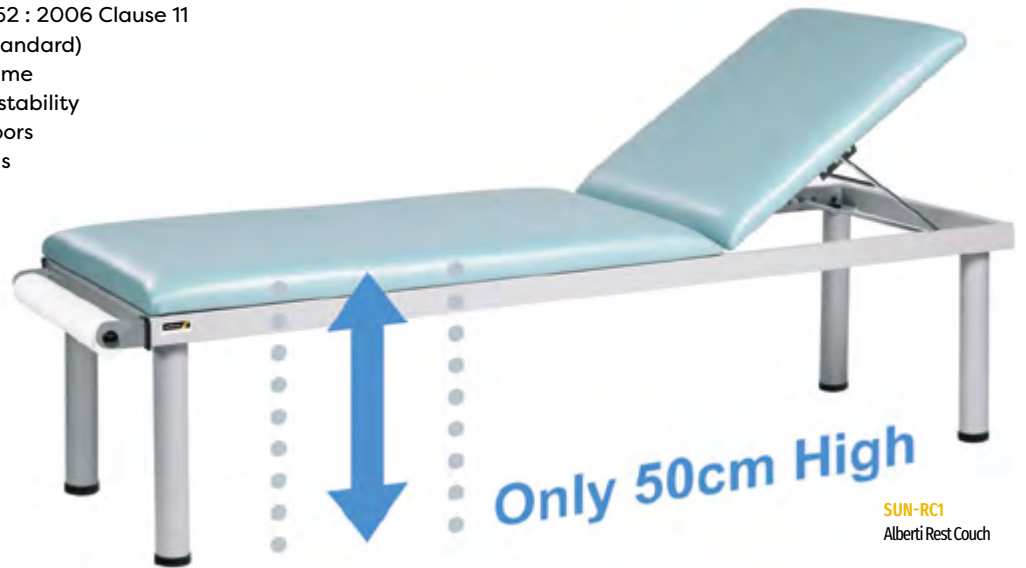

Only 50cm High

SUN-RC1  
Alberti Rest Couch

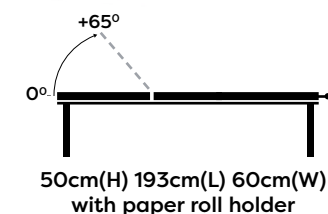

SUN-RC1	Alberti Rest Couch
SUN-CBH1*	Breathing Hole
SUN-CHP1	Head Pillow
SUN-STP1	Single Tier Step (oval)
SUN-STP2	Double Tier Step (oval)
SUN-STP3	Single Tier Step (rectangle)



SUN-CBH1\*  
Breathing Hole



SUN-CHP1  
Head Pillow



SUN-STP1  
Single Tier Step (oval)



SUN-STP2  
Double Tier Step (oval)



SUN-STP3  
Single Tier Step (rectangle)

\* these accessories can only be fitted when ordered with couch

### anti-bacterial vinyl upholstery colours

please specify when ordering



## Doherty Examination Chairs

- 10-year guarantee on frame
- Express 5-day delivery service (Delivered assembled)
- Extendable leg section
- Electrically operated variable height range easy-use handset
- 'Easi Lift' gas assisted backrest and foot section
- Distinctive wipe-clean Doherty-style thick padded upholstery with rounded corners for comfort and hygiene
- 5 attractive modern colour ways to match environments
- Dual sided operation for flexibility of positioning
- Phlebotomy arms and paper roll holders available
- Simple leveling mechanism for uneven floors
- Twin braked castors for ease of movement
- Maximum user weight 177kgs (28 stone)
- Height range: 49-88cm
- Width (exc. Arms) 54.5cm
- Flattened Length: 183cm (210cm space for height movement)



HCF670

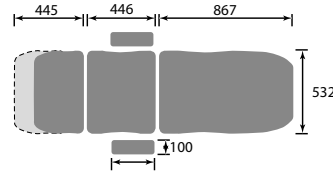

HCF672

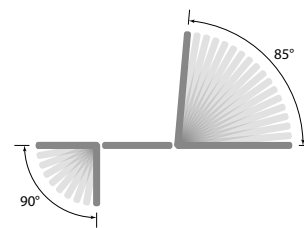
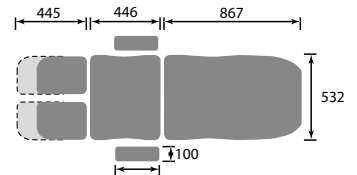

HCF670	Doherty Phlebotomy Chair
HCF671	Doherty Plebotomy Chair with Breathing Hole
HCF675	Doherty Phlebotomy Arms
HCF672	Doherty Variable Height Treatment Chair
HCF673	Doherty Variable Height Treatment Chair with Breathing Hole
HCF676	Doherty Paper Roll Holder

### Colour Options:

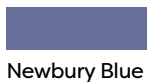

Newbury Blue



Apple Green



Slate Grey



Storm Blue



Midnight Black

## Doherty Plinths

The Doherty 2 and 3 Section Plinths have been developed specifically for applications throughout the modern GP practice.

- 10-year guarantee on frame
- Express 5-day delivery service (Delivered assembled)
- Electrically operated height range from 460mm to 850mm
- Easy lift gas assisted backrest and foot section
- New rear castors for ease of movement
- Maximum user weight 160kgs (25 stone)
- Breathing hole and paper role holders fitted as standard
- Dual sided operation
- Distinctive Doherty style upholstery with rounded corners for hygiene and cleanliness
- Twin retractable castors for ease of movement
- Attractive white epoxy coating with Biocote

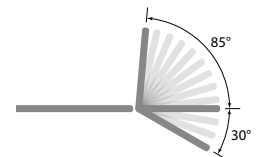

HCF720	Doherty 2 Section Plinth
HCF721	Doherty 3 Section Plinth

### Plinth Accessories:

HCF722	Doherty Universal Accessory Bracket - Pair
HCF723	Doherty Side Rails - Pair
HCF724	Doherty Knee Troughs - Pair
HCF725	Doherty Phlebotomy Arms - Pair
HCF726	Doherty Lithotomy Stirrups - Pair
HCF727	Doherty Foot pedal

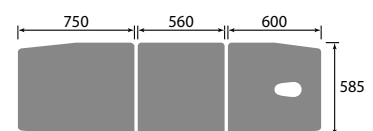
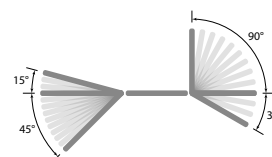

### Colour Options:

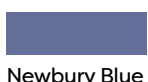

Newbury Blue



Apple Green



Slate Grey



Storm Blue



Midnight Black

## Doherty Winchester Couch

- Extremely reliable self locking adjustable backrest
- Unstitched, rounded upholstery corners for hygiene
- 5cm thick CMHR foam top for patient comfort
- Durable white epoxy coating
- Unique paper roll holder supplied as standard that can be fitted either within the couch frame or externally
- Easy to clean, hygienic, epoxy coated white frame
- Available in 11 modern colour upholstery options
- Maximum user weight 160kg/25stone
- **Dimensions:** 80 x 70.5cm x 184-194cm (Paper roll int/etx.)
- **Weight:** 40kg

**HCF532** Doherty Winchester Couch

**Available Colour Options:**



Newbury Blue



Apple Green



Slate Grey



Storm Blue



Midnight Black

The Winchester couch has the option of including a drawer system, allowing the user to select numerous combinations of drawer spaces.

Attractive and durable mild steel white epoxy coated finish with Biocote® Installation.

**HCF728** Winchester Couch Single Drawer – Drawer Only



**Drawers only, Couch not included**  
**For Couch please see above**

## Doherty Purley Couch

- Up to three optional drawer units can be fitted
- 50mm thick CMHR foam top for patient comfort
- Available in your choice of 5 standard upholstery colours
- Quick and easy to assemble – tools also supplied
- Durable, magnolia epoxy coating with Biocote®
- Unstitched rounded upholstery corners to ensure hygiene and couch cleanliness
- 1-year standard manufacturer warranty
- Self locking, multi-position adjustable backrest
- Maximum user weight 160kg (25st)
- **Dimensions:** 76 x 61 x 183cm
- **Weight:** 34kg



**HCF286** Doherty Purley Couch

**HCF287** Doherty Purley Single Drawer – Drawer Only

**Available Colour Options:**



Newbury Blue



Apple Green



Slate Grey



Storm Blue



Midnight Black

## Doherty Salisbury Couch

- Electrically controlled, multi-function, variable height couch
- Swing away side rails and paper roll holder fitted as standard
- Developed specifically for the modern GP practice and hospital environment
- 4 braked/swivel castors for manoeuvrability and safety
- Adjustable backrest section with optional breathing hole
- 3-year warranty (1 year parts/labour, 2 year parts only)
- Available in your choice of 5 standard upholstery colours
- Maximum user weight 160kg (25st)
- **Dimensions:** 76 x 61 x 183cm
- **Weight:** 34kg



**HCF662** Salisbury Couch including Side Rails

**HCF663** Salisbury Steer Bar



## Doherty Enfield Couch

The Enfield fixed height couch from Doherty is a best-selling medical examination couch. Manufactured from Epoxy coated stainless steel, this simple to assemble budget couch provides excellent quality and value.

- A budget-priced examination couch of excellent quality
- 76cm fixed seat height
- The UK's best selling fixed examination couch
- Epoxy-coated square tubed steel frame and legs in magnolia with Bio-Cote antibacterial coating
- Black upholstery only with white epoxy coated finish
- Couch supplied complete with paper roll holder
- Quick and easy to assemble – tools also supplied
- Features a self-locking, multi-position adjustable backrest
- **Maximum user weight:** 160kg (25st)
- **Dimensions:** 76 x 61 x 185cm
- **Weight:** 32kg

**HCF050** Doherty Enfield Fixed Height Couch



## Doherty Bariatric Plinths

The new Doherty two and three Section Plinths have been specifically developed for use with larger patients. They will, however, also be very useful in many Physiotherapy applications where a larger surface area and weight bearing capability is required.

The exceptionally wide surface of the two Section Plinth makes it particularly suitable for use as a Neuro or Physiotherapy plinth.

- **10 Year guarantee on frame**
- **3-year warranty (1 year parts/labour, 2 year parts only)**
- Electrical operated variable height (used from either side)
- Electrically operated backrest section
- Breathing hole and paper roll holder fitted as standard
- Exceptionally wide surface makes this plinth particularly suitable for use also as a Neuro or Physiotherapy plinth
- Maximum user weight 320kgs (50st)
- Distinctive Doherty style upholstery with rounded corners
- Fitted with 4 large castors for ease of movement and a central locking brake system giving added safety
- Delivered fully assembled

**HCF892** Doherty 2 Section Bariatric Plinth

**HCF892.1** Doherty Bariatric Plinth Phlebotomy Arms

**HCF892.2** Doherty Bariatric Plinth Side Rails

**HCF893** Doherty 3 Section Bariatric Plinth

**HCF892.1** Doherty Bariatric Plinth Phlebotomy Arms

**HCF892.2** Doherty Bariatric Plinth Side Rails

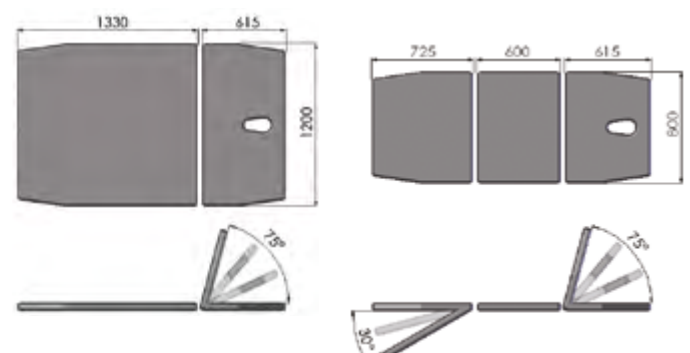

Available Colour Options:



Newbury Blue

Midnight Black



**drive**  
DeVilbiss  
HEALTHCARE

2 Year  
Warranty

## Bariatric II Dynamic Mattress System

Heavier patients require a dynamic support surface that fulfills their requirements. The Bariatric II Mattress system assists with the pressure distribution and is designed for the plus-size patient.

- **2 year warranty (parts and labour)**
- **Supplied with nylon carry bag**
- **Maximum user weight 318Kg (50 stone)**
- 3 cell alternating dynamic pressure therapy, full mattress replacement system.
- Easy to use digital control system with varying modes
- Automatic return from Static to Alternating mode after 1 hour
- Unique Nurse Mode lifts pressure quickly to highest setting for 20 minutes before returning it to original pressure setting
- Easy to use Transport mode blanking plate
- Visible and audible alarm for low or high pressure, alternating failure and power down.
- Top hinge, positioned to aid profiling, reduces pinching of cells
- Two way stretch, waterproof/vapour-permeable top cover.
- Unique twin compressor control for faster, reliable inflation
- Easy Glide material incorporated into underside of mattress

### Specification:

- **Dimensions:** 115 x 200 x 28cm
- **Risk Factor:** At High Risk
- **Cycle Time:** 12 minutes
- **Seams:** Welded

**HCF364** Bariatric II Dynamic Mattress System

**HDA147** Replacement Pump for Bariatric II Dynamic Mattress System

## Bariatric VE Mattress

The Sidhil Acclaim Bariatric VE Foam Pressure Relief Mattress is designed for larger patients, and is made with multiple layers of visco-elastic foam which is reinforced with dense side walls to provide both pressure relief and stability for users at a high risk.

Bariatric patients will require a higher level of support than standard mattresses can provide, and this is especially true if they are at risk of pressure sores.

- Provides pressure relief suitable for those at high risk of pressure sore development
- Two-way turning capability increases durability by evenly distributing wear and tear
- A static turning support mattress (2 ways head to foot)
- Visco elastic layered foam pressure reducing mattress
- A high risk mattress which has been engineered specifically to be used in conjunction with the Sidhil Bradshaw Bariatric bed
- Supports patient transfers
- Unique zip locate indicator
- X-Ray translucent cover available on request

### Specification:

- **Maximum user weight:** 320kg (50 stone)
- **Dimensions (LxWxD):** 203.2 x 112.8 x 16.6cm
- **Product weight:** 20kg
- **Turning cycle:** 2 way

**HCF365** Acclaim Bariatric VE Mattress



**drive**  
DeVilbiss  
HEALTHCARE

2 Year  
Warranty

## Medi-Plinth Chairs and Stools

Medi-plinth offer a range of chairs and stools designed in common variants such as: operator, laboratory or saddle. In addition to this they also offer standard quad-leg and phlebotomy chairs.

Chairs are upholstered in our standard range of 14 colours. Durable, comfortable vinyl which inhibits MRSA (3352 Methicillin resistant to Staphylococcus Aurus) and is fire retardant. Bio-Pruf treated to resist the mould growth, mildew and odour causing microbes.

Our full range of chairs and stools are available with a standard one year manufacturer warranty.



**SAD01 Saddle Stool**

Lowest seat position: **42.5cm**  
Highest seat position: **56cm**  
Maximum load: **150kg**



**WCS1PHL1 Phlebotomy Chair**

Seat height: **50cm**  
Chair pad width: **46cm**  
Max Load: **114kg**



**OCS1A Operators Chair**

Lowest seat position: **42.5cm**  
Highest seat position: **50cm**  
Maximum load: **150kg**



**LAB1CHFR Lab chair with foot ring**

Lowest seat position: **61cm**  
Highest seat position: **91cm**  
Maximum load: **150kg**

### Saddle Stools

<b>SAD01</b>	Saddle Stool
<b>SAD01FR</b>	Saddle Stool with Foot Ring
<b>SAD01BKR</b>	Saddle Stool with Backrest
<b>SAD01BKFR</b>	Saddle Stool with Foot Ring & Backrest
<b>SAD01PU</b>	Saddle Stool Black PU

### Operators Chairs

<b>OCS1</b>	Operators Chair
<b>OCS1A</b>	Operators Chair with Arms
<b>OCS1AFR</b>	Operators Chair with Arms with Foot Ring
<b>OCS1FR</b>	Operators Chair with Foot Ring

### Operators Stools

<b>OSS1</b>	Operators Stool
<b>OSS1FR</b>	Operators Stool with Foot Ring
<b>OSS1PU</b>	Operators Stool Black PU

### Operators Laboratory Chairs and Stools

<b>LAB1</b>	Laboratory Stool
<b>LAB1FR</b>	Laboratory Stool with Foot Ring
<b>LAB1CHAFR</b>	Laboratory Chair with Arms & Foot Ring
<b>LAB1CHFR</b>	Laboratory Chair with Foot Ring without Arms

### Other Chairs

<b>WCS1</b>	Chrome Frame Waiting Room Chair
<b>WCS1A</b>	Chrome Frame Waiting Room Chair with Arm Rests
<b>WCS1PHL1</b>	Chrome Frame Phlebotomy Chair (1x Phlebotomy Arm – This arm can be attached to either side of the chair)



**LAB1FR Lab stool**

Lowest seat position: **61cm**  
Highest seat position: **86cm**  
Maximum load: **150kg**



**OSS1 Operators Stool**

Lowest seat position: **45cm**  
Highest seat position: **59cm**  
Maximum load: **150kg**

### MRSA resistant anti bacterial & fire retardant vinyl colours:

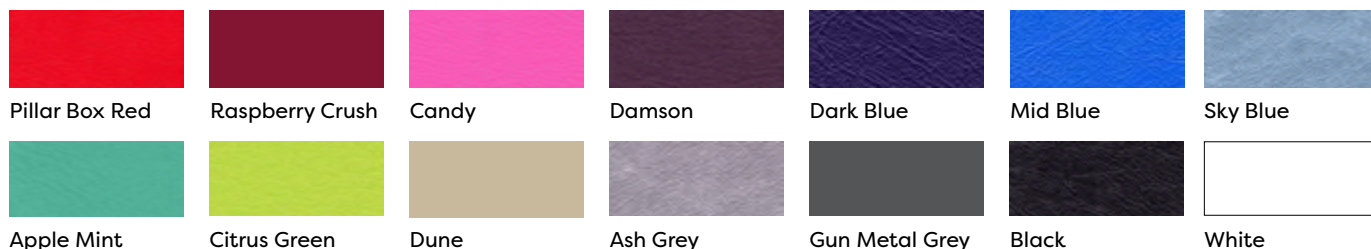

## Sunflower Operator Chairs

Adjustable for support and comfort, Operator Chairs are designed for everyday general healthcare use, therefore are comfortable, strong, durable and easy to clean.

- Maximum user weight 110kg (17st.)
- Anti-bacterial/anti-microbial vinyl
- Comfortable padded seat and back
- Anti-bacterial Vinyl - Fire (Flammability) Testing BS 7176 Medium Hazard BS 5852 : 2006 Clause 11
- 40mm Deep foam for support and comfort
- Hygienic rounded corners
- Strong and durable ergonomic arms (CHA2 & CHA4)
- Adjustable height chrome foot ring provides leg support (CHA3, CHA4 & CHA5)
- Gas-assisted height adjustment
- Five castor base for stability and manoeuvrability
- Glides reduce lateral movement (CHA5 only)
- 42 - 57cm Height Range (Sun-CHA1 & CHA2)
- 48 - 68cm Height Range (Sun-CHA3 & CHA4)
- 55 - 81cm Height Range (Sun-CHA5)
- Easy clean design and materials
- **NEW** 5 year warranty

**sunflower**  
HEALTHCARE FURNITURE



SUN-CHA1 Gas Lift Chair



SUN-CHA2 Gas Lift Chair with Arms



SUN-CHA3 Gas Lift Chair & Foot Ring



SUN-CHA4 Gas Lift Chair with Arms & Foot Ring



SUN-CHA5 High Level Gas Lift Chair & Foot Ring

<b>SUN-CHA1</b>	Gas Lift Chair
<b>SUN-CHA2</b>	Gas Lift Chair with Arms
<b>SUN-CHA3</b>	Gas Lift Chair with Foot Ring
<b>SUN-CHA4</b>	Gas Lift Chair with Arms and Foot Ring
<b>SUN-CHA5</b>	High Level Gas Lift Chair, Foot Ring and Glides

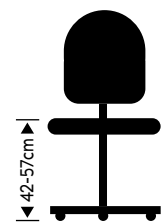

Sun-CHA1  
Seat 46cm(W) 43cm(D)  
Base 60cm Ø

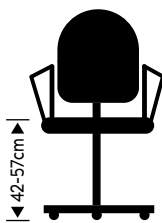

Sun-CHA2  
Seat 46cm(W) 43cm(D)  
Width with arms 60cm  
Base 60cm Ø

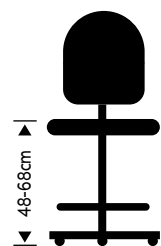

Sun-CHA3  
Seat 46cm(W) 43cm(D)  
Foot ring 46cm Ø  
Base 60cm Ø

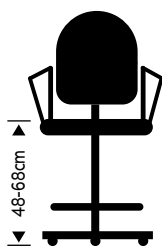

Sun-CHA4  
Seat 46cm(W) 43cm(D)  
Width with arms 60cm  
Foot ring 46cm Ø  
Base 60cm Ø

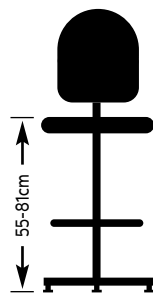

Sun-CHA5  
Seat 46cm(W) 43cm(D)  
Foot ring 46cm Ø  
Base 60cm Ø

### anti-bacterial vinyl upholstery colours

please specify when ordering



# Sunflower Examination Stools

Designed for everyday general healthcare use, Examination Stools can be static or mobile, are simple to adjust and comfortable, while being strong, durable and easy to clean.

- Maximum user weight 110kg (17st.)
- Anti-bacterial/anti-microbial vinyl
- Anti-bacterial Vinyl - Fire (Flammability) Testing BS 7176 Medium Hazard BS 5852 : 2006 Clause 11
- Comfortable padded back rest (STO4, STO5 & STO6)
- Luxury 65mm deep upholstery
- 2 layer foam for support and comfort
- Adjustable height chrome foot ring provides leg support (STO3, STO3-GLIDES, STO5 & STO6)
- Gas-assisted height adjustment
- Five castor base for stability and manoeuvrability
- Glides reduce lateral movement (STO2-GLIDES & STO3-GLIDES)
- 42 - 58cm Height Range (STO2, STO4 & STO6)
- 39 - 55cm Height Range (STO2-GLIDES)
- 51 - 69cm Height Range (STO3)
- 48 - 66cm Height Range (STO3-GLIDES)
- 42 - 69cm Height Range (STO3)
- 53 - 79cm Height Range (STO5)
- Easy clean design and materials
- **NEW** 5 year warranty



SUN-STO2 Gas Lift Stool



SUN-STO3 Gas Lift Stool with Foot Ring



SUN-STO4 Gas Lift Stool with Back Rest



SUN-STO5 High Level Gas Lift Stool with Back Rest, Foot Ring and Glides



JN-STO2-GLIDES Gas Lift Stool with Glides



SUN-STO3-GLIDES Gas Lift Stool with Foot Ring and Glides



SUN-STO6 Gas Lift Stool with Back Rest and Foot Stool

<b>SUN-STO2</b>	Gas Lift Stool
<b>SUN-STO2-GLIDES</b>	Gas Lift Stool with Glides
<b>SUN-STO3</b>	Gas Lift Stool with Foot Ring
<b>SUN-STO3-GLIDES</b>	Gas Lift Stool with Foot Ring and Glides
<b>SUN-STO4</b>	Gas Lift Stool with Back Rest
<b>SUN-STO5</b>	High Level Gas Lift Stool with Back Rest, Foot Ring and Glides
<b>SUN-STO6</b>	Gas Lift Stool with Back Rest and Foot Ring

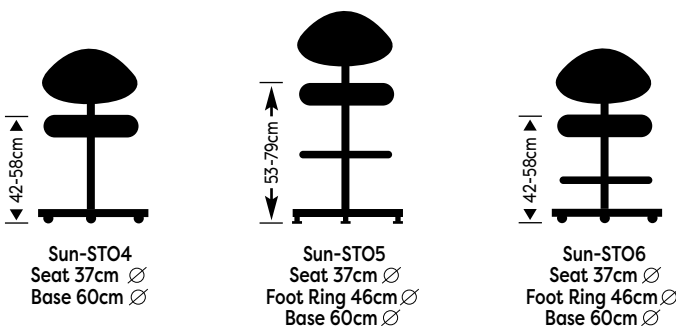
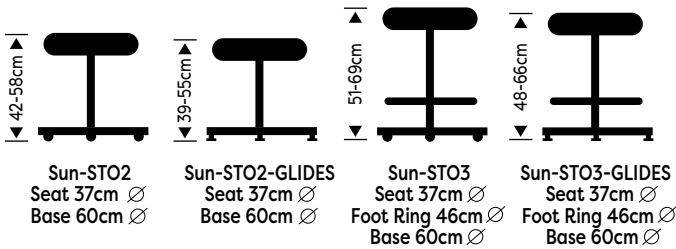

## anti-bacterial vinyl upholstery colours

please specify when ordering



## Sunflower Base, Wall & Corner Cabinets

Aesthetically designed, contemporary range of modular cabinetry incorporating wall, base, corner and sink units finished in high gloss white. Easy to clean, adjustable shelves and locks as standard.

- Quality, 18mm MFC carcass with 2mm edging
- Locking doors supplied with 2 keys
- Contemporary door and drawer profile
- Stylish flush fitting handles
- 38mm deep "Dark Grey" laminate work top (beech finish)
- 38mm deep "Crystal White" laminate work top (white finish)
- Base cabinets have one adjustable shelf, wall cabinets have two
- Base cabinets can be combined and supplied with a one piece work top in lengths of up to 4.1m.
- Cut to length worktop can be supplied upon request
- Easy clean design and materials
- Supplied fully assembled
- **NEW** 5 year warranty



**Sun-BU8 30cm Base Cabinet**

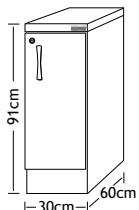

**Sun-BU1 50cm Base Cabinet**

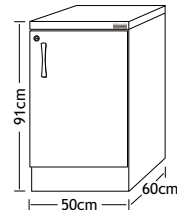

**Sun-BU2 50cm Drawerline Cabinet**

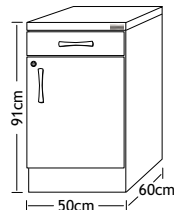

**Sun-BU3 50cm 5 Drawer Pack**

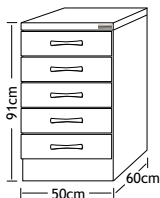

**Sun-BU4 100cm Base Cabinet**

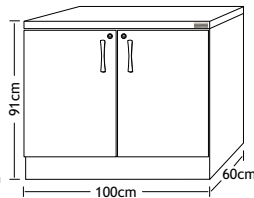

**Sun-BU5 100cm Drawerline Cabinet**

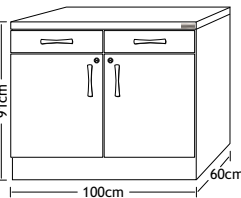

**Sun-BU6 100cm Sink Cabinet (excludes sink)**

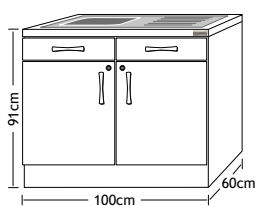

**Sun-BU7 L-Shaped Corner Base Cabinet**

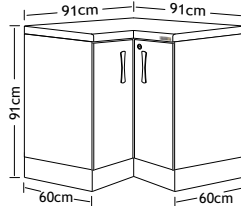

Also available in 40cm, 60cm and 80cm widths

### BASE CABINETS

<b>SUN-BU8</b>	30cm Base Cabinet
<b>SUN-BU1</b>	50cm Base Cabinet
<b>SUN-BU2</b>	50cm Drawerline Cabinet
<b>SUN-BU3</b>	50cm 5 Drawer Pack (without locks)
<b>SUN-BU4</b>	100cm Base Cabinet
<b>SUN-BU5</b>	100cm Drawerline Cabinet
<b>SUN-BU6</b>	100cm Sink Cabinet (excluding sinks and taps)
<b>SUN-BU7</b>	'L' Shaped Corner Base Cabinet
<b>SUN-DT1</b>	Drawer Insert (50cm widths - base cabinets only)

**Sun-WU1 30cm Wall Cabinet**

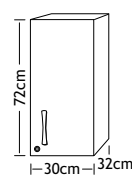

**Sun-WU2 50cm Wall Cabinet**

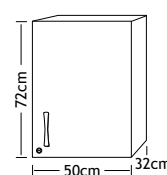

**Sun-WU3 100cm Wall Cabinet**

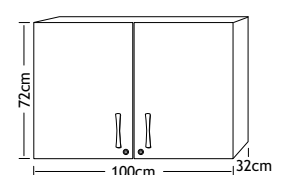

**Sun-WU4 Corner Wall Cabinet**

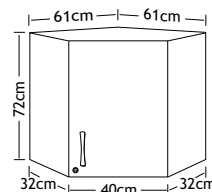

**finishes**  
please specify when ordering



beech

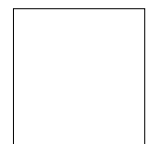

white "high" gloss

Also available in 40cm, 60cm and 80cm widths

### WALL CABINETS

<b>SUN-WU1</b>	30cm Wall Cabinet
<b>SUN-WU2</b>	50cm Wall Cabinet
<b>SUN-WU3</b>	100cm Wall Cabinet
<b>SUN-WU4</b>	Corner Wall Cabinet

## Daniels SHARPSGUARD® Yellow

SHARPSGUARD® Yellow is a comprehensive range of containers for the safe disposal of sharps, including those contaminated with medicinal products and their residues.

The container labels indicate that disposal should be by incineration or other authorised process and is designed for the consignment of waste. Manufactured to BS EN ISO 23907.

- Temporary closure feature
- Visible 'fill' line
- Manufactured to ISO23907:2019 and ISO 9002 standards
- For sharps container holder please enquire

Wall brackets are also available.

**HCP060.1** 0.6 Litre Container

**HCP062.1** 1 Litre Container

**HCP064.1** 2.5 Litre Container

**HCP066.1** 3.75 Litre Container



**HCP068.1** 5 Litre Container

**HCP070.1** 7 Litre Container

**HCP072.1** 11.5 Litre Container

**HCP074** 22 Litre Container

## Single Apron Dispenser

- Manufactured from mild steel
- Single apron dispenser
- Wall mountable
- Powder coated white

Dimensions: 410 x 162 x 164mm

Shuttleworth



Made in the UK Since 1953

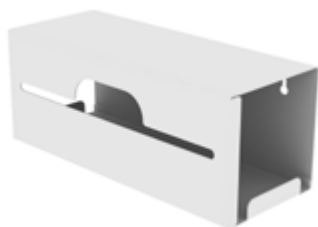

**HCP1590** Wall Mounting Apron Dispenser

## Horizontal Glove and Apron Dispenser

- Manufactured from mild steel
- Three glove box / Single apron capacity
- Horizontal glove box
- Wall mountable
- Powder coated white

Dimensions: 413 x 162 x 425mm

Shuttleworth



Made in the UK Since 1953



**HCP1591** Wall Mounting Horizontal Triple Glove and Apron Dispenser

## Triple Glove Dispenser

- Manufactured from mild steel
- Triple glove box dispenser
- Wall mountable
- Powder coated white

Dimensions: 257 x 92 x 435mm

Shuttleworth



Made in the UK Since 1953



**HCP1593** Wall Mounting Triple Glove Dispenser

## Vertical Glove and Apron Dispenser

- Manufactured from mild steel
- Three glove box / Single apron capacity
- Wall mountable
- Powder coated white

Dimensions: 420 x 144 x 600mm

Shuttleworth



Made in the UK Since 1953



**HCP1592** Wall Mounting Vertical Triple Glove and Apron Dispenser

## Triple Glove Box Holder

- Manufactured from mild steel
- Triple glove box dispenser
- Wall mountable
- Powder coated white

**Dimensions:** 271 x 95 x 383mm

**Shuttleworth**



Made in the  
UK Since 1953



**HCP1594** Wall Mounting Triple Glove Box Holder

## Danicentre

- Lower section will take rolls of aprons, elongated dispensing slot and Large oval apertures for easy access
- Three compartments for different sizes of gloves, overshoes, masks etc.
- Wall mounted dispenser
- **Dimensions:**  
560 x 480mm



**HCP628** Danicentre

**HCP628.1** Danicentre with Soap Dispenser

## Clipboard Chart Holder

**Med 19183**

Designed for the secure storage of A4 sized documents in clipboard style holder.

- Mountable at bedside with integrated hanger

**Shuttleworth**



Made in the  
UK Since 1953



**HCF1456.1** Clipboard Chart Holder, Bedside Mounting (Med 19183)

## Sidhil Plastic Chart Holder

A4 Plastic Chartboard Holder

- Manufactured from PVC
- Supplied with a single strong bull dog clip
- Holds A4 portrait documents
- Available in blue or red



**HCF1306** A4 Plastic Chartboard Holder - Blue

**HCF1307** A4 Plastic Chartboard Holder - Red

## Chart Holders

Designed for the secure storage of A4 sized documents

- Manufactured from mild steel
- Hook for bed end mounting or holes for wall mounting
- Suitable for A4 Charts
- Powder coated white
- Dimensions: 262 x 62 x 315mm

**Shuttleworth**



Made in the  
UK Since 1953

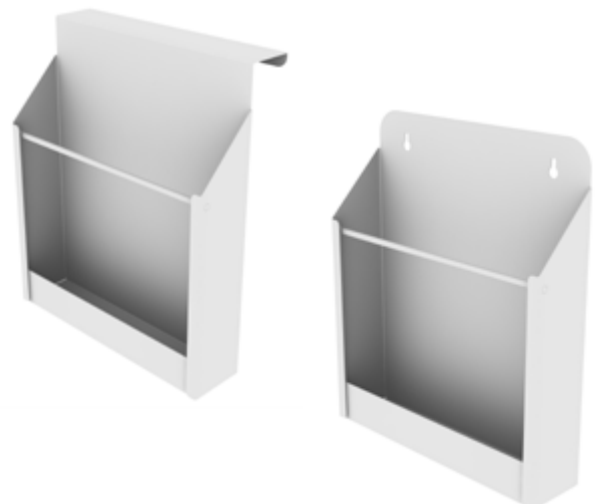

**HCF1456** A4 Chart Holder Steel, Wall Mountable

**HCF1455** A4 Chart Holder Steel, Bedside Mounting



## Controlled Drug Cabinets

Storage cabinets designed for the secure storage of controlled drugs and substances.

Single point locking and fully compliant with BS2881:1989. Each meets legal requirements for the storage of a controlled drug in the United Kingdom: 'The mis-use of drugs (Safe Custody) Regulations 1973'.

- Manufactured from mild steel
- BS3621 Compliant lock with 2 keys included as standard
- Durable drug storage solutions
- Powder coated in white epoxy for ease of cleaning

### Shuttleworth



Made in the UK Since 1953

<b>HCF1404</b>	1000 x 300 x 600mm with Two Euro Locks
<b>HCF1405</b>	1000 x 300 x 900mm with One Euro Lock
<b>HCF1406</b>	1000 x 460 x 1800mm with Four Euro Locks
<b>HCF1408</b>	500 x 300 x 600mm with One Euro Lock
<b>HCF1409</b>	500 x 300 x 900mm with One Euro Lock
<b>HCF1410</b>	600 x 300 x 600mm with One Euro Lock
<b>HCF1411</b>	600 x 300 x 900mm with One Euro Lock
<b>HCF1412</b>	800 x 300 x 600mm with Two Euro Locks
<b>HCF1413</b>	800 x 300 x 900mm with Two Euro Locks



## General Drug Storage Cabinets

General drug storage, ideal for use in medical/ pharmaceutical environments.

Provides a safe location for drug storage in medical settings. Designed to be both secure and easy to access. Each of these cabinets complies with BS2881:1989 (Level One)

- Manufactured from mild steel
- BS3621 Compliant lock with 2 keys included as standard
- Durable drug storage solutions
- Powder coated in white epoxy for ease of cleaning

### Shuttleworth



Made in the UK Since 1953

<b>HCF1414</b>	1000 x 300 x 600mm with Two Euro Locks
<b>HCF1415</b>	1000 x 300 x 900mm with One Euro Lock
<b>HCF1416</b>	1000 x 460 x 1800mm with Four Euro Locks
<b>HCF1417</b>	500 x 300 x 600mm with One Euro Lock
<b>HCF1418</b>	500 x 300 x 900mm with One Euro Lock
<b>HCF1419</b>	600 x 300 x 600mm with One Euro Lock
<b>HCF1420</b>	600 x 300 x 900mm with One Euro Lock
<b>HCF1421</b>	800 x 300 x 600mm with Two Euro Locks
<b>HCF1422</b>	800 x 300 x 900mm with Two Euro Locks





**HCF1457** 5L, One Shelf – 457 x 305 x 457mm

**HCF1466** 5L, One Shelf – 355 x 305 x 710mm

**HCF1467** 10L, One Shelf – 457 x 305 x 710mm

**HCF1468** 10L, One Shelf – 457 x 457 x 610mm

**HCF1469** 10L, One Shelf – 457 x 457 x 760mm

**HCF1471** 15L, One Shelf – 915 x 381 x 610mm

**HCF1464** 15L Wall Mounting, One Shelf – 915 x 381 x 610mm

**HCF1470** 18L, One Shelf – 457 x 457 x 910mm

## Hazardous Substance Cabinet

Ideal for the secure storage of hazardous substances in accordance with Control of Substances Hazardous to Health (COSHH) Regulations 2002.

These cabinets keep potentially dangerous materials safely contained. Their bright yellow exterior indicates danger and provides a warning to those in the vicinity.

Suitably sized fully-welded sump to contain any spilled liquids.

- BS3621 Compliant lock with 2 keys included as standard
- Comprehensive range of sizes/configurations
- Other sizes are available, contact us for more information
- Single/double door depending on size
- Liquid retaining fully welded sump
- GHS labeling included
- Adjustable internal shelving included
- Wall mounting cabinets also available
- Powder coated hi-visibility yellow

**Shuttleworth**



Made in the  
UK Since 1953

**HCF1459** 20L, Three Shelves – 610 x 457 x 1830mm

**HCF1465** 20L Wall Mounting, One Shelf – 915 x 457 x 480mm

**HCF1458** 30L, One Shelf – 915 x 457 x 1000mm

**HCF1472** 30L, One Shelf – 915 x 457 x 610mm

**HCF1473** 30L, One Shelf – 915 x 457 x 710mm

**HCF1460** 36L, Two Shelves – 915 x 457 x 1220mm

**HCF1461** 36L, Two Shelves – 915 x 457 x 1525mm

**HCF1462** 36L, Three Shelves – 915 x 457 x 1830mm

**HCF1463** 45L, Three Shelves – 1220 x 457 x 1830mm

## Inner Controlled Drug Cabinets

Drug storage cabinets with inner storage compartments which are fully compliant with BS2881:1989 and meets legal requirements for the storage of a controlled drug in the United Kingdom: 'The mis-use of drugs (Safe Custody) Regulations 1973'.

- Fully welded cabinet constructed from mild steel
- BS3621 Compliant lock which includes two keys as standard
- Powder coated white epoxy for ease of cleaning

**Shuttleworth**



Made in the  
UK Since 1953



**HCF1431** 300 x 240 x 350mm with Euro Lock

**HCF1432** 300 x 240 x 450mm with Euro Lock

## Ambulance Controlled Drug Cabinets

Fully compliant with BS2881:1989 and meets legal requirements for the storage of a controlled drug in the United Kingdom: 'The mis-use of drugs (Safe Custody) Regulations 1973'.

- Designed for drug storage in ambulances
- Fully welded cabinet constructed from mild steel
- BS3621 Compliant lock which includes two keys as standard
- Powder coated white epoxy for ease of cleaning

**Shuttleworth**



Made in the  
UK Since 1953



**HCF1401** 300 x 180 x 170mm with Mounting Plate

**HCF1402** 300 x 160 x 170mm with Mounting Plate

## Clinical Reagent Cabinet

Secure, locking storage cabinet designed for the safe storage of clinical reagents. Brightly labelled 'CLINICAL REAGENT'.

- Removable interior shelf
- Manufactured from mild steel
- Powder coated in white epoxy for ease of cleaning
- BS3621 Compliant lock with 2 keys included as standard
- Wall mountable

**Dimensions:** 600 x 300 x 600mm

**Shuttleworth**



Made in the UK Since 1953



**HCF1403** Clinical Reagent Cabinet with Cam Lock

## Key Cabinets

Our locking key cabinets are both strong and durable. Designed to secure and store keys, only accessible by trusted key holders.

- Manufactured from mild steel
- Other sizes available, contact us for information
- Powder coated white epoxy for easy of cleaning
- External door lock with two keys included
- Left hand hinge

**Dimensions:** 447 x 287 x 55mm

**Shuttleworth**



Made in the UK Since 1953



**HCF1454** Wall Mounting 15 Key Cabinet with Combi Lock

**HCF1454.1** Wall Mounting 30 Key Cabinet with Combi Lock

## Wall Mounted Patient Drug Cabinet

These metal lockers are designed to store medicines at a patients or residents bedside in a care or hospital environment.

These cabinets are secure, safe and easily accessible for self administration.

- Manufactured from mild steel
- Powder coated in white epoxy for ease of cleaning
- Internal shelving configuration
- Option to wall mount
- BS3621 Compliant lock with 2 keys included as standard
- Available in a range of other sizes with side or bottom hinge

**Shuttleworth**



Made in the UK Since 1953



**HCF1423** 430 x 155 x 260mm with Cam Lock

**HCF1424** 430 x 155 x 260mm with Digital Lock

**HCF1425** 360 x 155 x 428mm with Cam Lock

**HCF1426** 360 x 155 x 428mm with Digital Lock

**HCF1427** 310 x 105 x 260mm with Cam Lock

**HCF1428** 310 x 105 x 260mm with Digital Lock

**HCF1429** 360 x 155 x 260mm with Cam Lock

**HCF1430** 360 x 155 x 260mm with Digital Lock

## Sunflower Controlled Drug Cabinets

Our range of high quality controlled drug cabinets conform to and exceed both the Misuse of Drugs (Safe Custody) Regulations 1973 and are independently tested to the British Standard (BS 2881:1989 Security Level 1), making them suitable for use in health centres, hospitals, nursing homes, vets, prisons and other healthcare buildings.

- Independently tested
- Meets the Misuse of Drugs (Safe Custody Regulation 1973)
- BS 2881:1989 Security Level 1 compliant
- High security 8 lever lock designed to EN1300 and Vds 2396
- Anti-pick levers & deadlock mechanism
- 3 keys supplied (per lock) Extra keys available
- Protective key escutcheon
- Adjustable shelves and door trays
- Internal door retaining flange
- Durable and hygienic white epoxy coating
- Single door cabinets are right hand hinged (left hand optional)
- Optional warning light and buzzer alarm
- Easy clean design and materials
- Supplied fully assembled
- **NEW** 5 year warranty



SUN-CDC21



SUN-CDC24



SUN-CDC27

<b>SUN-CDC21-NL</b>	CDC with 1 Shelf and 1 Door
<b>SUN-CDC22-NL</b>	CDC with 1 Shelf, 1 Door Tray and 1 Door
<b>SUN-CDC23-NL</b>	CDC with 2 Shelves, 2 Door Trays and 1 Door
<b>SUN-CDC24-NL</b>	CDC with 2 Shelves, 2 Door Trays and 1 Door
<b>SUN-CDC25-NL</b>	CDC with 2 Shelves, 2 Door Trays and 1 Door
<b>SUN-CDC27-NL</b>	CDC with 8 Shelves, 8 Door Trays, 2 Door and 2 Locks
<b>SUN-CDC-LIGHT1*</b>	Warning Light - see below (adds 55mm to overall height)
<b>SUN-CDC-LIGHT2*</b>	Warning Light - see below (adds 55mm to overall height)
<b>SUN-CDC-LIGHT3*</b>	Warning Light - see below (adds 55mm to overall height)
<b>SUN-CDC-BUZZ*</b>	Warning Buzzer (can only be ordered with warning light)
<b>SUN-CDC-LHH*</b>	Left Hand Hinge Option
<b>SUN-CDC-KEY*</b>	Spare Key for CDC Cabinet (when ordered with cabinet)
<b>SUN-CDC-KEY1</b>	Replacement Key for CDC Cabinet (when ordered later)

\*These accessories can only be fitted when ordered with the cabinet

5V DC external warning light shows green when closed, red when open and flashes red when left open for 2.5 minutes. Nurse call output, (voltage free contact) for connection to nurse call system. Internal illumination when door is opened. Must be hard wired to a 220/240V AC mains supply. Buzzer alarm activates when cabinet is left open for 5 minutes (only available when combined with optional warning light)



**SUN-CDC-LIGHT1\***  
(For Sun-CDC21-CDC22-CDC23 Cabinets)  
**SUN-CDC-LIGHT2\***  
(For Sun-CDC24-CDC25 Cabinets)  
**SUN-CDC-LIGHT3\***  
(For Sun-CDC27 Cabinet)



**SUN-CDC-BUZZ**  
Buzzer Alarm  
(has to be combined with Sun-CDC-Light)



**SUN-CDC-LHH**  
Left Hand Hinge Option



**SUN-CDC-KEY**  
Additional Key  
(when ordered with cabinet)



CDC21	CDC22	CDC23	CDC24	CDC25
30cm(H)	30cm(H)	55cm(H)	55cm(H)	60cm(H)
21cm(W)	34cm(W)	34cm(W)	50cm(W)	60cm(W)
27cm(D)	27cm(D)	27cm(D)	30cm(D)	30cm(D)

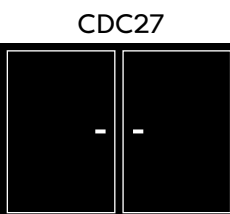

**CDC27**  
85cm(H)  
100cm(W)  
30cm(D)



# Sunflower Medicine Cabinets with Controlled Drug Inner Cabinet

Our range of medicine/pharmacy cabinets have being combined with a range of controlled drug inner cabinets where extra security situations are required. They are ideally suited to higher security areas in health centres, hospitals, dispensaries, nursing homes, prisons, vets and other healthcare buildings.

- Independently tested by FIRA
- Meets the Misuse of Drugs (Safe Custody Regulation 1973)
- BS 2881:1989 Security Level 1 compliant
- High security 8 lever lock designed to EN1300 and Vds 2396
- Anti-pick levers & deadlock mechanism
- 3 keys supplied (per lock) Extra keys available
- Protective key escutcheon on outer cabinet
- 5V External warning light is green when closed, red when open - fitted as standard on outer medicine cabinet
- Optional warning light and buzzer alarm
- Adjustable shelves and door trays
- Identification coloured key fobs
- Identification key escutcheon on inner cabinet
- Internal door retaining flange
- Durable and hygienic white epoxy coating
- Single door cabinets are right hand hinged (left hand optional)
- Easy clean design and materials
- Supplied fully assembled
- **NEW** 5 year warranty



SUN-MCDC321



SUN-MCDC722



SUN-MCDC922

<b>SUN-MCDC221</b>	MC2 Outer Cabinet with CDC21 Inner Cabinet
<b>SUN-MCDC321</b>	MC3 Outer Cabinet with CDC21 Inner Cabinet
<b>SUN-MCDC322</b>	MC3 Outer Cabinet with CDC22 Inner Cabinet
<b>SUN-MCDC522</b>	MC5 Outer Cabinet with CDC22 Inner Cabinet
<b>SUN-MCDC722</b>	MC7 Outer Cabinet with CDC22 Inner Cabinet
<b>SUN-MCDC723</b>	MC7 Outer Cabinet with CDC23 Inner Cabinet
<b>SUN-MCDC921</b>	MC9 Outer Cabinet with CDC21 Inner Cabinet
<b>SUN-MCDC922</b>	MC9 Outer Cabinet with CDC22 Inner Cabinets
<b>SUN-MCDC923</b>	MC9 Outer Cabinet with CDC23 Inner Cabinet
<b>SUN-MC-BUZZ*</b>	Warning Buzzer (can only be ordered with warning light)
<b>SUN-MC-LHH*</b>	Left Hand Hinge Option
<b>SUN-MC-KEY*</b>	Spare Key for MC Cabinet (when ordered with cabinet)
<b>SUN-MC-KEY1</b>	Replacement Key for MC Cabinet (when ordered later)
<b>SUN-CDC-KEY*</b>	Spare Key for CDC Inner Cabinet (when ordered with cabinet)
<b>SUN-CDC-KEY1</b>	Replacement Key for CDC Inner Cabinet (when ordered later)

\*These accessories can only be fitted when ordered with the cabinet

5V DC external warning light shows green when closed, red when open and flashes red when left open for 2.5 minutes. Nurse call output, (volt free contact) for connection to nurse call system. Internal illumination when door is opened. Must be hard wired to a 220/240V AC mains supply. Buzzer alarm activates when cabinet is left open for 5 minutes (only available when combined with optional warning light)



**SUN-MC-BUZZ**  
Buzzer Alarm  
(has to be combined with Sun-MC-Light)



**SUN-MC-LHH**  
Left Hand Hinge Option



**SUN-MC-KEY**  
Additional Key  
(when ordered with cabinet)



CDC21	CDC22	CDC23
30cm(H)	30cm(H)	55cm(H)
21cm(W)	34cm(W)	34cm(W)
27cm(D)	27cm(D)	27cm(D)

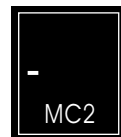

**MC2**  
60cm(H)  
50cm(W)  
30cm(D)

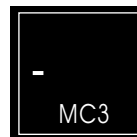

**MC3**  
60cm(H)  
60cm(W)  
30cm(D)



**MC7**  
85cm(H)  
60cm(W)  
30cm(D)

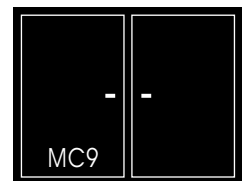

**MC9**  
85cm(H)  
100cm(W)  
30cm(D)

# Sunflower Medicine Cabinets

Sunflower medicine/pharmacy cabinets are independently tested to the British Standard (BS 2881:1989 Security Level 1), making them suitable for use in health centres, hospitals, nursing homes, vets, prisons and other health care buildings.

- Independently tested by FIRA
- BS 2881:1989 Security Level 1 compliant
- High security 8 lever lock designed to EN1300 and Vds 2396
- Anti-pick levers & deadlock mechanism
- 3 keys supplied (per lock) Extra keys available
- Protective key escutcheon
- Adjustable shelves and door trays
- Internal door retaining flange
- Durable and hygienic white epoxy coating
- Single door cabinets are right hand hinged (left hand optional)
- Optional warning light and buzzer alarm
- Easy clean design and materials
- Supplied fully assembled
- **NEW** 5 year warranty



SUN-MC6



SUN-MC8

<b>SUN-MC1-NL</b>	MC with 3 Shelves, 2 Door Trays and 1 Door
<b>SUN-MC2-NL</b>	MC with 3 Shelves, 2 Door Trays and 1 Door
<b>SUN-MC3-NL</b>	MC with 3 Shelves, 2 Door Trays and 1 Door
<b>SUN-MC4-NL</b>	MC with 6 Shelves, 4 Door Trays and 2 Doors
<b>SUN-MC5-NL</b>	MC with 6 Shelves, 4 Door Trays and 2 Doors
<b>SUN-MC7-NL</b>	MC with 4 Shelves, 4 Door Trays and 1 Door
<b>SUN-MC8-NL</b>	MC with 8 Shelves, 8 Door Trays and 2 Doors
<b>SUN-MC9-NL</b>	MC with 8 Shelves, 8 Door Trays and 2 Doors
<b>SUN-MC-LIGHT1*</b>	Warning Light - see below (adds 55mm to overall height)
<b>SUN-MC-LIGHT2*</b>	Warning Light - see below (adds 55mm to overall height)
<b>SUN-MC-LIGHT3*</b>	Warning Light - see below (adds 55mm to overall height)
<b>SUN-MC-BUZZ*</b>	Warning Buzzer (can only be ordered with warning light)
<b>SUN-MC-LHH*</b>	Left Hand Hinge Option
<b>SUN-MC-KEY*</b>	Spare Key for MC Cabinet (when ordered with cabinet)
<b>SUN-MC-KEY1</b>	Replacement Key for MC Cabinet (when ordered later)

\*These accessories can only be fitted when ordered with the cabinet

5V DC external warning light shows green when closed, red when open and flashes red when left open for 2.5 minutes. Nurse call output, (volt free contact) for connection to nurse call system. Internal illumination when door is opened. Must be hard wired to a 220/240V AC mains supply. Buzzer alarm activates when cabinet is left open for 5 minutes (only available when combined with optional warning light)



**SUN-MC-LIGHT1\***

(For Sun-MC1-MC2-MC3 Cabinets)

**SUN-MC-LIGHT2\***

(For Sun-MC7 Cabinets)

**SUN-MC-LIGHT3\***

(For Sun-MC4-MC5-MC8-MC9 Cabinet)



**SUN-MC-BUZZ**

Buzzer Alarm  
(has to be combined with Sun-MC-Light)



**SUN-MC-LHH**

Left Hand Hinge Option



**SUN-MC-KEY**

Additional Key  
(when ordered with cabinet)



60cm(H) 30cm(W) 30cm(D)	60cm(H) 50cm(W) 30cm(D)	60cm(H) 60cm(W) 30cm(D)
-------------------------------	-------------------------------	-------------------------------

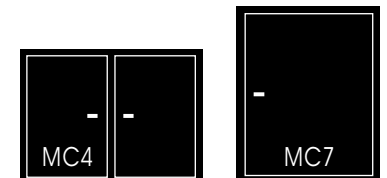

60cm(H) 80cm(W) 30cm(D)	85cm(H) 60cm(W) 30cm(D)
-------------------------------	-------------------------------

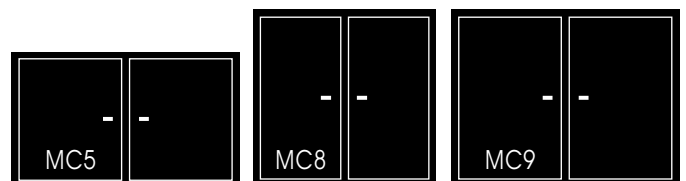

60cm(H) 100cm(W) 30cm(D)	85cm(H) 80cm(W) 30cm(D)	85cm(H) 100cm(W) 30cm(D)
--------------------------------	-------------------------------	--------------------------------

## Case Note Trolleys

Our Case Note Trolleys are lightweight whilst still being functional, strong, secure and easy to clean. Each trolley comes fully assembled with secure locking top and the option of a digital locking system.

- Mild steel frame/Aluminium lids
- Secured with either CAM lock or Lowe and Fletcher 3780 Digital Lock
- Powder coated white/blue
- Lower storage shelf
- Side handles for manoeuvrability
- A4 Chart holder
- Mounted on 4x 100mm swivel Tente ® Castors
- Two brake castors included

**Dimensions:** 800 x 467 x 947.5mm

Shuttleworth



Made in the  
UK Since 1953



**HCF1442** Case Note Trolley with Cam Lock

**HCF1443** Case Note Trolley with Digital Lock

## Large Case Note Trolleys

Our Case Note Trolleys are lightweight whilst still being functional, strong, secure and easy to clean. Each trolley comes fully assembled with secure locking top and the option of a digital locking system.

- Larger internal space
- Mild steel frame/Aluminium lids
- Secured with either CAM lock or Lowe and Fletcher 3780 Digital Lock
- Powder coated white/blue
- Side handles for manoeuvrability
- Lower storage shelf
- Mounted on 4x 100mm swivel Tente ® Castors
- Two brake castors included

**Dimensions:** 1035 x 467 x 947.5mm

Shuttleworth



Made in the  
UK Since 1953



**HCF1445** Large Case Note Trolley with Cam Lock

**HCF1446** Large Case Note Trolley with Digital Lock

Shuttleworth



Made in the  
UK Since 1953



## Eight Shelf Case Note Trolley

- Manufactured from mild steel
- Secured with CAM lock
- Powder coated blue
- Eight removable shelves
- Lower storage section
- Mounted on 4x 100mm swivel Tente ® Castors
- Protective rubber buffers
- White MDF top

**Overall Dimensions:** 610 x 461 x 1132.5mm

**HCF1444** Eight Shelf, Lockable Case Note Trolley

## Sunflower Medical Notes Trolleys

Designed to provide a complete solution for storing, distributing and accessing medical notes and X-Rays. Medical notes trolleys are aesthetically pleasing, hygienically designed and combine smart adjustable filing pockets with easy access, while being functional, strong, secure and easy to clean.

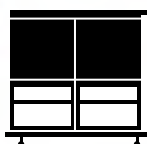

106cm(H) 121cm(W) 52cm(D)  
121cm(W) 57cm(D) with buffers

SUN-MNT20



106cm(H) 64cm(W) 52cm(D)  
66cm(W) 57cm(D) with buffers

SUN-MNT10

- Lightweight easy to manoeuvre design
- Secure locking top (2 keys per lock) keyed to differ\* as required by NHS England
- Secure solid sides and base
- Accepts foolscap or X-Ray size filing pockets (not included)
- Accepts 470mm & 360mm filing pockets (not included)
- Filing pocket identification label for easy re-ordering
- Wipe clean filing pocket tabs (supplied with pockets)
- Hinged tops open to create additional working space
- Hygienic stainless steel handles
- Removable storage trays
- Side storage for patients record file
- Push pull handles
- Four 100mm braked castors
- Four protective buffers
- Durable laminate faced MDF with 2mm edging
- Easy clean design and materials
- Supplied fully assembled
- **NEW** 5 year warranty

\* Keyed to differ as specified by NHS England  
(keyed to differ means each trolley has its own unique set of keys)

\* these accessories can only be fitted when ordered with trolley



Sun-LC3A\*  
Antistatic Braked  
Castors

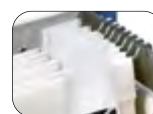

Sun-MNT-FPF-PK10  
Filing Pocket Foolscap  
360mm(W) x  
270mm(D)  
(Pack of 10)

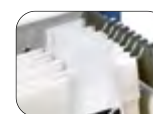

Sun-MNT-WFPF-PK10  
Wide Filing  
Pocket Foolscap  
450mm(W) x 270mm(D)  
(Pack of 10)



Sun-MNT-FPX-PK10  
Filing Pocket X-Ray  
360mm(W) x  
470mm(D)  
(Pack of 10)



Sun-MNT-WFPX-PK10  
Wide Filing  
Pocket X-Ray  
450mm(W) x  
470mm(D)  
(Pack of 10)



Sun-MNT-FPXF-PK10  
Twin Filing Pocket  
X-Ray & Foolscap  
360mm(W) x  
270/470mm(D)  
(Pack of 10)



Sun-MNT-WFPXF-PK10  
Twin Wide Filing Pocket  
X-Ray & Foolscap  
450mm(W) x  
270/470mm(D)  
(Pack of 10)

**SUN-MNT10** Medium Medical Notes Trolley - Enclosed sides hinged top

**SUN-MNT20** Large Medical Notes Trolley - Enclosed sides hinged tops

**SUN-LC3A\*** Antistatic Braked Castors

**SUN-MNT-FPF-PK10** Filing Pocket Foolscap (10pk) 360mm(W) x 270mm(D)

**SUN-MNT-WFPF-PK10** Wide Filing Pocket Foolscap (10pk) 450mm(W) x 270mm(D)

**SUN-MNT-FPX-PK10** Filing Pocket X-Ray (10pk) 360mm(W) x 470mm(D)

**SUN-MNT-WFPX-PK10** Wide Filing Pocket X-Ray (10pk) 450mm(W) x 470mm(D)

**SUN-MNT-FPXF-PK10** Twin Filing Pocket X-Ray & Foolscap (10pk)  
360mm(W) x 270-470mm(D)

**SUN-MNT-WFPXF-PK10** Twin Wide Filing Pocket X-Ray & Foolscap (10pk)  
450mm(W) x 270-470mm(D)

\*These accessories can only be fitted when ordered with the trolley

### Sun-MNT10

Trolley can accept all filing pocket sizes but cannot be combined together.

### Sun-MNT20

Trolley can accept all filing pocket sizes which can be used together but only in opposite sides of the trolley.



# Sunflower Medical Notes Trolleys

Designed to provide a complete solution for storing, distributing and accessing medical notes and X-Rays. Medical notes trolleys are aesthetically pleasing, hygienically designed and combine smart adjustable filing pockets with easy access, while being functional, strong, secure and easy to clean.

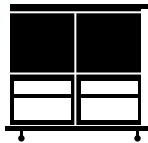

106cm(H) 121cm(W) 52cm(D)  
121cm(W) 57cm(D) with buffers

SUN-MNT20-DCL

- Lightweight easy to manoeuvre design
- 2 Digital combination locks with optional overriding key (override key(s) must be ordered with trolley)
- Secure solid sides and base
- Accepts fooscap or X-Ray size filing pockets (not included)
- Accepts 470mm & 360mm filing pockets (not included)
- Filing pocket identification label for easy re-ordering
- Wipe clean filing pocket tabs (supplied with pockets)
- Hinged tops open to create additional working space
- Hygienic stainless steel handles
- Removable storage trays
- Side storage for patients record file
- Push pull handles
- Four 100mm braked castors
- Four protective buffers
- Durable laminate faced MDF with 2mm edging
- Easy clean design and materials
- Supplied fully assembled
- **NEW 5 year warranty**

Digital locking system with optional overriding key (override key(s) must be ordered with trolley)



106cm(H) 64cm(W) 52cm(D)  
66cm(W) 57cm(D) with buffers

SUN-MNT10-DCL

\* these accessories can only be fitted when ordered with trolley



**Sun-LC3A\***  
Antistatic Braked Castors

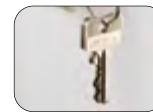

**Sun-MNT-DCL-KEY\***  
Overriding Key for Digital Locking System



**Sun-MNT-FPF-PK10**  
Filing Pocket Fooscap  
360mm(W) x 270mm(D)  
(Pack of 10)

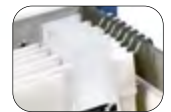

**Sun-MNT-WFPF-PK10**  
Wide Filing Pocket Fooscap  
450mm(W) x 270mm(D)  
(Pack of 10)



**Sun-MNT-FPX-PK10**  
Filing Pocket X-Ray  
360mm(W) x 470mm(D)  
(Pack of 10)



**Sun-MNT-WFPX-PK10**  
Wide Filing Pocket X-Ray  
450mm(W) x 470mm(D)  
(Pack of 10)



**Sun-MNT-FPXF-PK10**  
Twin Filing Pocket X-Ray & Fooscap  
360mm(W) x 270/470mm(D)  
(Pack of 10)



**Sun-MNT-WFPXF-PK10**  
Twin Wide Filing Pocket X-Ray & Fooscap  
450mm(W) x 270/470mm(D)  
(Pack of 10)

**SUN-MNT10-DCL** Medium Medical Notes Trolley with 1 Digital Combination Lock  
Enclosed sides hinged top

**SUN-MNT20-DCL** Large Medical Notes Trolley with 2 Digital Combination Locks  
Enclosed sides hinged tops

**SUN-LC3A\*** Antistatic Braked Castors

**SUN-DCL-KEY\*** Override Key for Digital Locking System

**SUN-MNT-FPF-PK10** Filing Pocket Fooscap (10pk) 360mm(W) x 270mm(D)

**SUN-MNT-WFPF-PK10** Wide Filing Pocket Fooscap (10pk) 450mm(W) x 270mm(D)

**SUN-MNT-FPX-PK10** Filing Pocket X-Ray (10pk) 360mm(W) x 470mm(D)

**SUN-MNT-WFPX-PK10** Wide Filing Pocket X-Ray (10pk) 450mm(W) x 470mm(D)

**SUN-MNT-FPXF-PK10** Twin Filing Pocket X-Ray & Fooscap (10pk)  
360mm(W) x 270-470mm(D)

**SUN-MNT-WFPXF-PK10** Twin Wide Filing Pocket X-Ray & Fooscap (10pk)  
450mm(W) x 270-470mm(D)

\*These accessories can only be fitted when ordered with the trolley

**Sun-MNT10/DCL**

Trolley can accept all filing pocket sizes but cannot be combined together.

**Sun-MNT20/DCL**

Trolley can accept all filing pocket sizes which can be used together but only in opposite sides of the trolley.

## Chart Board Trolleys

Fixed height, portable chart board trolleys combining the portable storage with fictional writing options.

Includes a single lockable drawer with optional lower storage shelf and choice of stainless steel worktop or hinged writing board.

Also available as a medi-storage trolley with tilting writing top. Allowing for more comprehensive storage below the writing top.

- Includes dual handle, single lockable storage drawer as standard
- Select from your preferred choice of hinged writing board or stainless steel worktop as required
- Hinged writing board includes paper holder clips to secure documents/paper
- Durable design manufactured from mild steel
- Powder coated in white epoxy for ease of cleaning
- Trolleys are easy to manoeuvre being mounted on 4x 100mm swivel castors

**HCF1545** Chart Board Trolley with Hinged Writing Board

**HCF1546** Chart Board Trolley with Stainless Steel Top

**HCF1547** Column Medical Trolley with Hinged Writing Board

Shuttleworth



Made in the UK Since 1953

HCF1547



HCF1545

## Medical Records Trolleys

Catering for a varied range of needs & purposes across working environments. These multi-functional trolleys are an essential part of any medical setting.

Available in two or three shelf combinations with raised edges to avoid any movement and falls outside of the tray.

Manufactured in your choice mild or stainless steel, each allows for ease of cleaning and decontamination procedures to be completed.

- 40mm raised edges on each shelf to secure contents
- Trolleys are easy to maneuver as mounted on 4x 100mm swivel castors
- Protective buffers included on each corner to protect doorways and walls
- Push handles at either end for ease of handling
- Ideal for storing a range of medical records including x-rays and patient documents

**HCF1447** Records Trolley with Top Basket

**HCF1448** Records Trolley with Two Shelves & Eight Dividers

**HCF1538** Records Trolley with Locked Top Box

**HCF1539** Records Trolley with Large Locked Top Box

**HCF1540** Records Trolley with Locked Upper & Lower Boxes

**HCF1541** Records Trolley with Large Locked Upper & Lower Boxes

Shuttleworth



Made in the UK Since 1953



HCF1438



HCF1448

## Sunflower Records Transfer Trolleys

Designed to provide a complete solution for storing, distributing and transferring medical notes and files quickly to different locations. Records transfer trolleys are aesthetically pleasing, hygienically designed and easy to access, while being functional, strong, secure and easy to clean.



- Lightweight easy to manoeuvre design
- Secure locking top (Sun-MRTTL1 only)
- Lock supplied with 2 keys - keyed to differ\*
- Locking top folds neatly back
- Hygienic stainless steel handle
- Maximum Load 60kg
- Strong deep cabinet for optimum storage
- Easy access to files and documents
- 2 removable storage trays
- Secure solid sides and base
- Push pull handles
- Durable powder coated blue frame
- 100mm castors (2 braked)
- Four protective buffers
- Durable laminate faced MDF with 2mm edging
- Easy clean design and materials
- Supplied fully assembled
- **NEW** 5 year warranty

\* Keyed to differ as specified by NHS England (keyed to differ means each trolley has its own unique set of keys)



SUN-MRTTL1



SUN-MRTT1



<b>SUN-MRTT1</b>	Records Transfer Trolley - Open
<b>SUN-MRTT1</b>	Records Transfer Trolley - With Folding Locking Top
<b>SUN-LC3A*</b>	Antistatic Braked Castors
<b>SUN-MRTT-KEY*</b>	Additional Key

\*These accessories can only be fitted when ordered with the trolley



**Sun-LC3A\***  
Antistatic Braked Castors

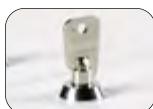

**Sun-MRTT-KEY\***  
Additional Key

\* these accessories can only be fitted when ordered with trolley

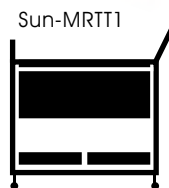

Sun-MRTT1  
98cm(H) 81cm(W) 52cm(D)  
83cm(W) 57cm(D) with buffers

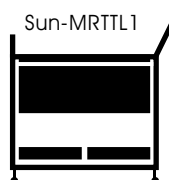

Sun-MRTTL1  
98cm(H) 81cm(W) 52cm(D)  
83cm(W) 57cm(D) with buffers



## A4 Medical Storage Trolleys

Versatile medical storage trolleys offering well-designed simple storage solutions. Offered in a comprehensive range of sizes to meet your requirements. **Trays are supplied as standard with your trolley** and all trays are fully interchangeable within the range.

The trolleys are constructed using mild steel frames and are epoxy powder coated for a strong durable finish. The trolleys include a removable drop-in top for ease of cleaning.

- Strong, robust and efficient design
- Supplied fully assembled
- Epoxy powder coated for easy cleaning and a lasting finish
- Trays are interchangeable allowing a wide variety of combinations
- High quality 'Tente' castors including two front brakes
- Grey rubber buffer wheels for protection against obstacles
- Dimensions are subject to slight changes due to an upcoming range redesign
- Manufactured in the UK and CE Marked

### Warranty

The medical storage trolley range includes a five year manufacturers warranty as standard.



Shuttleworth



Made in the UK Since 1953

<b>HCF1355</b>	Double – 762 x 467 x 947.5mm
<b>HCF1359</b>	Double, Enclosed Sides – 762 x 467 x 947.5mm
<b>HCF1366</b>	Double, Door Locks – 762 x 467 x 947.5mm
<b>HCF1356</b>	Double, Bow Handle – 762 x 467 x 1037.5mm
<b>HCF1357</b>	Double, Bow Handle, Enclosed Sides – 762 x 467 x 1037.5mm
<b>HCF1358</b>	Double, Bow Handle, Door Locks – 762 x 467 x 1037.5mm
<b>HCF1360</b>	Low Double – 762 x 467 x 752.5mm
<b>HCF1364</b>	Low Double, Enclosed Sides – 762 x 467 x 752.5mm
<b>HCF1365</b>	Low Double, Door Locks – 762 x 467 x 752.5mm
<b>HCF1361</b>	Low Double, Bow Handle – 762 x 467 x 847.5mm
<b>HCF1362</b>	Low Double, Bow Handle, Enclosed Sides – 762 x 467 x 847.5mm
<b>HCF1363</b>	Low Double, Bow Handle, Door Locks – 762 x 467 x 847.5mm
<b>HCF1374.5</b>	Tall Double – 762 x 467 x 970mm
<b>HCF1374.6</b>	Tall Double, Enclosed Sides – 762 x 467 x 970mm
<b>HCF1374.7</b>	Tall Double, Bow Handle – 762 x 467 x 1105mm
<b>HCF1374.8</b>	Tall Double, Bow Handle, Enclosed Sides – 762 x 467 x 1105mm

<b>HCF1367</b>	Single – 411 x 467 x 947.5mm
<b>HCF1370</b>	Single, Enclosed Sides – 411 x 467 x 947.5mm
<b>HCF1377</b>	Single, Door Locks – 411 x 467 x 752.5mm
<b>HCF1368</b>	Single, Bow Handle – 411 x 467 x 1037.5mm
<b>HCF1369</b>	Single, Bow Handle, Enclosed Sides – 411 x 467 x 1037.5mm
<b>HCF1369.1</b>	Single, Bow Handle, Door Locks – 411 x 467 x 1037.5mm
<b>HCF1371</b>	Low Single – 411 x 467 x 752.5mm
<b>HCF1375</b>	Low Single, Enclosed Sides – 411 x 467 x 752.5mm
<b>HCF1376</b>	Low Single, Door Locks – 411 x 467 x 752.5mm
<b>HCF1372</b>	Low Single, Bow Handle – 762 x 467 x 847.5mm
<b>HCF1373</b>	Low Single, Bow Handle, Enclosed Sides – 411 x 467 x 847.5mm
<b>HCF1374</b>	Low Single, Bow Handle, Door Locks – 411 x 467 x 847.5mm
<b>HCF1374.1</b>	Tall Single – 411 x 467 x 970mm
<b>HCF1374.2</b>	Tall Single, Enclosed Sides – 411 x 467 x 970mm
<b>HCF1374.3</b>	Tall Single, Bow Handle – 411 x 467 x 1105mm
<b>HCF1374.4</b>	Tall Single, Bow Handle, Enclosed Sides – 411 x 467 x 1105mm

## Storage Trolley Accessories

**Glove box holder designed for easy, drop-in use**

- **Holds:** 126x231x78mm
- **Overall:** 233x130x82mm

**Hand Sanitiser designed for easy drop-in use**

- **Holds:** 231x92x88mm
- **Overall:** 233x96x90mm

**Document/Clipboard Holder Designed for easy drop-in use**

- **Holds:** 366x236x26mm
- **Overall:** 368x240x30mm

**Universal Sharps Bin Holder for use with standard sizes**

- **Holds:** 205mm Diam. Bin
- **Overall:** 230x130x118mm



<b>TRAC02</b>	Glove Box Holder
<b>TRAC03</b>	Gel Holder

<b>TRAC04</b>	Document Holder
<b>TRAC05</b>	Sharps Bin Holder

## A3 Medical Storage Trolleys

Versatile medical storage trolleys offering well-designed simple storage solutions. Offered in a comprehensive range of sizes to meet your requirements. **Trays are supplied as standard with your trolley** and all trays are fully interchangeable within the range.

The trolleys are constructed using mild steel frames and are epoxy powder coated for a strong durable finish. The trolleys include a removable drop-in top for ease of cleaning.

- Strong, robust and efficient design
- Supplied fully assembled
- Epoxy powder coated for easy cleaning and a lasting finish
- Trays are interchangeable allowing a wide variety of combinations
- High quality 'Tente' castors including two front brakes
- Grey rubber buffer wheels for protection against obstacles
- Dimensions are subject to slight changes due to an upcoming range redesign
- Manufactured in the UK and CE Marked

### Warranty

The medical storage trolley range includes a five year manufacturers warranty as standard.



Shuttleworth



Made in the UK Since 1953

B

Furniture

<b>HCF1378</b>	Double – 1070 x 467 x 947.5mm
<b>HCF1381</b>	Double, Enclosed Sides – 1070 x 467 x 947.5mm
<b>HCF1389</b>	Double, Door Locks – 1070 x 467 x 947.5mm
<b>HCF1379</b>	Double, Bow Handle – 1070 x 467 x 1037.5mm
<b>HCF1382</b>	Double, Bow Handle, Enclosed Sides – 1070 x 467 x 1037.5mm
<b>HCF1380</b>	Double, Bow Handle, Door Locks – 1070 x 467 x 1037.5mm
<b>HCF1383</b>	Low Double – 1070 x 467 x 752.5mm
<b>HCF1387</b>	Low Double, Enclosed Sides – 1070 x 467 x 752.5mm
<b>HCF1388</b>	Low Double, Door Locks – 1070 x 467 x 752.5mm
<b>HCF1384</b>	Low Double, Bow Handle – 1070 x 467 x 847.5mm
<b>HCF1385</b>	Low Double, Bow Handle, Enclosed Sides – 1070 x 467 x 847.5mm
<b>HCF1386</b>	Low Double, Bow Handle, Door Locks – 1070 x 467 x 847.5mm
<b>HCF1397.5</b>	Tall Double – 1070 x 467 x 947.5mm
<b>HCF1397.6</b>	Tall Double, Enclosed Sides – 1070 x 467 x 947.5mm
<b>HCF1397.7</b>	Tall Double, Bow Handle – 1070 x 467 x 1037.5mm
<b>HCF1397.8</b>	Tall Double, Bow Handle, Enclosed Sides – 1070 x 467 x 1037.5mm

<b>HCF1390</b>	Single – 565 x 467 x 947.5mm
<b>HCF1330</b>	Single, Enclosed Sides – 565 x 467 x 947.5mm
<b>HCF1399</b>	Single, Door Locks – 565 x 467 x 752.5mm
<b>HCF1391</b>	Single, Bow Handle – 565 x 467 x 1037.5mm
<b>HCF1392</b>	Single, Bow Handle, Enclosed Sides – 565 x 467 x 1037.5mm
<b>HCF1393</b>	Single, Bow Handle, Door Locks – 565 x 467 x 1037.5mm
<b>HCF1394</b>	Low Single – 565 x 467 x 752.5mm
<b>HCF1352</b>	Low Single, Enclosed Sides – 565 x 467 x 752.5mm
<b>HCF1398</b>	Low Single, Door Locks – 565 x 467 x 752.5mm
<b>HCF1395</b>	Low Single, Bow Handle – 762 x 467 x 847.5mm
<b>HCF1396</b>	Low Single, Bow Handle, Enclosed Sides – 565 x 467 x 847.5mm
<b>HCF1397</b>	Low Single, Bow Handle, Door Locks – 565 x 467 x 847.5mm
<b>HCF1397.1</b>	Tall Single – 565 x 467 x 947.5mm
<b>HCF1397.2</b>	Tall Single, Enclosed Sides – 565 x 467 x 947.5mm
<b>HCF1397.3</b>	Tall Single, Bow Handle – 565 x 467 x 1037.5mm
<b>HCF1397.4</b>	Tall Single, Bow Handle, Enclosed Sides – 565 x 467 x 1037.5mm

## Storage Trolley Accessories

**Glove box holder designed for easy, drop-in use**

- **Holds:** 126x231x78mm
- **Overall:** 233x130x82mm

**Hand Sanitiser designed for easy drop-in use**

- **Holds:** 231x92x88mm
- **Overall:** 233x96x90mm

**Document/Clipboard Holder Designed for easy drop-in use**

- **Holds:** 366x236x26mm
- **Overall:** 368x240x30mm

**Universal Sharps Bin Holder for use with standard sizes**

- **Holds:** 205mm Diam. Bin
- **Overall:** 230x130x118mm



<b>TRAC02</b>	Glove Box Holder
<b>TRAC03</b>	Gel Holder

<b>TRAC04</b>	Document Holder
<b>TRAC05</b>	Sharps Bin Holder

## Sunflower VISTA Trolley Range

The Sunflower range of Vista medical trolleys and storage modules is extensive, with options to suit all applications and environments, from GP or hospital consultation and treatment rooms, to hospital wards and intensive care units. The product range is designed to be easy to clean, with smooth lines and minimal dirt traps. Each medical trolley or storage module can be accessorised with medi-rails, sharps box holders, glove box holders, alcohol gel holders, oxygen cylinder holders, laptop holders, and more.

- All Trolleys incorporate our tilt & locking tray runner system
- Trays integrate with all other Vista products
- Locking door option provides tamper resistant security
- Choice of removable single and double depth trays
- Choice of 3 tray colours (Clear, Blue and Green)
- Tray labels and covers included
- 100mm castors with front brakes
- Removable top shelf with integrated upstand
- Easy clean design and materials
- Supplied fully assembled
- **NEW** 5 year warranty

<b>SUN-TROL1</b>	Vista 10 Trolley - 1 Tray and 1 Shelf
<b>SUN-MPT51</b>	Vista 15 Trolley - 4 Single Depth Trays
<b>SUN-MPT52</b>	Vista 15 Trolley - 2 Single 1 Double Depth Trays
<b>SUN-MPT53</b>	Vista 15 Trolley - 2 Double Depth Trays

			
<b>Sun-LC3A*</b> £49.00 4 Antistatic Castors (front 2 braked)	<b>Sun-BUF2*</b> £31.00 4 Protective Buffers (Vista 10 Trolleys)	<b>Sun-BUF3*</b> £31.00 4 Protective Buffers (Vista 15 Trolleys)	<b>Sun-MPT51*</b> £79.00 Folding Shelf
			
<b>Sun-SBOX1*-**</b> £48.00 Sharps Box Bracket (Daniels) - All Sizes	<b>Sun-MPT-AGH1*</b> £38.00 Alcohol Gel Holder	<b>Sun-GBH1*-**</b> £36.00 Glove Box Holder	<b>Sun-MPT-RAIL1*</b> £27.00 Medi-Rail
			
<b>Sun-MPT-BIN*</b> £25.00 2.5 Litre Bin (requires medi-rail)	<b>Sun-MPT51-LD* ***</b> £123.00 Tamper Resistant Locking Door (Vista 15)	<b>Sun-DIV1</b> £10.00 (per set) Single Depth Tray Dividers (Vista 10/15)	<b>Sun-DIV4</b> £13.00 (per set) Double Depth Tray Dividers (Vista 15)
			
<b>Sun-MPT1-CV</b> £48.00 Trolley Cover (Vista 10)	<b>Sun-MPT51-CV</b> £48.00 Trolley Cover (Vista 15)		

\* these accessories can only be fitted when ordered with trolley \*\* includes medi-rail  
\*\*\* Locking door option includes a secure top and back panel



## Vista® 10 Trolley

Vista 10 Trolley is an economy multi-purpose medical trolley without compromise on quality. Functional, durable & easy to clean

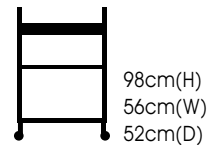

## Vista® 15 Trolley

Vista 15 Trolley has an extra low height (68cm) and is designed to fit under a couch. Functional, durable & easy to clean



tray colours please specify when ordering



## Sunflower VISTA Trolley Range

The Sunflower range of Vista medical trolleys and storage modules is extensive, with options to suit all applications and environments, from GP or hospital consultation and treatment rooms, to hospital wards and intensive care units. The product range is designed to be easy to clean, with smooth lines and minimal dirt traps. Each medical trolley or storage module can be accessorised with medi-rails, sharps box holders, glove box holders, alcohol gel holders, oxygen cylinder holders, laptop holders, and more.

- All Trolleys incorporate our tilt & locking tray runner system
- Trays integrate with all other Vista products
- Locking door option provides tamper resistant security
- Choice of removable single and double depth trays
- Choice of 3 tray colours (Clear, Blue and Green)
- Tray labels and covers included
- 100mm castors with front brakes
- Removable top shelf with integrated upstand
- Easy clean design and materials
- Supplied fully assembled
- **NEW** 5 year warranty



<b>SUN-MPT10</b>	Vista 30 Trolley - 6 Single Depth Trays
<b>SUN-MPT5</b>	Vista 30 Trolley - 2 Single 2 Double Depth Trays
<b>SUN-MPT6</b>	Vista 30 Trolley - 3 Double Depth Trays
<b>SUN-MPT40</b>	Vista 40 Trolley - 5 Single Depth Trays
<b>SUN-MPT41</b>	Vista 40 Trolley - 3 Single 1 Double Depth Trays
<b>SUN-MPT42</b>	Vista 40 Trolley - 1 Single 2 Double Depth Trays



<b>Sun-LC3A*</b> £49.00 4 Antistatic Castors (front 2 braked)	<b>Sun-BUF2*</b> £31.00 4 Protective Buffers (Vista 30 Trolleys)	<b>Sun-BUF3*</b> £31.00 4 Protective Buffers (Vista 40 Trolleys)	<b>Sun-MPTS1*</b> £79.00 Folding Shelf
--	---	---	--



<b>Sun-SBOX1*-**</b> £48.00 Sharps Box Bracket (Daniels) - All Sizes	<b>Sun-MPT-AGH1*</b> £38.00 Alcohol Gel Holder	<b>Sun-GBH1*-**</b> £36.00 Glove Box Holder	<b>Sun-MPT-RAIL1*</b> £27.00 Medi-Rail
---	--	---	--



<b>Sun-MPT-BIN*</b> £25.00 2.5 Litre Bin (requires medi-rail)	<b>Sun-MPT5-LD*-***</b> £131.00 Tamper Resistant Locking Door (Vista 30)	<b>Sun-MPT40-LD*-***</b> £132.00 Tamper Resistant Locking Door (Vista 40)	<b>Sun-DIV1</b> £10.00 (per set) Single Depth Tray Dividers (Vista 40)
--	---	--	---



<b>Sun-DIV2</b> £13.00 (per set) Narrow Double Depth Tray Dividers (Vista 30)	<b>Sun-DIV3</b> £10.00 (per set) Narrow Single Depth Tray Dividers (Vista 30)	<b>Sun-DIV4</b> £13.00 (per set) Double Depth Tray Dividers (Vista 40)	<b>Sun-DIV1</b> £10.00 (per set) Single Depth Tray Dividers (Vista 40)
---	--	---	---



**Sun-MPT40-CV**  
 £48.00  
 Trolley Cover (Vista 40)

\* these accessories can only be fitted when ordered with trolley \*\* includes medi-rail  
 \*\*\* Locking door option includes a secure top and back panel



## Vista® 30 Trolley

Designed for environments with limited space, Vista 30 provides standard working height with compact design, optimum storage, and is functional, durable and easy to clean.



SUN-MPT5-LD

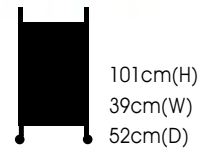

## Vista® 40 Trolley

Designed to fit under a worktop, Vista 40 can be stored neatly away, while providing optimum number of trays for storage, and is functional, durable and easy to clean.

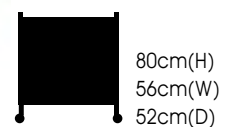

tray colours please specify when ordering



clear

blue

green

## Sunflower VISTA Trolley Range

The Sunflower range of Vista medical trolleys and storage modules is extensive, with options to suit all applications and environments, from GP or hospital consultation and treatment rooms, to hospital wards and intensive care units. The product range is designed to be easy to clean, with smooth lines and minimal dirt traps. Each medical trolley or storage module can be accessorised with medi-rails, sharps box holders, glove box holders, alcohol gel holders, oxygen cylinder holders, laptop holders, and more.

- All Trolleys incorporate our tilt & locking tray runner system
- Trays integrate with all other Vista products
- Locking door option provides tamper resistant security
- Choice of removable single and double depth trays
- Choice of 3 tray colours (Clear, Blue and Green)
- Tray labels and covers included
- 100mm castors with front brakes
- Removable top shelf with integrated upstand
- Easy clean design and materials
- Supplied fully assembled
- **NEW** 5 year warranty



### Vista® 50 Trolley

Suitable for everyday general healthcare use, Vista 50 provides standard working height with generous working space, optimum tray storage, and is functional, durable and easy to clean.



101cm(H)  
56cm(W)  
52cm(D)

<b>SUN-MPT1</b>	Vista 50 Trolley - 6 Single Depth Trays
<b>SUN-MPT2</b>	Vista 50 Trolley - 4 Single 1 Double Depth Trays
<b>SUN-MPT13</b>	Vista 50 Trolley - 3 Double Depth Trays
<b>SUN-MPT55</b>	Vista 55 Trolley - 7 Single Depth Trays
<b>SUN-MPT56</b>	Vista 55 Trolley - 3 Single 2 Double Depth Trays
<b>SUN-MPT57</b>	Vista 55 Trolley - 1 Single 3 Double Depth Trays

### Vista® 55 Trolley

Suitable for everyday general healthcare use, Vista 55 provides standard working height with generous working space, smart design optimises storage with upto seven trays, and is functional, durable and easy to clean.



110cm(H)  
56cm(W)  
52cm(D)

<b>Sun-LC3A*</b> £49.00	<b>Sun-BUF2*</b> £31.00	<b>Sun-MPTS1*</b> £79.00	<b>Sun-MPT-AGH1*</b> £38.00
4 Antistatic Castors (front 2 braked)	4 Protective Buffers	Folding Shelf	Alcohol Gel Holder
<b>Sun-SBOX1*-**</b> £48.00	<b>Sun-GBH1*-**</b> £36.00	<b>Sun-MPT-RAIL1*</b> £27.00	<b>Sun-MPT-BIN*</b> £25.00
Sharps Box Bracket (Daniels) - All Sizes	Glove Box Holder	Medi-Rail	2.5 Litre Bin (requires medi-rail)
<b>Sun-MPT1-LD*-***</b> £132.00	<b>Sun-MPT55-LD*-***</b> £144.00	<b>Sun-DIV1</b> £10.00 (per set)	<b>Sun-DIV4</b> £13.00 (per set)
Tamper Resistant Locking Door (Vista 50)	Tamper Resistant Locking Door (Vista 55)	Single Depth Tray Dividers	Double Depth Tray Dividers
<b>Sun-MPT1-CV</b> £48.00	<b>Sun-MPT55-CV</b> £55.00	<b>Sun-MPT-OXY1*-**</b> £91.00	<b>Sun-MPT-DRIP1*-**</b> £128.00
Trolley Cover (Vista 50)	Trolley Cover (Vista 55)	Oxygen Bottle Holder (Size D)	Drip Stand Attachment

tray colours please specify when ordering



\* these accessories can only be fitted when ordered with trolley \*\* includes medi-rail  
\*\*\* Locking door option includes a secure top and back panel



## Sunflower VISTA Trolley Range

The Sunflower range of Vista medical trolleys and storage modules is extensive, with options to suit all applications and environments, from GP or hospital consultation and treatment rooms, to hospital wards and intensive care units. The product range is designed to be easy to clean, with smooth lines and minimal dirt traps. Each medical trolley or storage module can be accessorised with medi-rails, sharps box holders, glove box holders, alcohol gel holders, oxygen cylinder holders, laptop holders, and more.

- All Trolleys incorporate our tilt & locking tray runner system
- Trays integrate with all other Vista products
- Locking door option provides tamper resistant security
- Choice of removable single and double depth trays
- Choice of 3 tray colours (Clear, Blue and Green)
- Tray labels and covers included
- 100mm castors with front brakes
- Removable top shelf with integrated upstand
- Easy clean design and materials
- Supplied fully assembled
- **NEW** 5 year warranty



### Vista® 60 Trolley

Designed to optimise storage where space is limited, Vista 60 provides additional working space and compact storage with upto 12 trays, and is functional, durable and easy to clean.

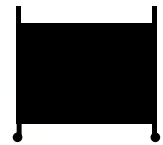

101cm(H)  
70cm(W)  
52cm(D)

<b>SUN-MPT60</b>	Vista 60 Trolley - 12 Single Depth Trays
<b>SUN-MPT61</b>	Vista 60 Trolley - 6 Single 3 Double Depth Trays
<b>SUN-MPT62</b>	Vista 60 Trolley - 6 Double Depth Trays
<b>SUN-MPT16</b>	Vista 100 Trolley - 12 Single Depth Trays
<b>SUN-MPT4</b>	Vista 100 Trolley - 8 Single 2 Double Depth Trays
<b>SUN-MPT17</b>	Vista 100 Trolley - 6 Single 3 Double Depth Trays



**Sun-LC3A\***  
£49.00

4 Antistatic Castors  
(front 2 braked)



**Sun-BUF2\***  
£31.00

4 Protective Buffers



**Sun-MPTS1\***  
£79.00

Folding Shelf



**Sun-MPT-AGH1\***  
£38.00

Alcohol Gel Holder



**Sun-SBOX1\*\***  
£48.00

Sharps Box Bracket  
(Daniels) - All Sizes



**Sun-GBH1\*\***  
£36.00

Glove Box Holder



**Sun-MPT-RAIL1\***  
£27.00

Medi-Rail



**Sun-MPT-BIN\***  
£25.00

2.5 Litre Bin  
(requires medi-rail)



**Sun-MPT60-LD\*\*\***  
£200.00

Tamper Resistant  
Locking Doors (Vista 60)



**Sun-MPT4-LD\*\*\***  
£227.00

Tamper Resistant  
Locking Doors (Vista 100)



**Sun-DIV1**  
£10.00 (per set)

Single Depth Tray  
Dividers (Vista 100)



**Sun-DIV2**  
£13.00 (per set)

Narrow Double Depth  
Tray Dividers (Vista 60)



**Sun-DIV3**  
£10.00 (per set)

Narrow Single Depth Tray  
Dividers (Vista 60)



**Sun-DIV4**  
£13.00 (per set)

Double Depth Tray  
Dividers (Vista 100)



**Sun-MPT-OXY1\*\***  
£91.00

Oxygen Bottle Holder  
(Size D)



**Sun-MPT-DRIP1\*\***  
£128.00

Drip Stand Attachment



**Sun-MPT60-CV**  
£60.00

Trolley Cover  
(Vista 60)



**Sun-MPT4-CV**  
£80.00

Trolley Cover  
(Vista 100)

\* these accessories can only be fitted when ordered with trolley \*\* includes medi-rail  
\*\*\* Locking door option includes a secure top and back panel

### Vista® 100 Trolley

Designed for the most demanding healthcare environments, Vista 100 combines maximum working space with optimum tray storage, and is functional, durable and easy to clean.



101cm(H)  
103cm(W)  
52cm(D)

tray colours please specify when ordering



## Sunflower VISTA Colour Concept Clinical Trolleys

Designed for clinical and disinfecting environments, Vista Clinical are colour designated for clean and dirty areas. Vista 50 provides standard working height with maximum tray storage, while Vista 40 fits neatly under a worktop, both are fully secure, functional, durable and easy to clean.

- Tilt & locking tray runner system
- Trays integrate with all other Vista products
- Removable top shelf with integrated upstand
- Included Tamper resistant locking door
- Top, bottom and back panels provide added security
- Translucent tray lids, tray labels and covers
- Removable top shelf with integrated upstand
- Clean & Dirty labels included
- 100mm castors with front brakes
- 4 Protective buffers as standard
- Front mounted stainless steel handle (Vista 40 only)
- Easy clean design and materials
- **NEW** 5 year warranty

**SUN-CMPT40B** Vista 40 Blue Colour Concept Clinical Trolley - 5 Single Depth Trays

**SUN-CMPT40C** Vista 40 White Colour Concept Clinical Trolley - 5 Single Depth Trays

**SUN-CMPT40R** Vista 40 Red Colour Concept Clinical Trolley - 5 Single Depth Trays

**SUN-CMPT1B** Vista 50 Blue Colour Concept Clinical Trolley - 6 Single Depth Trays

**SUN-CMPT1C** Vista 50 White Colour Concept Clinical Trolley - 6 Single Depth Trays

**SUN-CMPT1R** Vista 50 Red Colour Concept Clinical Trolley - 6 Single Depth Trays



**Sun-LC3A\***  
£49.00

4 Antistatic Castors  
(front 2 braked)



**Sun-MPTS1\***  
£79.00

Folding Shelf



**Sun-MPT-AGH1\***  
£38.00

Alcohol Gel Holder



**Sun-GBH1\*-\*\***  
£36.00

Glove Box Holder



**Sun-SBOX1\*-\*\***  
£48.00

Sharps Box Bracket  
(Daniels) - All Sizes



**Sun-MPT-RAIL1\***  
£27.00

Medi-Rail

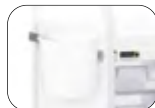

**Sun-MPT-BIN\***  
£25.00

2.5 Litre Bin  
(requires medi-rail)



**Sun-DIV1**  
£10.00 (per set)

Single Depth Tray  
Dividers



**Sun-MPT40-CV**  
£60.00

Trolley Cover  
(Vista 40)



**Sun-MPT1-CV**  
£48.00

Trolley Cover  
(Vista 50)



**Sun-MPT-OXY1\*-\*\***  
£91.00

Oxygen Bottle  
Holder (Size D) Vista 50



**Sun-MPT-DRIP1\*-\*\***  
£128.00

Drip Stand  
Attachment Vista 50

\* these accessories can only be fitted when ordered with trolley \*\* includes medi-rail

\*\*\* Locking door option includes a secure top and back panel



### Vista® 40 Clinical Trolley

Vista 40 colour concept clinical trolley - 5 single trays with optional sharps box holder and folding shelf

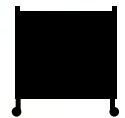

80cm(H)  
64cm(W)  
60cm(D)  
with buffers

### Vista® 50 Clinical Trolley

Vista 50 colour concept clinical trolley - 6 single trays with optional sharps box holder, glove box holder and folding shelf

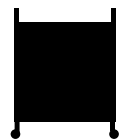

101cm(H)  
64cm(W)  
60cm(D)  
with buffers

frame & tray colours please specify when ordering



blue



white/clear



red

## Sunflower VISTA Clinical Trolleys

Vista Clinical Trolleys are a mobile storage solution for every healthcare environment, incorporating a removable recessed stainless steel tray, buffers as standard, using premium materials which are easy to clean.

- Tilting & locking tray runner system
- Trays integrate with all other Vista products
- Removable mirror polished recessed stainless steel tray (304 grade)
- Locking door option provides tamper resistant security
- Choice of removable single and double depth trays
- Choice of 3 tray colours (Clear, Blue and Green)
- Tray labels and covers included
- 100mm castors with front brakes
- Easy clean design and materials
- Supplied fully assembled
- **NEW** 5 year warranty



### Vista® 30 Clinical Trolley

Designed for environments with limited space, Vista 30 Clinical provides standard working height with compact design, optimum storage, a removable recessed stainless steel tray and is functional, durable and easy to clean.



101cm(H)  
47cm(W)  
60cm(D)  
with buffers

SUN-CVT30-LD

<b>SUN-CVT30</b>	Vista 30 Clinical Trolley - 6 Single Depth Trays
<b>SUN-CVT31</b>	Vista 30 Clinical Trolley - 2 Single 2 Double Depth Trays
<b>SUN-CVT32</b>	Vista 30 Clinical Trolley - 3 Double Depth Trays
<b>SUN-CVT40</b>	Vista 40 Clinical Trolley - 5 Single Depth Trays
<b>SUN-CVT41</b>	Vista 40 Clinical Trolley - 3 Single 1 Double Depth Trays
<b>SUN-CVT42</b>	Vista 40 Trolley - 1 Single 2 Double Depth Trays



**Sun-LC3A\***  
£49.00

4 Antistatic Castors  
(front 2 braked)



**Sun-MPTS1\***  
£79.00

Folding Shelf



**Sun-SBOX1\*-\*\***  
£48.00

Sharpes Box Bracket  
(Daniels) - All Sizes



**Sun-MPT-AGH1\***  
£38.00

Alcohol Gel Holder



**Sun-GBH1\*-\*\***  
£36.00

Glove Box Holder

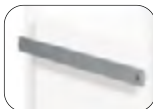

**Sun-MPT-RAIL\***  
£27.00

Medi-Rail



**Sun-MPT-BIN\***  
£25.00

2.5 Litre Bin  
(requires medi-rail)



**Sun-CVT30-LD\*-\*\*\***  
£131.00

Tamper Resistant  
Locking Door (Vista 30)



**Sun-CVT40-LD\*-\*\*\***  
£132.00

Tamper Resistant  
Locking Door (Vista 40)



**Sun-DIV1**  
£10.00 (per set)

Single Depth Tray  
Dividers (Vista 40)



**Sun-DIV2**  
£13.00 (per set)

Narrow Double Depth  
Tray Dividers (Vista 30)



**Sun-DIV3**  
£10.00 (per set)

Narrow Single Depth  
Tray Dividers (Vista 40)



**Sun-DIV4**  
£13.00 (per set)

Double Depth Tray  
Dividers (Vista 40)



**Sun-MPT5-CV**  
£48.00

Trolley Cover  
(Vista 30)



**Sun-MPT40-CV**  
£48.00

Trolley Cover  
(Vista 40)

### Vista® 40 Clinical Trolley

Designed to fit under a worktop, Vista 40 Clinical can be stored neatly away, while providing optimum number of trays for storage, removable recessed stainless steel tray and is functional, durable and easy to clean.



80cm(H)  
64cm(W)  
60cm(D)  
with buffers

tray colours please specify when ordering



clear



blue



green

\* These accessories can only be fitted when ordered with trolley

\*\* Includes medi-rail

\*\*\* Locking door option includes a secure top and back panel

## Sunflower VISTA Clinical Trolleys

Vista Clinical Trolleys are a mobile storage solution for every healthcare environment, incorporating a removable recessed stainless steel tray, buffers as standard, using premium materials which are easy to clean.

- Tilting & locking tray runner system
- Trays integrate with all other Vista products
- Removable mirror polished recessed stainless steel tray (304 grade)
- Locking door option provides tamper resistant security
- Choice of removable single and double depth trays
- Choice of 3 tray colours (Clear, Blue and Green)
- Tray labels and covers included
- 100mm castors with front brakes
- Easy clean design and materials
- Supplied fully assembled
- **NEW** 5 year warranty



### Vista® 50 Clinical Trolley

Suitable for everyday general healthcare use, Vista 50 Clinical provides standard working height with generous working space, optimum tray storage, removable recessed stainless steel tray and is functional, durable and easy to clean.

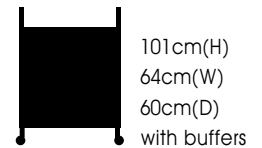

<b>SUN-CVT50</b>	Vista 50 Clinical Trolley - 6 Single Depth Trays
<b>SUN-CVT51</b>	Vista 50 Clinical Trolley - 4 Single 1 Double Depth Trays
<b>SUN-CVT52</b>	Vista 50 Clinical Trolley - 3 Double Depth Trays
<b>SUN-CVT60</b>	Vista 60 Clinical Trolley - 12 Single Depth Trays
<b>SUN-CVT61</b>	Vista 60 Clinical Trolley - 6 Single 3 Double Depth Trays
<b>SUN-CVT62</b>	Vista 60 Trolley - 6 Double Depth Trays

 <b>Sun-LC3A*</b> £49.00 4 Antistatic Castors (front 2 braked)	 <b>Sun-MPTS1*</b> £79.00 Folding Shelf	 <b>Sun-SBOX1*-**</b> £48.00 Sharps Box Bracket (Daniels) - All Sizes	 <b>Sun-MPT-AGH1*</b> £38.00 Alcohol Gel Holder
 <b>Sun-GBH1*-**</b> £36.00 Glove Box Holder	 <b>Sun-MPT-RAIL*</b> £27.00 Medi-Rail	 <b>Sun-MPT-BIN*</b> £25.00 2.5 Litre Bin (requires medi-rail)	 <b>Sun-CVT50-LD*-***</b> £136.00 Tamper Resistant Locking Door (Vista 50)
 <b>Sun-CVT60-LD*-***</b> £200.00 Tamper Resistant Locking Doors (Vista 60)	 <b>Sun-DIV1</b> £10.00 (per set) Single Depth Tray Dividers (Vista 50)	 <b>Sun-DIV2</b> £13.00 (per set) Narrow Double Depth Tray Dividers (Vista 60)	 <b>Sun-DIV3</b> £10.00 (per set) Narrow Single Depth Tray Dividers (Vista 60)
 <b>Sun-DIV4</b> £13.00 (per set) Double Depth Tray Dividers (Vista 50)	 <b>Sun-MPT1-CV</b> £48.00 <b>Sun-MPT60-CV</b> £60.00 Trolley Covers (Vista 50 & 60)	 <b>Sun-MPT-OXY1*-**</b> £91.00 Oxygen Bottle Holder (Size D)	 <b>Sun-MPT-DRIP1*-**</b> £128.00 Drip Stand Attachment

### Vista® 60 Clinical Trolley

Designed to optimise storage where space is limited, Vista 60 Clinical provides additional working space with compact storage using upto 12 trays, removable recessed stainless steel tray and is functional, durable and easy to clean.

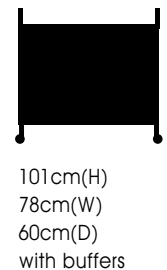

tray colours please specify when ordering



\* These accessories can only be fitted when ordered with trolley  
\*\* Includes medi-rail  
\*\*\* Locking door option includes a secure top and back panel

# Sunflower Ward Drug and Medicine Dispensing Trolleys

Designed to provide a complete solution for storing, distributing and dispensing medicine and drugs. Ward drug and medicine dispensing trolleys are aesthetically pleasing, hygienically designed and combine smart adjustable internal storage with easy access, while being functional, strong, secure and easy to clean.

- Lightweight easy to manoeuvre design
- Adjustable shelf divider system - 5 compartments per shelf
- Adjustable cabinet base divider system - 16 compartments
- Hinged lid with slam lock & protective lock escutcheon
- Lock supplied with 2 keys - keyed to differ\*
- Shelf labels supplied
- Gas assisted lid opening and retention
- Hygienic stainless steel handle and fittings
- Fold down work surface
- Lift up side table
- 4 removable tray positions (2 trays supplied)
- Patient notes/file retention strap
- Push pull handle (to 3 sides)
- Four 100mm braked castors with four protective buffers
- Security leash and wall fixing bracket
- Laminate faced MDF with 2mm edging
- Easy clean design and materials
- Supplied fully assembled
- **NEW** 5 year warranty

\* Keyed to differ as specified by NHS England (keyed to differ means each trolley has its own unique set of keys)

**SUN-WDT20-KD** Ward Drug and Medicine Dispensing Trolley (medium capacity) Divider System and 2 Storage Trays

**SUN-WDT50-KD** Ward Drug and Medicine Dispensing Trolley (large capacity) Divider System and 2 Storage Trays

**SUN-WDT-KD-KEY\*** Additional Keys

**SUN-WDT-SBOX1\*-\*\*** Sharpes Box Bracket (Daniels - All Sizes)

**SUN-WDT-DIV1** Additional Divider Kit (5 Shelf Dividers, 10 Base Dividers, 10 Labels and Clips)

**SUN-WDT-AGH1\*-\*\*** Alcohol Gel Holder

**SUN-WDT-GBH1\*-\*\*** Glove Box Holder

**SUN-LC3A\*** Antistatic Braked Castors

\*These accessories can only be fitted when ordered with the trolley \*\*Includes Medi-Rail



**SUN-WDT-KD-KEY\***  
Additional Keys



**SUN-WDT-SBOX1\*-\*\***  
Sharpes Box Bracket (Daniels - All Sizes)



**SUN-WDT-DIV1**  
Additional Divider Kit



**SUN-WDT-AGH1\*-\*\***  
Alcohol Gel Holder



**SUN-WDT-GBH1\*-\*\***  
Glove Box Holder



**SUN-LC3A\***  
Antistatic Braked Castors

\* these accessories can only be fitted when ordered with trolley



Adjustable storage divider system on shelves and cabinet base



Keyed to Differ as required by NHS England



110cm(H) 90cm(W) 58cm(D)  
94cm(W) 60cm(D) with buffers



**SUN-WDT50-KD**

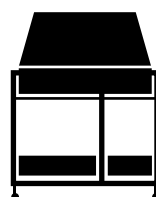

128cm(H) 90cm(W) 58cm(D)  
94cm(W) 60cm(D) with buffers

## Sunflower Unit Dosage System (UDS) Trolleys

Our Unit Dosage System (UDS) Drug Trolleys are available in 2 sizes to accommodate individual patient prescriptions to be stored in their own trays. Strong, secure and hygienically designed, our trolleys are finished in durable beech effect laminate, providing an optimum drug storage and distribution solution for use in hospitals, nursing homes or health care centres.

### SUN-DT7-UDS

- 6 wide trays and 6 tray dividers
- 12 narrow trays and 12 tray dividers
- Standard tray capacity provides 36 compartments
- 3 Adjustable height door shelves

### SUN-DT8-UDS







- 9 wide trays and 9 tray dividers
- 18 narrow trays and 18 tray dividers
- Standard tray capacity provides 54 compartments
- 6 Adjustable height door shelves
- Pull-out clear A4 storage tray

### SUN-DT7-UDS & SUN-DT8-UDS

- 6 Pull out shelves with finger recess
- Fold down work surface
- Slam lock with 2 keys and lock escutcheon
- Integrated cup, pill cup, water jug and pen recess
- Integral shelf for patients record file
- Push and pull handles, bin and media rail
- All-round protective rail and front braked castors
- Easy clean design and materials
- **NEW** 5 year warranty

<b>SUN-DT7-UDS</b>	Unit Dosage System Trolley - Small
<b>SUN-DT8-UDS</b>	Unit Dosage System Trolley - Large
<b>SUN-DT-KEY*</b>	Additional Door Key
<b>SUN-DT-SL</b>	Security Leash and Wall Fixing Bracket
<b>SUN-DT-B25*</b>	Additional 2.5 Litre Bin and Bracket
<b>SUN-DT-AGH1*</b>	Alcohol Gel Holder
<b>SUN-DT-WT</b>	Additional Wide Tray
<b>SUN-DT-NT</b>	Additional Narrow Tray
<b>SUN-DT-WTD</b>	Additional Wide Tray Divider (each)
<b>SUN-DT-WTL</b>	Additional Wide Tray Labels (10 pack)
<b>SUN-DT-NTD</b>	Additional Narrow Tray Divider (each)
<b>SUN-DT-NTL</b>	Additional Narrow Tray Labels (10 pack)

\*These accessories can only be fitted when ordered with the trolley

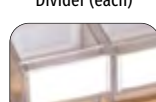
			
<b>SUN-DT-KEY*</b> Additional Door Keys	<b>SUN-DT-SL</b> Security Leash & Wall Fixing Bracket	<b>SUN-DT-B25*</b> Additional 2.5 Litre Bin and Bracket	<b>SUN-DT-AGH1*</b> Alcohol Gel Holder
			
<b>SUN-DT-WT</b> Additional Wide Tray	<b>SUN-DT-WTD</b> Additional Wide Tray Divider (each)	<b>SUN-DT-WTL</b> Additional Wide Tray Labels (10 pack)	<b>SUN-DT-NT</b> Additional Narrow Tray
			
<b>SUN-DT-NTD</b> Additional Narrow Tray Divider (each)	<b>SUN-DT-NTL</b> Additional Narrow Tray Labels (10 pack)		

\* these accessories can only be fitted when ordered with trolley



SUN-DT7-UDS

112cm(H) 62cm(W) 60cm(D)



SUN-DT8-UDS

112cm(H) 82cm(W) 60cm(D)

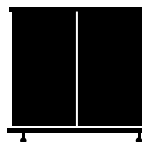

## Sunflower Monitored Dosage System (MDS) Trolleys

Our Monitored Dosage System (MDS) Drug Trolleys are available in 3 sizes to accommodate 4, 6 & 9 blister pack racks (files), and are designed to allow the administration of blister pack drugs as supplied by Boots and Venelink. Strong, secure and hygienically designed, the trolleys are finished in durable beech effect laminate, providing an optimum drug storage and distribution solution for hospitals, nursing homes and health care centres.

- Pull-out shelves with finger recess
- Location channel for holding racks
- Fold down work surface
- 3 Adjustable height door shelves (DT1-MDS4 & DT1-MDS6)
- 6 Adjustable height door shelves (DT2-MDS9)
- Pull-out clear A4 storage tray (DT2-MDS9)
- Slam lock with 2 keys and lock escutcheon
- Integrated cup, pill cup and water jug recess
- Integrated pen recess
- Push and pull handles
- Bin and media-rail
- All round protective rail
- Front push and pull handle
- 100mm castors with front brakes
- Integral shelf for patients record file
- Easy clean design and materials
- Supplied fully assembled
- **NEW** 5 year warranty



<b>SUN-DT1-MDS4</b>	Monitored Dosage System Trolley - Small (4 rack)
<b>SUN-DT1-MDS6</b>	Monitored Dosage System Trolley - Small (6 rack)
<b>SUN-DT2-MDS9</b>	Monitored Dosage System Trolley - Large (9 rack)
<b>SUN-DT-KEY*</b>	Additional Door Key
<b>SUN-DT-SL</b>	Security Leash and Wall Fixing Bracket
<b>SUN-DT-B25*</b>	Additional 2.5 Litre Bin and Bracket
<b>SUN-DT-AGH1*</b>	Alcohol Gel Holder

\*These accessories can only be fitted when ordered with the trolley



**SUN-DT-KEY\***  
Additional Door Keys



**SUN-DT-SL**  
Security Leash & Wall Fixing Bracket



**SUN-DT-B25\***  
Additional 2.5 Litre Bin and Bracket



**SUN-DT-AGH1\***  
Alcohol Gel Holder

\* these accessories can only be fitted when ordered with trolley

## Sunflower Monitored Dosage System (MDS) Self Administration Wall Cabinets

Designed for storage of self administration medicines, our cabinets provide low level security for the Monitored Dosage System (MDS) and are suitable for storing Manrex (Boots) and Venalink systems.

- 2 Sizes - to hold 1 or 2 MDS rack brackets
- Integrated shelf
- High quality 18mm beech effect construction
- Locking door (2 keys supplied)
- **NEW** 5 year warranty



42cm(H) 30cm(W) 24cm(D)



72cm(H) 40cm(W) 24cm(D)

<b>SUN-MDSCAB1</b>	Self Administration Cabinet - 1 Rack Bracket and 1 Shelf
<b>SUN-MDSCAB1/KD</b>	Self Administration Cabinet - 1 Rack Bracket and 1 Shelf (Keyed to differ)
<b>SUN-MDSCAB2</b>	Self Administration Cabinet - 2 Rack Brackets and 1 Shelf
<b>SUN-MDSCAB2/KD</b>	Self Administration Cabinet - 2 Rack Brackets and 1 Shelf (Keyed to differ)



**SUN-DT1-MDS4**



112cm(H)  
62cm(W)  
60cm(D)



**SUN-DT1-MDS6**



112cm(H)  
62cm(W)  
60cm(D)



**SUN-DT2-MDS9**

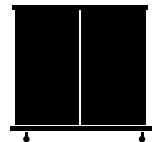

112cm(H)  
82cm(W)  
60cm(D)



**SUN-MDSCAB1**



**SUN-MDSCAB2**



## Doherty Howarth Trolley Range

The Doherty Howarth Trolley Range has been designed to provide easy to use storage for the modern practice. They are manufactured using a combination of modern and traditional materials to provide a robust trolley with a modern look and feel.

There are 4 trolleys in the range with a choice of white or 3 other colour finishes. The range is designed to coordinate with the Doherty couch ranges and the new Doherty solid panel screen system.



- Easy to clean, hygienic construction combining an epoxy coated white frame with high specification fire retardant plastic panels and trays
- Removable top and bottom shelves
- Interchangeable shallow and deep translucent trays
- Spare trays available to purchase as accessories
- Useful additional bottom shelf to provide further storage
- High quality 75mm twin wheel castors (2 front braked)
- Supplied fully assembled and ready for use



**Colour Choice:**  
Blue, grey or white



**Trolleys:**

<b>HCF520</b>	Howarth Trolley A - White
<b>HCF521</b>	Howarth Trolley B - White
<b>HCF522</b>	Howarth Trolley C - White
<b>HCF523</b>	Howarth Trolley D - White
<b>HCF524</b>	Howarth Trolley A - Select Colour
<b>HCF525</b>	Howarth Trolley B - Select Colour
<b>HCF526</b>	Howarth Trolley C - Select Colour
<b>HCF527</b>	Howarth Trolley D - Select Colour



**Trolley A**  
4 shallow & 1 deep trays.  
Full width trolley.

**Size:** 96 x 57 x 45cm



**Trolley B**  
4 shallow & 1 deep trays.  
Narrow width trolley.

**Size:** 96 x 40 x 45cm



**Trolley C**  
2 shallow & 1 deep tray.  
Fits under work surfaces.

**Size:** 62 x 57 x 45cm



**Trolley D**  
3 Shelves & 1 shallow tray.  
Basic full width trolley.

**Size:** 96 x 56.5 x 45cm

**Trays:**

<b>HCF528</b>	Narrow Shallow Tray
<b>HCF529</b>	Narrow Deep Tray
<b>HCF530</b>	Wide Shallow Tray
<b>HCF531</b>	Wide Deep Tray

**Trays Dividers:**

<b>HCF536</b>	Tray Divider 1 - 288 x 210 x 60mm
<b>HCF537</b>	Tray Divider 4 - 288 x 210 x 60mm

## Doherty Hastings Trolley

- Stainless steel frame
- Stainless Steel shelves with rounded and cut out corners for safety and ease of cleaning
- Swivelling anti-static castors for safety and ease of manoeuvrability



<b>HCF111</b>	Trolley - 915 x 460 x 460mm
<b>HCF112</b>	Trolley - 915 x 610 x 460mm
<b>HCF113</b>	Trolley - 915 x 765 x 460mm

## Doherty Halifax/Harrogate Trolleys

- Mild Steel Frame
- Aluminium or Stainless Steel shelves with rounded and cut out corners for safety and ease of cleaning
- Swivelling anti-static castors for safety and ease of manoeuvrability
- Anti-static rubber shelf supports



<b>HCF581</b>	Halifax Aluminium Shelves - 915 x 460 x 460mm
<b>HCF582</b>	Halifax Aluminium Shelves - 915 x 610 x 460mm
<b>HCF583</b>	Halifax Aluminium Shelves - 915 x 765 x 460mm
<b>HCF584</b>	Harrogate Mild Steel Shelves - 915 x 460 x 460mm
<b>HCF585</b>	Harrogate Mild Steel Shelves - 915 x 610 x 460mm



## Chrome Wire Shelving

- Wire shelving which is able to change as quickly as your needs change to suit your requirements
- Shelf Ribs run from front to back, allowing you to slide items on and off shelves smoothly
- Shelves can be loaded/unloaded easily from all sides
- Shelves can be adjusted at 25mm intervals along rail
- Available in a vast array of sizes
- Castors add 150mm to height
- Castors allow the shelving to be easily manouvered and relocated when needed



<b>HCF1231</b>	455mm x 914mm x 1590mm
<b>HCF1232</b>	455mm x 1220mm x 1590mm
<b>HCF1233</b>	455mm x 1525mm x 1590mm
<b>HCF1234</b>	610mm x 914mm x 1590mm
<b>HCF1235</b>	610mm x 1220mm x 1590mm
<b>HCF1236</b>	610mm x 1525mm x 1590mm
<b>HCF1237</b>	Set of 4 125mm Dia Castors (2 Braked)

## Metromax Q Polymer Mat Shelving

- Durable polymer mats that remove for easy cleaning and protect stored items from damage
- Quick and easy to assemble or adjust, the patented corner release allows shelves to be unlocked without tools
- Microban antimicrobial product protection is built into the high contact areas of the shelf
- Available in a vast array of sizes
- Castors add 150mm to height
- Castors allow the shelving to be easily manouvered and relocated when needed



<b>HCF1238</b>	455mm x 914mm x 1590mm
<b>HCF1239</b>	455mm x 1220mm x 1590mm
<b>HCF1240</b>	455mm x 1525mm x 1590mm
<b>HCF1241</b>	610mm x 914mm x 1590mm
<b>HCF1242</b>	610mm x 1220mm x 1590mm
<b>HCF1243</b>	610mm x 1525mm x 1590mm
<b>HCF1237</b>	Set of 4 125mm Dia Castors (2 Braked)

## Metro Suture Cart

- Slanted shelves present contents for instant identification and access
- Allows logical organization, eliminates confusion, makes ordering easy
- Five slanted shelves
- Shelves slant at a 45° angle
- Includes package of 12 retainers
- Packed weight: 51–55kg



<b>HCF894</b>	457 x 610 x 1778mm Cart
<b>HCF894.1</b>	457 x 914 x 1778mm Cart
<b>HCF895</b>	457 x 1220 x 1778mm Cart

## Metro Catheter Cart



Catheter Bulk Style Carts	Combination Style Carts
• Selection x 610 x 1727mm	• Selection x 610 x 1727mm
• 4 Bars 60" & 6 Bins	• 3 Side Shelves 24" & 4 Bars 36"
• Max 17 hooks per bar	• Max of 9 hooks per bar
<b>HCF1244</b>	Bulk 1220mm Wide, 32 Hooks
<b>HCF1245</b>	Bulk 1525mm Wide, 40 Hooks
<b>HCF1246</b>	Cart Combi. 1525mm Wide, 16 Hooks
<b>HCF1247</b>	Cart Combi. 1525mm Wide, 24 Hooks

## Starsys Catheter Carts

Designed for environments where aesthetics are important and cleanliness is essential. Starsys is an organized system that meet demands for storage, transport and productivity.

### Single Width Mobile Shell

- 1 Catheter Shelf
- 3 Catheter Slides & 30 label
- 15 Catheter Hooks
- Left-hinged 270° tall solid door with M300 series keylock & 2 keys
- Taupe Door Pull
- **Capacity:** 180 catheters (300 with an extra 15 hooks)
- Maximum Length: 1575mm
- **Size:** 1991 x 577 x 633mm



**HCF1248** Single Width Cart

The Starsys catheter storage module is a high density storage solution, which provides quick access and retrieval, visual inventory and easy identification.

### Double Width Mobile Shell

- 2 Catheter Shelves
- 6 Catheter Slides & 60 labels
- 30 Catheter Hooks
- Left-hinged 270° tall solid door with M300 series keylock & 2 keys
- Right-hinged 270° tall solid door with M300 series keylock & 2 keys
- Taupe Door Pulls
- **Capacity:** 360 catheters (720 with an additional 30 hooks)
- Maximum Length: 1575mm
- **Size:** 1991 x 1080 x 633mm



**HCF1249** Double Width Cart

## BC Deep Ledge Carts

- Smooth and easy to clean polymer surfaces
- Higher ergonomic push handle
- Center shelf adjusts on 1" increments (3 Shelf)
- Microban coating in aesthetic Blue colour
- Easily manoeuvred on castors
- Sturdy metal framing
- Simple to clean and maintain
- 2 and 3 shelf models, in 2 varying sizes

**HCF1203** 546 x 832 x 1041mm - 2 Shelf

**HCF1207** 546 x 832 x 1041mm - 3 Shelf



**HCF1215** 685 x 984 x 1041mm - 2 Shelf

**HCF1218** 685 x 984 x 1041mm - 3 Shelf

## myCart™

- Contoured handle for control and built in tray for small items
- Corrosion proof shelves with shelf cutaway for leg clearance
- Smooth rounded corners for easy cleaning
- Advanced polymers and chrome plated posts
- Available with Microban® antimicrobial product protection
- The utility tray offers 2x the amount of space than conventional service carts; which allows for objects to fit well
- 300 lb., 400 lb., and 500 lb. capacity models available



**HCF1190** 2030 2-Shelf with Chrome Plated Posts (Blue)

**HCF1191** 2030 3-Shelf with Chrome Plated Posts (Blue)

**HCF1192** 2636 2-Shelf with Chrome Plated Posts (Blue)

**HCF1193** 2636 3-Shelf with Chrome Plated Posts (Blue)

## MW Utility Carts

Offer a level of versatility and durability you'll find nowhere else. Metro carts are ergonomically-designed for low-effort transport, and give the handling required to manoeuvre in close quarters.

- Carts are offered as complete units, shipped knocked down, with all components packaged in a compact carton.
- Easy to assemble, relocation of shelves is quick and simple.
- Chrome finish - available as 2 or 3 tier models
- **Dimensions:**  
2 Tier: 455 x 610 x 880mm  
3 Tier: 455 x 914 x 880mm



**HCF1093** 2 Tier - 610mm Wide

**HCF1097** 2 Tier - 914mm Wide

**HCF1250** 3 Tier - 610mm Wide

**HCF1251** 3 Tier - 914mm Wide



HCF1562



HCF1563



HCF1565

## General Purpose Trolleys

Trolley is robust and self-supporting, ideal for transportation solutions across the medical industry.

Catering for a varied range of needs & purposes across working environments. These multi-functional trolleys are an essential part of any medical setting.

- 40mm raised edges on each shelf
- Mounted on 4x 100mm swivel castors
- Protective buffers included
- Lipped shelves to secure contents
- Push handles at either end for manoeuvrability
- Select from stainless steel or mild steel construction
- **Trolley dimensions:** 935 x 510 x 1015mm

### Shuttleworth



Made in the  
UK Since 1953

**HCF1562** Stainless Steel Two Shelf Trolley

**HCF1563** Stainless Steel Three Shelf Trolley

**HCF1564** Mild Steel Two Shelf Trolley

**HCF1565** Mild Steel Three Shelf Trolley

## Stainless Steel Dressing Trolleys

Our range of Dressing Trolleys are available in four sizes, each is easily cleaned and hygienic. Manufactured to a high specification with 1.5mm 16SWG SS 304 grade stainless steel.

There are options for a flat or curved up edge shelf design which is ideal for use in medical environments including GP surgeries, hospitals and health centres.

- Manufactured from 304 grade stainless steel
- Two fixed shelves included
- Mounted on 4x 100mm swivel castors
- Option of either flat or edged-up shelves
- Also available in mild steel

### Shuttleworth



Made in the  
UK Since 1953



HCF1574



HCF1580



HCF1577

#### Fixed Shelf Trolleys:

**HCF1566** Small 460 x 460 x 917mm – Edged-up Shelves

**HCF1567** Medium 610 x 460 x 917mm – Edged-up Shelves

**HCF1568** Large 760 x 460 x 915mm – Edged-up Shelves

**HCF1569** XL 920 x 460 x 915mm – Edged-up Shelves

**HCF1570** XXL 1220 x 460 x 915mm – Edged-up Shelves

**HCF1571** Small 460 x 460 x 917mm – Flat Shelves

**HCF1572** Medium 610 x 460 x 917mm – Flat Shelves

**HCF1573** Large 760 x 460 x 915mm – Flat Shelves

**HCF1574** XL 920 x 460 x 915mm – Flat Shelves

**HCF1575** XXL 1220 x 460 x 915mm – Flat Shelves

#### Removable Shelf Trolleys:

**HCF1576** Small 460 x 460 x 917mm – Edged-up Shelves

**HCF1577** Medium 610 x 460 x 917mm – Edged-up Shelves

**HCF1578** Large 760 x 460 x 915mm – Edged-up Shelves

**HCF1579** XL 920 x 460 x 915mm – Edged-up Shelves

**HCF1580** Small 460 x 460 x 917mm – Flat Shelves

**HCF1581** Medium 610 x 460 x 917mm – Flat Shelves

**HCF1582** Large 760 x 460 x 915mm – Flat Shelves

**HCF1583** XL 920 x 460 x 915mm – Flat Shelves

## Sunflower Dressing Trolleys

Innovative in design, and in use of materials, our range of dressing trolleys provide hygienic mobile support and storage, whilst being functional, durable and easy to clean.

- Unique glass effect safety trays or Stainless steel trays (304 grade/DP2 finish)
- 2 or 3 stainless removable trays
- Lift-off top tray with integral handles
- Hygienically designed raised upstands
- Trays 'locate' around frame to prevent movement
- Tray protection buffer ring
- Durable non-marking 75mm castors
- Durable epoxy coated white frame
- Optional drawers available in a choice of 2 finishes
- 10kg Maximum individual tray load
- Easy clean design and materials
- Supplied fully Assembled
- **NEW** 5 year warranty

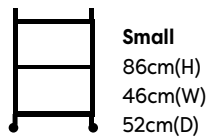

<b>SUN-DT4G2</b>	Dressing Trolley - 2 Glass Effect Safety Trays
<b>SUN-DT4G3</b>	Dressing Trolley - 3 Glass Effect Safety Trays
<b>SUN-DT4S2</b>	Dressing Trolley - 2 Stainless Steel Trays
<b>SUN-DT4S3</b>	Dressing Trolley - 3 Stainless Steel Trays
<b>SUN-DT4DW*</b>	Single Drawer Unit - White Finish
<b>SUN-DT4DT*</b>	Single Drawer Unit - Titanium Finish
<b>SUN-DTDT1</b>	Drawer Insert

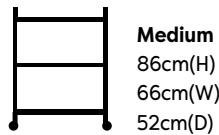

<b>SUN-DT6G2</b>	Dressing Trolley - 2 Glass Effect Safety Trays
<b>SUN-DT6G3</b>	Dressing Trolley - 3 Glass Effect Safety Trays
<b>SUN-DT6S2</b>	Dressing Trolley - 2 Stainless Steel Trays
<b>SUN-DT6S3</b>	Dressing Trolley - 3 Stainless Steel Trays
<b>SUN-DT6DW*</b>	Single Drawer Unit - White Finish
<b>SUN-DT6DT*</b>	Single Drawer Unit - Titanium Finish
<b>SUN-DTDT2</b>	Drawer Insert

<b>SUN-BUF1*</b>	Protective Buffers (set of 4)
<b>SUN-LC1*</b>	2 Front Braked Castors
<b>SUN-LC1A*</b>	4 Antistatic Castors (front 2 braked)

\* these accessories can only be fitted when ordered with trolley



SUN-DT4S3 with  
SUN-DT4DW



SUN-DT4G2



SUN-DT6G3



SUN-DT6S2

**drawer unit finishes** please specify when ordering



White  
(high gloss)



Titanium  
(high gloss)

## Sunflower Surgical Trolleys Mirror Polished

Premium use of materials, and finished to the highest standard, our range of 'mirror polished' surgical trolleys provide hygienic mobile support for clinical environments and theatres, whilst being functional, durable and easy to clean.

- Stainless steel shelves, trays and frame (304 grade)
- Mirror polished stainless steel shelves, trays and frame
- Fully welded seamless frame
- Designed to comply with the requirements of the hospital market (BS4068 : 1977)
- Flat, fixed or removable/reversible shelves
- Mirror polished lift off flat shelves (Sun-STFW/RFS2 only)
- Removable, reversible folded shelves (Sun-STFW/RRFS2 only)
- Fully welded fixed shelves (Sun-STFW/FFS2 only)
- Anti-static shelf/tray protection buffers
- 75mm antistatic castors
- 4 Protective buffers
- 10kg Maximum individual tray load
- Easy clean design and materials
- Supplied fully Assembled
- **NEW 5 year warranty**



**SUN-STFW7-RRFS2**  
Surgical Trolley - 2 Removable Reversible Flat Shelves (flange up or down)

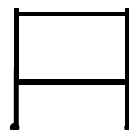

**Large**  
86cm(H)  
75cm(W)  
45cm(D)  
83cm(W)  
53cm(D) with buffers



**SUN-STFW7-FFS2**  
Surgical Trolley - 2 Fully Welded Fixed Shelves (flange down)



**SUN-STFW4-RRFS2**  
Surgical Trolley - 2 Removable Reversible Flat Shelves (flange up or down)

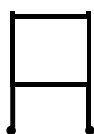

**Small**  
86cm(H)  
45cm(W)  
45cm(D)  
53cm(W)  
53cm(D) with buffers



**SUN-STFW4-FFS2**  
Surgical Trolley - 2 Fully Welded Fixed Shelves (flange down)



**SUN-STFW9-RRFS2**  
Surgical Trolley - 2 Removable Reversible Flat Shelves (flange up or down)

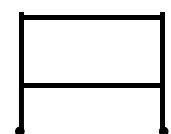

**Extra Large**  
86cm(H)  
91cm(W)  
45cm(D)  
99cm(W)  
53cm(D) with buffers



**SUN-STFW9-FFS2**  
Surgical Trolley - 2 Fully Welded Fixed Shelves (flange down)

**SUN-STFW4-RRFS2** Surgical Trolley - 2 Removable Reversible Flat Shelves (flange up or down)

**SUN-STFW4-FFS2** Surgical Trolley - 2 Fully Welded Fixed Shelves (flange down)

**SUN-STFW7-RRFS2** Surgical Trolley - 2 Removable Reversible Flat Shelves (flange up or down)

**SUN-STFW7-FFS2** Surgical Trolley - 2 Fully Welded Fixed Shelves (flange down)

**SUN-STFW9-RRFS2** Surgical Trolley - 2 Removable Reversible Flat Shelves (flange up or down)

**SUN-STFW9-FFS2** Surgical Trolley - 2 Fully Welded Fixed Shelves (flange down)

**SUN-LCIA\*** 2 Front Braked Antistatic Castors

## Sunflower Surgical Trolleys

Innovative in design, and in use of materials, our range of surgical trolleys provide hygienic mobile support for clinical environments, whilst being functional, durable & easy to clean.



**SUN-ST4S3**  
Surgical Trolley  
3 Stainless Steel Trays



**SUN-ST6S2SF**  
Surgical Trolley  
1 Stainless Steel Shelf and 1 Tray



**SUN-ST6S3**  
Surgical Trolley  
3 Stainless Steel Trays



**SUN-ST6S3SF**  
Surgical Trolley  
1 Stainless Steel Shelf and 2 Trays

**Dimensions:** Sun-ST4 - 86cm(H) x 46cm(W) x 52cm(D)  
Sun-ST6 - 86cm(H) x 66cm(W) x 52cm(D)

<b>SUN-ST4S2</b>	Surgical Trolley - 2 Stainless Steel Trays
<b>SUN-ST4S3</b>	Surgical Trolley - 3 Stainless Steel Trays
<b>SUN-ST4S2SF</b>	Surgical Trolley - 1 Stainless Steel Shelf and 1 Tray
<b>SUN-ST4S3SF</b>	Surgical Trolley - 1 Stainless Steel Shelf and 2 Trays
<b>SUN-ST6S2</b>	Surgical Trolley - 2 Stainless Steel Trays
<b>SUN-ST6S3</b>	Surgical Trolley - 3 Stainless Steel Trays
<b>SUN-ST6S2SF</b>	Surgical Trolley - 1 Stainless Steel Shelf and 1 Tray
<b>SUN-ST6S3SF</b>	Surgical Trolley - 1 Stainless Steel Shelf and 2 Trays
<b>SUN-BUF1*</b>	Protective Buffers (set of 4)
<b>SUN-LC1*</b>	2 Front Braked Castors
<b>SUN-LCIA*</b>	4 Antistatic Castors (front 2 braked)

\* these accessories can only be fitted when ordered with trolley

- Stainless steel trays (304 grade/DP2 finish)
- Lift off top tray with integral handles or removable shelf
- Hygienically designed raised upstands
- Trays 'locate' around frame to prevent movement
- Tray/Shelf protection buffer ring
- Durable non-marking 75mm castors
- Polished stainless steel frame (304 grade)
- 10kg Maximum individual tray load
- Easy clean design and materials
- Supplied fully Assembled
- **NEW** 5 year warranty



## Operating Theatre Equipment

Designed with hygiene as the main focus, these stainless steel items are featured in almost all operating rooms.

These products are suitable for use in operations taking place in a controlled, sterile area.

Each item can be dismantled for easy cleaning and sterilisation. All are mounted on castors to allow them to be easily manoeuvred to the desired location during use.

- Manufactured from 304 grade stainless steel
- Removable sections for ease of cleaning/sterilisation
- 12 Litre buckets where applicable
- Easily manoeuvred
- Mounted on swivel castors
- Plastering trolley includes raised back shelf with movable dividers as standard.

<b>HCF443</b>	Stainless Steel Plaster Trolley
<b>HCF441</b>	Height Adjustable Mayo Table
<b>HCF341.1</b>	Kick About Bowl with Stand
<b>HCF341.2</b>	Kick About Bucket with Stand
<b>HCF1584</b>	Kick About Bowl with Tall Stand

## Shuttleworth



## provi-Dock

### Docking Cart 'provi-Dock' for the inward patient transport

- Modular construction for easy upgrades to customer needs
- Easy and safe attachment of many equipment forms
- Perfect care of the patient during inward transportation
- **Total size:** appr. 410 x 600 x 1.500 mm (w/o IV-Pole)
- **Total weight:** appr. 50 kg (w/o devices)
- **Medical rails:** 4 pcs. each 25 x 10 x 680 mm
- **Infusion holder:** 4 safety hooks
- **Load capacity:** 2 kg per hook
- **IV-Pole adjustment:** one-hand-safety-adjustment
- **Castors:** 4, 100 mm double castors (2 with brake, 2 antistatic)
- **Bed attachment:** height adjustable docking bar with two carrier hooks (plastic bush of very high quality used for the height adjustment)

**HCF1066** Multipurpose Basket – provi-Dock

**HCF1067** Oxygen Bottle Holder – provi-Dock

**HCF1070** Pump Holder Tube 600mm – provi-Dock

**HCF1071** Grounding Ring – provi-Dock

**HCF1072** Medical Plugboard, 6-plug with cover

**HCF1073** Cable/Tube holder for round tube 38mm

**HCF1074** Cable/Tube holder for medical rails 25 x 10mm



**HCF1065** provi-Dock

## Adjustable IV/Drip Stands

Our drip stands are available as either wall mounted or portable versions. Each stand hook height is easy to adjust, whilst the portable versions provide optimum manoeuvrability throughout healthcare environments.

We have two or four hook versions, plus the option to select a weighted base for increased stability. Each is manufactured from stainless steel to be hygienic and easy to clean.

- CE Marked – Class I Medical Devices
- Conforms to BS3619:1976 Stability requirements for Mobile Infusion
- Manufactured from 304 grade stainless steel
- Five legged aluminium cast base for portable versions
- Adjustable hook heights
- Available with weighted/non-weighted base
- Available mounted on swivel castors with aluminium base of 600mm Ø
- Wall mount option with 4 point fixing for secure mounting
- Two/Four hook options

**Shuttleworth**



Made in the UK Since 1953

**HCF1449** Two Hook, Height Adjustable Drip Stand

**HCF1450** Two Hook, Weighted Base, Height Adjustable Drip Stand

**HCF1451** Two Hook, Wall Mounting, Height Adjustable Drip Stand

**HCF1452** Four Hook, Height Adjustable Drip Stand

**HCF1453** Four Hook, Weighted Base, Height Adjustable Drip Stand



## Sunflower Mobile Drip Stands

Simple, practical, easy to adjust and manoeuvre, our drip stands are suitable for most healthcare environments. We can provide a lightweight design through to ones with heavy duty weighted bases, available in a choice of materials to suit your budget and hygiene requirements.



SUN-IV01



**Sun-IV01**  
160cm - 245cm(H)  
51cm(W)



SUN-IV02

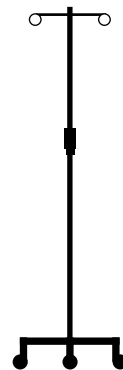

**Sun-IV02**  
160cm - 245cm(H)  
51cm(W)

- 160cm - 245cm Height Range (Sun-IV01 & IV02)
- 156 - 267cm Height Range (Sun-IV08 & IV09)
- Simple locking height adjustment
- Complies with BS3619:1976
- Chrome, aluminium or stainless steel poles
- 2kg hook load or 4kg total
- Lightweight design approx 3kg (Sun-IV01 & IV02)
- Stable 5 star castor base
- Weighted base (Sun-IV08 & IV09)
- Antistatic castors (Sun-IV08 & IV09)
- Simple self assembly required
- Easy clean design and materials
- **NEW** 5 year warranty

<b>SUN-IV01</b>	Chrome Steel Drip Stand, Plastic Base, 2 Plastic Hooks
<b>SUN-IV02</b>	Chrome Steel Drip Stand, Plastic Base, 4 Chrome Hooks
<b>SUN-IV08</b>	Brushed Stainless Steel Drip Stand and Weighted Base, 2 Chrome Hooks, Anti-Static Castors
<b>SUN-IV09</b>	Brushed Stainless Steel Drip Stand and Weighted Base, 4 Chrome Hooks, Anti-Static Castors

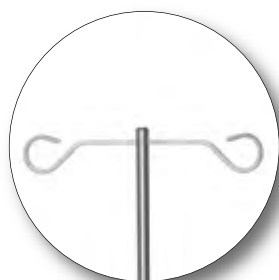

SUN-IV08 (SHOWN)

**Sun-IV08 & Sun-IV09**  
156cm - 267cm(H)  
58cm(W)



## IV Pole with Castors

- Bottle holder stainless steel  
4 hooks – 2 kg/hook
- **Tube diameter:** 25/18mm
- **Height adjustment:** screw adjustment
- **Regulating range:** 1.500mm–2.500mm
- **Outer tube length:** 1.200mm
- **Base diameter:** 680mm
- **Profile size (base arms):** 45 x 25mm
- **Casters:** Mono 80mm  
(2 x antistatic & lockable, 3 x normal)
- **Total Weight:**  
4.7kg (Standard)  
8.6kg (Weighted Base)



**HCF475** IV Pole on Castors

**HCF475.1** IV Pole on Castors with weighted base

## Steel Drip Stands

- Bottle holder stainless steel  
4 hooks – 2 kg/hook
- **Tube diameter:** 25/18mm
- **Height adjustment:** screw adjustment
- **Regulating range:** 1.350mm–2.150mm
- **Outer tube length:** 1.000mm
- **Base diameter:** 635mm
- **Base weight:** 1.9 kg (approx)
- **Profile size (base arms):** 25 x 25mm
- **Casters:** Twin 50 mm plastic casters  
(2x antistatic & lockable, 3x normal)
- **Total weight:** 3.9 kg (approx)



**HCF302** Mild Steel Drip Stand

**HCF303** Stainless Steel Drip Stand

## Silver Hygiene Centre

This unique and novel hygiene centre has been designed to help reduce the risk of hospital based cross infection between departments, patients, visitors and health care workers.

- Manufactured from stainless steel, the hygienic centre is portable and easy to clean with Amocid, Baktolan, Sagrotan
- Major components can be colour coded for organisation

### Provita Hygiene Stand includes:

- 2 Glove box holder
- 500cc disinfectant dispenser
- Drip bowl 2 Litre
- Wire mesh utensils basket
- Wire mesh baskets
- Mobile stand



**HCF813** Silver Finish Hygiene Centre

## Baby Assure Neonatal Cot

Our high-grade, portable care cot is designed for neonatal care environments. A safe, secure and comfortable platform.

### Structure

- Epoxy-coated steel tube frame.
- Gas strut height adjustment with manual lever under cradle.
- Removable cradle allowing for ease of cleaning and transfer.

### Comfort

- Includes polyurethane mattress with cover.
- 100% usable patient surface

### Ease Of Handling

- Four 65 mm swivelling castors for ease of manoeuvrability, two brake castors and two freewheeling castors.
- Hydraulic Trendelenburg / reverse Trendelenburg position up to  $\pm 13^\circ$ . Easy to adjust with manual lever.
- Hydraulic height adjustment, 640–940 mm.

### Safety

- Conforms to Regulation (EU) 2017/745

**HCF206** Medi-Plinth Baby Assure Care Cot

**HCF206.1** Baby Assure IV Pole

**HCF206.2** Baby Assure PU Mattress with Cover

### Specifications

- Height adjustment: 64–94cm
- Cradle dimensions: 65 x 36 x 22–29cm
- Overall dimensions: 92 x 57 x 102cm
- Trendelenburg / Reverse:  $\pm 13^\circ$
- Safe working load: 15kg
- Weight w/o accessories: 21kg

Medi **Plinth**



## Inspiration Cot

Designed in conjunction with the leading UK paediatric specialists, this cot is established as top for many UK paediatric hospital units; including Great Ormond Street Hospital in London.

- Variable height, electrically operated, two-way tilting mattress platform
- Removable head and foot ends allow 360° access when the side rails are down
- Uniquely designed drop down side rails
- Dual sided, linked, tracking and braking system for safety
- Up to two removable transfusion poles can be fitted (one placement option shown in image)
- Includes specially designed visco elastic mattress
- Buffers on all four corners and a shelf for linen
- 3 year warranty: (1 year parts & labour, 2/3 year parts only)
- **Dimensions (LxW):** 145 x 82cm
- **Adjustable Height:** 58.5–92cm
- **Max user weight:** 140kg / 22st, 45kg in Tilt
- **Safe Working Load:** 160kg (25st), 50kg in Tilt



**HCF1023** Inspiration Cot c/w VE Mattress, CPR and Hinged Access

## Lullaby Pro Drop Side Crib

This crib is designed specifically for rooming-in or co-sleeping to help develop that special mother and child bond, the crib can also be wheeled either side of the mother's bed for ease.

The Lullaby Pro meets the needs of the baby, parent and healthcare professional. The newborn is able to move around in the crib safely and the ventilation holes at the bottom of the crib provide extra reassurance that the baby is safe.

The Crib has a polyethylene structure and vertically lowering padded safety sides in transparent Plexiglas which is non-toxic, unbreakable and removable for cleaning.

**Dimensions:** 94 x 88 x 47–70cm



**HCF1535** Lullaby Pro Drop Side Crib

**HCF1536** Lullaby Pro – Lower Basket

**HCF1024** Lullaby VE Foam Mattress

## Shuttleworth Ward Screens

The Shuttleworth Medical mobile ward screen range is an ideal solution for permanent or temporary privacy. This ward screen is heavily used within the NHS for COVID-19 vaccine centres across the country.

Designed using high quality, durable and easy to clean materials for excellent infection control, it is perfect in a hospital or healthcare environment.

This ward screen is available in 3 sizes, 3 Panel, 4 Panel & 5 Panel. It is also available in solid white screen panels or with disposable, easy to attach & remove curtains.

- Designed & manufactured with the highest quality materials
- Corrosive resistant materials
- Epoxy coated white frame
- Hygienic, easy to clean design PVC panels
- A strong, sturdy leg structure together with swivel castors for ease of movement
- A clever, fold up, space saving design for storage
- The panels & curtains can be very easily removed or replaced if required
- These products have been used heavily in the NHS COVID-19 vaccine centres
- Available in three sizes: 3 Panel, 4 Panel & 5 Panel
- Available with Solid Panels or Disposable Curtains
- Supplied fully assembled

Shuttleworth



Made in the UK Since 1953



**HCF1846** 3 Panel Ward Screen – Solid Panels, White

**HCF1847** 3 Panel Ward Screen – Disposable Curtains

**HCF1848** 4 Panel Ward Screen – Solid Panels, White

**HCF1849** 4 Panel Ward Screen – Disposable Curtains

**HCF1850** 5 Panel Ward Screen – Solid Panels, White

**HCF1851** 5 Panel Ward Screen – Disposable Curtains

## Doherty Wards Screens

- Durable chrome or epoxy coated white frames
- Folds flat for storage
- Minimal assembly is required
- 65mm twin wheeled swivel castors for ease of manoeuvrability
- **Dimensions:** 168 x 244cm at maximum size



Plastic Colours:



Polyester Colours:



**HCF215** Doherty Ward Screen Epoxy – Frame Only

**HCF217** Plastic Curtains White – 4pk

**HCF218** Plastic Curtains Green – 4pk

**HCF389** Polyester Curtains Beige – 4pk

**HCF390** Polyester Curtains Blue – 4pk

## Doherty Panel Screen Kit

Designed to provide a modern alternative to the traditional plastic and polyester screen curtains. The system is available to fit to new Doherty white epoxy coated or chrome screens and can also be fitted to existing screens.

- Easy to clean hygienic construction with high specification fire retardant plastic panels
- Simple to fit to new or existing Doherty screens
- Panels cover full frame of screen for complete privacy
- 4 panels per kit supplied with all fittings & instructions
- **Screen Kit does not include frame**



Colour Choices:



**HCF215** Doherty Ward Screen Epoxy – Frame Only

**HCF534** Panel Screen Kit White

**HCF535** Panel Screen Kit – Select Colour

## Sunflower Mobile Privacy Screens Solid Panels



The Sunflower Medical mobile folding hospital ward screens with one piece disposable curtain are available in 3, 4 and 5 sections with 3 curtain colours. Disposable curtains are an effective tool in the fight against healthcare environment acquired infections. The disposable curtains have been designed to help control infection by making them both economical and easy to change more frequently. The curtains are manufactured from a durable, disposable and completely recyclable polypropylene fabric, resulting in low environmental impact.

- Available in 3, 4 and 5 sections
- Choice of 3 curtain colours
- Cost effective disposable curtain system
- Unique design
- No laundry costs
- Curtain labelling system for monitoring change dates
- One piece pleated curtain - easy to fit or replace
- Flame retardant curtains BS5867 part 2 type C
- Infection control friendly
- Recyclable polypropylene material
- Multiple leg supports for stability
- Durable epoxy coated white frame
- Swivel castors for ease of movement
- Folds flat for storage
- Easy clean design and materials
- Minimal assembly Required
- Environmentally Friendly
- Designed in partnership with Marlux Medical
- **NEW** 5 year warranty



<b>SUN-MFS3-DCPB</b>	Three Section Screen/Disposable Curtain - Pastel Blue
<b>SUN-MFS3-DCFG</b>	Three Section Screen/Disposable Curtain - Forest Green
<b>SUN-MFS3-DCSB</b>	Three Section Screen/Disposable Curtain - Summer Blue
<b>SUN-CUR3-DCPB</b>	Three Section Replacement Curtain - Pastel Blue
<b>SUN-CUR3-DCFG</b>	Three Section Replacement Curtain - Forest Green
<b>SUN-CUR3-DCSB</b>	Three Section Replacement Curtain - Summer Blue

<b>SUN-MFS4-DCPB</b>	Four Section Screen/Disposable Curtain - Pastel Blue
<b>SUN-MFS4-DCFG</b>	Four Section Screen/Disposable Curtain - Forest Green
<b>SUN-MFS4-DCSB</b>	Four Section Screen/Disposable Curtain - Summer Blue
<b>SUN-CUR4-DCPB</b>	Four Section Replacement Curtain - Pastel Blue
<b>SUN-CUR4-DCFG</b>	Four Section Replacement Curtain - Forest Green
<b>SUN-CUR4-DCSB</b>	Four Section Replacement Curtain - Summer Blue

<b>SUN-MFS5-DCPB</b>	Five Section Screen/Disposable Curtain - Pastel Blue
<b>SUN-MFS5-DCFG</b>	Five Section Screen/Disposable Curtain - Forest Green
<b>SUN-MFS5-DCSB</b>	Five Section Screen/Disposable Curtain - Summer Blue
<b>SUN-CUR5-DCPB</b>	Five Section Replacement Curtain - Pastel Blue
<b>SUN-CUR5-DCFG</b>	Five Section Replacement Curtain - Forest Green
<b>SUN-CUR5-DCSB</b>	Five Section Replacement Curtain - Summer Blue

curtain colours please specify when ordering

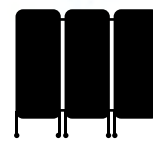

**3 Panel**  
172cm(H) 188cm(W) 3cm(D)  
38cm(D) Across Legs

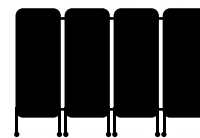

**4 Panel**  
172cm(H) 250cm(W) 3cm(D)  
38cm(D) Across Legs



**5 Panel**  
172cm(H) 312cm(W) 3cm(D)  
38cm(D) Across Legs

## Sunflower Mobile Privacy Screens Solid Panels

Designed to provide a temporary or permanent privacy solution. They are ideal for use as a hospital bed screen or as a general privacy screen. They are hygienically designed using our durable and easy to clean proven panel system, which is available in eight patterns and colours, including our NEW Jungle Design, which are ideal for children's wards or just as a fun addition to your surgery.

- Available in 3, 4 and 5 panel sizes
- Unique range of 8 patterns and colours
- Hygienic PVC panel system
- Multiple leg supports for stability
- Panels can be removed or replaced
- Flame retardant panels - BS476 part 7
- Swivel castors for ease of movement
- Durable epoxy coated white frame
- Folds flat for storage
- Easy clean design and materials
- Minimal assembly required
- **NEW** 5 year warranty

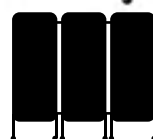

**3 Panel**  
172cm(H) 188cm(W) 3cm(D)  
38cm(D) Across Legs

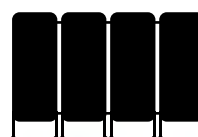

**4 Panel**  
172cm(H) 250cm(W) 3cm(D)  
38cm(D) Across Legs

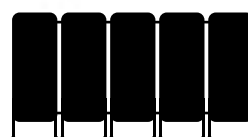

**5 Panel**  
172cm(H) 312cm(W) 3cm(D)  
38cm(D) Across Legs

<b>SUN-MFS3W</b>	Three Panel Screen - White
<b>SUN-MFS3BEI</b>	Three Panel Screen - Beige
<b>SUN-MFS3SIL</b>	Three Panel Screen - Silver
<b>SUN-MFS3SKY</b>	Three Panel Screen - Sky Blue
<b>SUN-MFS3PB</b>	Three Panel Screen - Blue Patchwork
<b>SUN-MFS3BUB</b>	Three Panel Screen - Bubble Design
<b>SUN-MFS3WAVE</b>	Three Panel Screen - Wave Design
<b>SUN-MFS3JUNGLE</b>	Three Panel Screen - Jungle Design
<b>SUN-MFS4W</b>	Four Panel Screen - White
<b>SUN-MFS4BEI</b>	Four Panel Screen - Beige
<b>SUN-MFS4SIL</b>	Four Panel Screen - Silver
<b>SUN-MFS4SKY</b>	Four Panel Screen - Sky Blue
<b>SUN-MFS4PB</b>	Four Panel Screen - Blue Patchwork
<b>SUN-MFS4BUB</b>	Four Panel Screen - Bubble Design
<b>SUN-MFS4WAVE</b>	Four Panel Screen - Wave Design
<b>SUN-MFS4JUNGLE</b>	Four Panel Screen - Jungle Design
<b>SUN-MFS5W</b>	Five Panel Screen - White
<b>SUN-MFS5BEI</b>	Five Panel Screen - Beige
<b>SUN-MFS5SIL</b>	Five Panel Screen - Silver
<b>SUN-MFS5SKY</b>	Five Panel Screen - Sky Blue
<b>SUN-MFS5PB</b>	Five Panel Screen - Blue Patchwork
<b>SUN-MFS5BUB</b>	Five Panel Screen - Bubble Design
<b>SUN-MFS5WAVE</b>	Five Panel Screen - Wave Design
<b>SUN-MFS5JUNGLE</b>	Five Panel Screen - Jungle Design

### screen panel patterns and colours

please specify when ordering

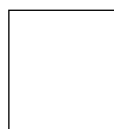

white



beige



silver



sky blue



blue patchwork



bubble design



wave design



jungle design



# MARLUX MEDICAL

## 100% Recyclable Privacy Curtains

## Supporting a Sustainable Future



We're committed to help form a **Greener** NHS



## Full Recycling Service

for a circular economy



## UK Manufacturing

to reduce our carbon footprint

## With Advanced Technology



Built-in Antimicrobial technology

## Prevents Bacterial Growth

on the surface of the curtain by up to 99.9999%



## Digital Curtain Management Solution

to save time and improve patient safety



Partnered with



We are dedicated to reducing our environmental impact by recycling or converting all our business waste into energy



### Marlux Medical Adapt-A-Track

Converting your existing curtain track couldn't be easier with the Marlux Medical Adapt-A-track.

By removing the current gliders from your existing system, it allows you to install Marlux Medical's Adapt-A-Track and our Fast-Fit Curtains. Saving you time and money when changing privacy curtains.

Adapt-A-Track is available in 18 metre coils.

HCF1143 MK4 Adapt-A-Track - 18 metres

HCF1143.1 MK5 Adapt-A-Track - 18 metres



## Marlux Medical 100% Recyclable Privacy Curtains

Marlux Medical curtains are 100% recyclable and are enhanced with Microban® antimicrobial technology which works continuously to eliminate up to 99.9999% of harmful bacteria on the surface of the curtain. Our curtains offer invisible protection to patients and continuously work against bacteria for the lifetime of the curtain.

Our privacy curtains are manufactured in the UK, allowing us to be flexible to your needs. We offer three different hook types to suit most hospital tracks, and our Fast-Fit Curtains can be fitted in under 3 minutes saving you hours each year. Our curtain widths are: 7.2m, 4.2m and 1.8m, with a standard drop of 1.95m.

We also offer custom print curtains, allowing you to tailor curtains to suit your need, colour, and design. Contact us for further information

Marlux Medical is constantly looking at ways to enhance our curtains to maintain a high standard of quality, and safety. All our curtains are fire retardant to improve safety.

To reduce waste and support the reduction in single use plastics, we offer a recycling service to our customers to collect and recycle any Marlux Medical curtains. Along with this, we've changed all our packaging to be eco-friendly and fully recyclable.

Marlux Medical is dedicated to reducing our overall environmental impact. Therefore, all our business waste is recycled or turned into energy. As a result, we're BSI certified ISO 14001.

### Recycling Service – Quotes Available On Request

Geographical charge may apply

**HCF1143.2** Marlux Curtain Recycle Service

### 4.2m Curtain Width

<b>HCF1145</b>	4.2m - Summer Blue - Fast Fit Hooking
<b>HCF1145.1</b>	4.2m - Summer Blue - Uni-Glide Hooking
<b>HCF1145.2</b>	4.2m - Summer Blue - Universal Hooking
<b>HCF1145.3</b>	4.2m - Pastel Blue - Fast Fit Hooking
<b>HCF1145.4</b>	4.2m - Pastel Blue - Uni-Glide Hooking
<b>HCF1145.5</b>	4.2m - Pastel Blue - Universal Hooking
<b>HCF1145.6</b>	4.2m - Bali Sand - Fast Fit Hooking
<b>HCF1145.7</b>	4.2m - Bali Sand - Uni-Glide Hooking
<b>HCF1145.8</b>	4.2m - Bali Sand - Universal Hooking
<b>HCF1145.9</b>	4.2m - Forest Green - Fast Fit Hooking
<b>HCF1145.10</b>	4.2m - Forest Green - Uni-Glide Hooking
<b>HCF1145.11</b>	4.2m - Forest Green - Universal Hooking
<b>HCF1145.12</b>	4.2m - Hospital Blue - Fast Fit Hooking
<b>HCF1145.13</b>	4.2m - Hospital Blue - Uni-Glide Hooking
<b>HCF1145.14</b>	4.2m - Hospital Blue - Universal Hooking
<b>HCF1145.15</b>	4.2m - Royal Lilac - Fast Fit Hooking
<b>HCF1145.16</b>	4.2m - Royal Lilac - Uni-Glide Hooking
<b>HCF1145.17</b>	4.2m - Royal Lilac - Universal Hooking
<b>HCF1145.18</b>	4.2m - Dove Grey - Fast Fit Hooking
<b>HCF1145.19</b>	4.2m - Dove Grey - Uni-Glide Hooking
<b>HCF1145.20</b>	4.2m - Dove Grey - Universal Hooking



### 1.8m Curtain Width

<b>HCF1144</b>	1.8m - Summer Blue - Fast Fit Hooking
<b>HCF1144.1</b>	1.8m - Summer Blue - Uni-Glide Hooking
<b>HCF1144.2</b>	1.8m - Summer Blue - Universal Hooking
<b>HCF1144.3</b>	1.8m - Pastel Blue - Fast Fit Hooking
<b>HCF1144.4</b>	1.8m - Pastel Blue - Uni-Glide Hooking
<b>HCF1144.5</b>	1.8m - Pastel Blue - Universal Hooking
<b>HCF1144.6</b>	1.8m - Bali Sand - Fast Fit Hooking
<b>HCF1144.7</b>	1.8m - Bali Sand - Uni-Glide Hooking
<b>HCF1144.8</b>	1.8m - Bali Sand - Universal Hooking
<b>HCF1144.9</b>	1.8m - Forest Green - Fast Fit Hooking
<b>HCF1144.10</b>	1.8m - Forest Green - Uni-Glide Hooking
<b>HCF1144.11</b>	1.8m - Forest Green - Universal Hooking
<b>HCF1144.12</b>	1.8m - Hospital Blue - Fast Fit Hooking
<b>HCF1144.13</b>	1.8m - Hospital Blue - Uni-Glide Hooking
<b>HCF1144.14</b>	1.8m - Hospital Blue - Universal Hooking
<b>HCF1144.15</b>	1.8m - Royal Lilac - Fast Fit Hooking
<b>HCF1144.16</b>	1.8m - Royal Lilac - Uni-Glide Hooking
<b>HCF1144.17</b>	1.8m - Royal Lilac - Universal Hooking
<b>HCF1144.18</b>	1.8m - Dove Grey - Fast Fit Hooking
<b>HCF1144.19</b>	1.8m - Dove Grey - Uni-Glide Hooking
<b>HCF1144.20</b>	1.8m - Dove Grey - Universal Hooking

### 7.2m Curtain Width

<b>HCF1146</b>	7.2m - Summer Blue - Fast Fit Hooking
<b>HCF1146.1</b>	7.2m - Summer Blue - Uni-Glide Hooking
<b>HCF1146.2</b>	7.2m - Summer Blue - Universal Hooking
<b>HCF1146.3</b>	7.2m - Pastel Blue - Fast Fit Hooking
<b>HCF1146.4</b>	7.2m - Pastel Blue - Uni-Glide Hooking
<b>HCF1146.5</b>	7.2m - Pastel Blue - Universal Hooking
<b>HCF1146.6</b>	7.2m - Bali Sand - Fast Fit Hooking
<b>HCF1146.7</b>	7.2m - Bali Sand - Uni-Glide Hooking
<b>HCF1146.8</b>	7.2m - Bali Sand - Universal Hooking
<b>HCF1146.9</b>	7.2m - Forest Green - Fast Fit Hooking
<b>HCF1146.10</b>	7.2m - Forest Green - Uni-Glide Hooking
<b>HCF1146.11</b>	7.2m - Forest Green - Universal Hooking
<b>HCF1146.12</b>	7.2m - Hospital Blue - Fast Fit Hooking
<b>HCF1146.13</b>	7.2m - Hospital Blue - Uni-Glide Hooking
<b>HCF1146.14</b>	7.2m - Hospital Blue - Universal Hooking
<b>HCF1146.15</b>	7.2m - Royal Lilac - Fast Fit Hooking
<b>HCF1146.16</b>	7.2m - Royal Lilac - Uni-Glide Hooking
<b>HCF1146.17</b>	7.2m - Royal Lilac - Universal Hooking
<b>HCF1146.18</b>	7.2m - Dove Grey - Fast Fit Hooking
<b>HCF1146.19</b>	7.2m - Dove Grey - Uni-Glide Hooking
<b>HCF1146.20</b>	7.2m - Dove Grey - Universal Hooking

## Medi-Beam Seating

Medi-Plinth's new modular range of waiting room/communal area seating, offers flexible seating solutions and a perfect balance of technology, functionality and design. All Medi-beam seatings includes a **1 Year Manufacturer Warranty**.

The Medi-beam seating is available in various configurations; from single chairs through to four seater benches. Upholstered seating is available in Medi-plinth's full range of 25 vinyl colours to suit any colour scheme. Their professional build quality and style ensure allow them to be suited to any environment.

**Medi Plinth**



### Medi-Beam Upholstered Seating

#### Upholstered Chair Features:

- 1 Year Manufacturer Warranty
- Maximum load per seat: 18 stone/114kgs
- 25 Standard vinyl colours
- Durable black epoxy coated mild steel frame
- Can be fixed or free standing
- Non-marking plastic feet
- Available with or without armrests

### Medi-Beam Wooden Seating

#### Upholstered Chair Features:

- 1 Year Manufacturer Warranty
- Maximum load per seat: 18 stone/114kgs
- Highly durable beech, lacquered plywood seat and back
- Durable black epoxy coated mild steel frame
- Can be fixed or free standing
- Non-marking plastic feet
- Available with or without armrests

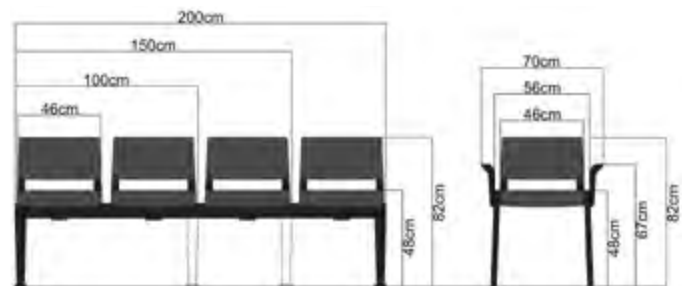
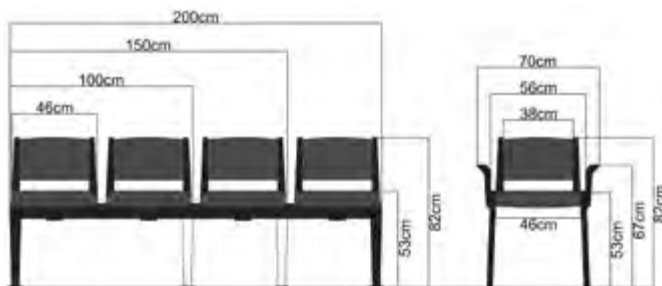

**CHRU01A** Upholstered Single Chair with Arms

**CHRU01** Upholstered Single Chair

**CHRW01A** Wooden Single Chair with Arms

**CHRW01** Wooden Single Chair

**BEAMU02A** Upholstered 2 Seat Beam with Arms

**BEAMU02** Upholstered 2 Seat Beam

**BEAMW02A** Wooden 2 Seat Beam with Arms

**BEAMW02** Wooden 2 Seat Beam

**BEAMU03A** Upholstered 3 Seat Beam with Arms

**BEAMU03** Upholstered 3 Seat Beam

**BEAMW03A** Wooden 3 Seat Beam with Arms

**BEAMW03** Wooden 3 Seat Beam

**BEAMU04A** Upholstered 4 Seat Beam with Arms

**BEAMU04** Upholstered 4 Seat Beam

**BEAMW04A** Wooden 4 Seat Beam with Arms

**BEAMW04** Wooden 4 Seat Beam



## Sunflower Venus Visitor Modular Seating Range

The Sunflower Medical contemporary range of modular hygienic patient, visitor and waiting room seating is designed for everyday use in health centres, clinics, hospitals, veterinary practices, doctors surgeries and other healthcare environments.



**5 Seat Module**  
78cm(H) 253cm(W) 66cm(D)



**4 Seat Module**  
78cm(H) 203cm(W) 66cm(D)



**4 Seat Module**  
78cm(H) 153cm(W) 66cm(D)

- 110kg Maximum user weight (17st.) per seat
- Durable moulded polypropylene seats
- Comfortable deep foam upholstered seats
- Rounded/upholstered seat corners
- Anti-bacterial Vinyl Upholstery
- Anti-bacterial Vinyl - Fire (Flammability) Testing BS 7176 Medium Hazard BS 5852 : 2006 Clause 11
- Adjustable feet for uneven floors
- Durable silver epoxy coated frame
- Magazine table option
- Minimal assembly required (tools supplied)
- Optional installation service available
- Easy clean design and materials
- **NEW** 5 year warranty

**SUN-SEAT3** Venus Visitor 3 Seat Module - 3 Moulded Seats

**SUN-SEAT3VYL** Venus Visitor 3 Seat Module - Anti-bacterial Vinyl

**SUN-SEAT4** Venus Visitor 4 Seat Module - 3 Moulded Seats

**SUN-SEAT4VYL** Venus Visitor 4 Seat Module - Anti-bacterial Vinyl

**SUN-SEAT4T** Venus Visitor 3 Seat 1 Table Module - 3 Moulded Seats

**SUN-SEAT4TVYL** Venus Visitor 3 Seat 1 Table Module - Anti-bacterial Vinyl

**polypropylene seats** please specify when ordering



black blue grey beige

**anti-bacterial vinyl upholstery colours**

please specify when ordering



black grey beige primrose red wine lilac navy mid blue



sky blue cool blue green mint white

**SUN-SEAT5** Venus Visitor 5 Seat Module - 3 Moulded Seats

**SUN-SEAT5VYL** Venus Visitor 5 Seat Module - Anti-bacterial Vinyl

**SUN-SEAT5T** Venus Visitor 4 Seat 1 Table Module - 3 Moulded Seats

**SUN-SEAT5TVYL** Venus Visitor 4 Seat 1 Table Module - Anti-bacterial Vinyl

## Wooden Waiting Room Furniture

A comprehensive solution to your healthcare waiting room requirements. The use of our easy-clean and durable upholstery make it ideal for most surgery, clinic or physio practices.

Our open back wooden waiting room chairs include arm rests and are available in the full range of 14 upholstery colours. This modular, durable wooden furniture provides both comfortable and colourful seating options for any reception/waiting areas.

### Select your choice of regular or bariatric width chair.

- Chair seat height: 45.5cm
- Total height of chair: 86cm
- Width of chair: 58cm / 84cm (Bariatric)
- Chair depth: 57cm
- Max load capacity: 114kg
- **Please specify upholstery colour when ordering**

<b>WWS1</b>	Wooden Waiting Room Chair
<b>WWS1A</b>	Wooden Waiting Room Chair with Arms
<b>BWWS1A</b>	Bariatric Wooden Waiting Room Chair with Arms



**Medi Plinth**

Made in the UK  
 2 Year Warranty

## Cassius Waiting Room Chairs

Designed to be easy to clean, robust and colourful. The use of our easy-clean and durable upholstery make it ideal for most settings. The chair is manufactured with a special strengthening bar that also allows vertical stacking up to 10 high.

Each chair comes with four hard wearing plastic feet to prevent marking. These feet are also shaped to prevent the chair frames rubbing when stacked. The arms for the chair are securely bolted into place and a linking system is also available as an option for the armed version. The Cassius arms are hard wearing and robust in matching black plastic.

- 120kg maximum user capacity
- Easy to clean with standard NHS cleaning solutions.
- Standard strengthening bar
- Vertical safe stacking up to 10 to save space when storing
- Standard built in linking system for side chair version
- Dimensions: 81cm x 55cm x 52.5cm  
Seat 47 x 46cm
- **Please specify upholstery colour when ordering**

<b>HCF1675</b>	Cassius Waiting Chair without Arms (Specify Colour)
<b>HCF1684</b>	Cassius Waiting Chair with Arms (Specify Colour)
<b>HCF1674</b>	Cassius Chair Link (Join 2 Cassius Chairs with Arms)



**Medi Plinth**

Made in the UK  
 2 Year Warranty

### MRSA resistant anti bacterial & fire retardant vinyl colours:

Pillar Box Red	Raspberry Crush	Candy	Damson	Dark Blue	Mid Blue	Sky Blue
Apple Mint	Citrus Green	Dune	Ash Grey	Gun Metal Grey	Black	White

## Rollo Waiting Room Chairs

With a range of 4 contemporary colours for the seat and back, combined with a stylish black hard-wearing frame, this really is an ideal budget waiting room chair.

Manufactured with a strengthening bar that allows vertical stacking up to 10 high. This bar also acts as a built-in link to allow the chairs to link together as standard (chairs without arms).

- 120kg maximum user capacity
- Easy to clean with standard NHS cleaning solutions.
- Standard strengthening bar
- Vertical safe stacking up to 10 to save space when storing
- Standard built in linking system for side chair version
- Dimensions: 81cm x 55cm x 52.5cm  
Seat: 46 x 46cm
- **Please specify upholstery colour when ordering**

<b>HCF1666</b>	Black Moulded Plastic Seat & Back without Arms
<b>HCF1667</b>	Navy Moulded Plastic Seat & Back without Arms
<b>HCF1668</b>	Mid Blue Moulded Plastic Seat & Back without Arms
<b>HCF1669</b>	Dark Grey Moulded Plastic Seat & Back without Arms
<b>HCF1670</b>	Black Moulded Plastic Seat & Back with Arms
<b>HCF1671</b>	Navy Moulded Plastic Seat & Back with Arms
<b>HCF1672</b>	Mid Blue Moulded Plastic Seat & Back with Arms
<b>HCF1673</b>	Dark Grey Moulded Plastic Seat & Back with Arms
<b>HCF1670.1</b>	Rollo Chair Link (Join 2 Rollo Chairs with Arms)



**Medi Plinth**

Made in the UK

2 Year Warranty

B

Furniture

## Sunflower Visitor and Patient Chairs

Contemporary range of chairs, which are durable, hygienic and easy to clean, designed for waiting, reception and public areas. Available in a wide range of colours and anti-bacterial fabrics.

- 110kg Maximum user weight (17st.) per seat
- Durable moulded polypropylene seats
- Plastic feet prevent movement and protect floors
- Safe and easy to stack (max. 10 high)
- Supplied fully assembled and moulded seats
- Easy clean design and materials
- Chair linking kits available
- **NEW 5 year warranty**

save when buying quantities of **10+**  
PLEASE ENQUIRE



sunflower  
HEALTHCARE FURNITURE



Sun-SEAT1



79cm(H)  
54cm(W)  
56cm(D)  
Seat Height  
44cm(H)



<b>SUN-SEAT1-BLACK</b>	Venus Visitor Chair - Black
<b>SUN-SEAT1-BLUE</b>	Venus Visitor Chair - Blue
<b>SUN-SEAT1-GREY</b>	Venus Visitor Chair - Grey
<b>SUN-SEAT1-BEIGE</b>	Venus Visitor Chair - Beige
<b>SUN-SEAT-LINK1</b>	Chair Linking Kit (for chairs with no arms)
<b>SUN-SEAT2-BLACK</b>	Venus Visitor Chair with Arms - Black
<b>SUN-SEAT2-BLUE</b>	Venus Visitor Chair with Arms - Blue
<b>SUN-SEAT2-GREY</b>	Venus Visitor Chair with Arms - Grey
<b>SUN-SEAT2-BEIGE</b>	Venus Visitor Chair with Arms - Beige
<b>SUN-SEAT-LINK2</b>	Chair Linking Kit (for chairs with arms)



Sun-SEAT/LINK1 Sun-SEAT/LINK2



Sun-SEAT2

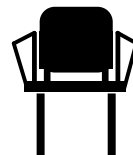

79cm(H)  
58cm(W)  
56cm(D)  
Seat Height  
44cm(H)

**moulded polypropylene** please specify when ordering



black blue grey beige

## Sunflower Visitor Seating Range

Contemporary, durable and hygienic range of visitor and patient seating designed for healthcare environments. Available in a wide range of colours in anti-bacterial vinyl.

### GALAXY CHAIRS

Multi-purpose upholstered economy seating offering quality design, comfort and ultimate function for waiting rooms, reception areas and public spaces.

- 110kg Maximum user weight (17st.) per seat
- Comfortable deep foam upholstery
- Rounded/upholstered seat corners
- Safe and easy to stack (max. 5 high)
- Plastic feet prevent movement/protect floors
- Anti-bacterial Vinyl Upholstery
- Anti-bacterial Vinyl - Fire (Flammability) Testing BS 7176 Medium Hazard BS 5852 : 2006 Clause 11
- Supplied fully assembled
- Easy clean design and materials
- Chair Linking Kit for Chairs with No Arms - Sun-SEAT/LINK1
- Chair Linking Kit for Chairs with Arms - Sun-SEAT/LINK2
- **NEW** 5 year warranty

Dimensions:

SEAT32 82cm(H) 54cm(W) 52cm(D) Seat Height 44cm(H)

SEAT33 82cm(H) 58cm(W) 52cm(D) Seat Height 44cm(H)

### AURORA CHAIRS

Deluxe solid beech upholstered seating, offering quality design, comfort and ultimate function for waiting rooms, reception areas and public spaces.

- 110kg Maximum user weight (17st.) per seat
- Comfortable deep foam upholstery
- Anti-bacterial Vinyl Upholstery
- Anti-bacterial Vinyl - Fire (Flammability) Testing BS 7176 Medium Hazard BS 5852 : 2006 Clause 11
- Solid lacquered beech wood frame
- Safe and easy to stack (max. 3 high)
- Supplied fully assembled
- Easy clean design and materials
- **NEW** 5 year warranty

Dimensions:

SEAT35 84cm(H) 51cm(W) 57cm(D) Seat Height 45cm(H)

SEAT36 84cm(H) 53cm(W) 57cm(D) Seat Height 45cm(H)

SEAT37 84cm(H) 56cm(W) 57cm(D) Seat Height 48cm(H)

### anti-bacterial vinyl upholstery colours

please specify when ordering



SUN-SEAT32



SUN-SEAT33



SUN-SEAT35



SUN-SEAT36



SUN-SEAT37



### AURORA EASY ACCESS CHAIR

The Aurora Easy Access Visitor Chair is a range extension to the existing and successful Aurora seating. With an extended squared arm rest to aid in the entry and exit from the chair seat. This is ideal for all users but particularly of use to older or less able visitors.

**SUN-SEAT32VYL** Galaxy Visitor Chair - Anti-bacterial Vinyl

**SUN-SEAT33VYL** Galaxy Visitor Chair with Arms - Anti-bacterial Vinyl

**SUN-SEAT35VYL** Aurora Visitor Chair - Anti-bacterial Vinyl

**SUN-SEAT36VYL** Aurora Visitor Chair with Arms - Anti-bacterial Vinyl

**SUN-SEAT37VYL** Aurora Visitor Easy Access Chair - Anti-bacterial Vinyl

## Sunflower Visitor and Patient Chairs

Contemporary, durable and hygienic range of visitor and patient seating designed for healthcare environments. Available in a wide range of colours in anti-bacterial vinyl.



B

Furniture

### GENESIS CHAIRS

The Genesis Easy Access Visitor Chair provides an extended squared arm rest to aid in the entry and exit from the chair seat. This is ideal for all users but particularly of use to older or less able visitors. This easy access feature is combined with an attractive, modern, slightly deeper, square section seat back. The chair is available as a side chair to compliment the arm chair.

- 110kg Maximum user weight (17st.) per seat
- Comfortable deep foam upholstery
- Anti-bacterial Vinyl Upholstery
- Anti-bacterial Vinyl - Fire (Flammability) Testing BS 7176 Medium Hazard BS 5852 : 2006 Clause 11
- Solid lacquered beech wood frame
- Safe and easy to stack (max. 3 high)
- Supplied fully assembled
- Easy clean design and materials
- **NEW** 5 year warranty

Dimensions:

SEAT41 86cm(H) 56cm(W) 57cm(D) Seat Height 48cm(H)

SEAT42 86cm(H) 56cm(W) 57cm(D) Seat Height 48cm(H)



### AURORA BARIATRIC CHAIR

Our 340kg (54st.) Aurora Bariatric arm chair offers strength, stability which is comfortable and easy to clean.

- Maximum User Weight 222kg (34st.)
- Comfortable deep foam upholstered seat and back
- Solid lacquered beech wood frame
- Anti-bacterial Vinyl upholstery
- Anti-bacterial Vinyl - Fire (Flammability) Testing BS 7176 Medium Hazard BS 5852 : 2006 Clause 11
- Available in 13 colours
- Supplied fully assembled
- Easy clean design and materials
- **NEW** 5 year warranty

Dimensions:

SEAT75 88cm(H) 84cm(W) 58cm(D)

Seat Width 72cm Seat Height 45cm



SUN-SEAT41



SUN-SEAT42



SUN-SEAT75

### anti-bacterial vinyl upholstery colours

please specify when ordering



**SUN-SEAT41VYL** Genesis Easy Access Chair - Anti-bacterial Vinyl

**SUN-SEAT42VYL** Genesis Easy Access Chair with Arms - Anti-bacterial Vinyl

**SUN-SEAT75VYL** Aurora 34st. Bariatric Chair - Anti-bacterial Vinyl

## Sunflower Phlebotomy Chairs

Durable, stable and ergonomically designed, phlebotomy chairs are easy to use and adjust and can be used left, right or dual sided with an additional arm, whilst also being easy to clean.

- Maximum user weight 110kg (17st.)
- Lightweight design only 8kgs
- Multi-position arm rest, made from a hygienic PU moulding
- Arm rest can be positioned either side (2 brackets supplied)
- Ergonomically designed moulded seat and back (Sun-PCHA only)
- Anti-bacterial/anti-microbial vinyl (Sun-PCHA-VYL only)
- Anti-bacterial Vinyl - Fire (Flammability) Testing BS 7176 Medium Hazard BS 5852 : 2006 Clause 11 (Sun-PCHA-VYL only)
- 40mm Deep foam for support and comfort (Sun-PCHA-VYL only)
- Independently tested by FIRA
- Supplied fully assembled
- Easy clean design and materials
- **NEW** 5 year warranty

**SUN-PCHA-BLACK** Phlebotomy-Treatment Chair - Black

**SUN-PCHA-BLUE** Phlebotomy-Treatment Chair - Blue

**SUN-PCHA-GREY** Phlebotomy-Treatment Chair - Grey

**SUN-PCHA-BEIGE** Phlebotomy-Treatment Chair - Beige

**SUN-PCHA-VYL** Phlebotomy-Treatment Chair - in Vinyl Upholstery

**SUN-PCHA-ARM** Additional Arm Rest



### moulded seat & back colours

please specify when ordering



### anti-bacterial vinyl upholstery colours

please specify when ordering



**SUN-PCHA-COLOUR**  
Phlebotomy-Treatment Chair



**SUN-PCHA-VYL**  
Phlebotomy-Treatment Chair  
in Vinyl Upholstery

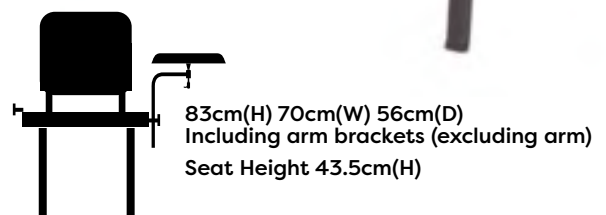

Maximum user weight 110kg (17st.)

## Sunflower Neptune Visitor Modular Seating Range

Neptune offers a contemporary range of seating modules and chairs, with great design and stability whilst being durable, hygienic and easy to clean. Available in 7 modern and vibrant colours with the option of an upholstered seat pad in anti-bacterial vinyl.



### 5 Seat Module

75cm(H) 250cm(W) 60cm(D)

### 4 Seat Module

75cm(H) 200cm(W) 60cm(D)

### 3 Seat Module

75cm(H) 150cm(W) 60cm(D)

Seat Height 42cm

- Maximum user weight 127kg (20st.) per seat
- One piece moulded polypropylene seats
- Comfortable foam upholstered seat pads
- Strong ergonomic chrome arms and legs
- Adjustable feet for uneven floors
- Choice of 7 moulded seat colours
- Choice of upholstered seat pads
- Vinyl Anti-bacterial Upholstery
- Anti-bacterial Vinyl - Fire (Flammability) Testing BS 7176 Medium Hazard BS 5852 : 2006 Clause 11
- Easy clean design and materials
- Minimal assembly required (tools supplied)
- Optional installation service available
- **NEW** 5 year warranty



### moulded seat colours

please specify when ordering



black grey blue green yellow orange ivory

### anti-bacterial vinyl seat pad upholstery colours

please specify when ordering

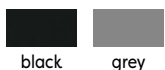

black grey

**SUN-SEAT73-3-COLOUR** Neptune Visitor 3 Seat Module - 3 Moulded Seats

**SUN-SEAT73-3-COLOUR-VYL-COLOUR** Neptune Visitor 3 Seat Module - 3 Moulded Seats  
3 Vinyl Upholstered Seat Pads

**SUN-SEAT74-4-COLOUR** Neptune Visitor 4 Seat Module - 4 Moulded Seats

**SUN-SEAT74-4-COLOUR-VYL-COLOUR** Neptune Visitor 4 Seat Module - 4 Moulded Seats  
4 Vinyl Upholstered Seat Pads

**SUN-SEAT75-5-COLOUR** Neptune Visitor 5 Seat Module - 5 Moulded Seats

**SUN-SEAT75-5-COLOUR-VYL-COLOUR** Neptune Visitor 5 Seat Module - 5 Moulded Seats  
5 Vinyl Upholstered Seat Pads

## Sunflower Atlas Bariatric High Back Arm Chair Range

Deluxe solid beech frame upholstered seating range with deep foam padded seat and back for optimum comfort. Optional drop arms to aid lateral transfer.

- Maximum User Weight 254kg (40st.)
- Comfortable deep foam upholstery
- Solid beech frame
- Solid beech arms
- Optional pressure relieving foam upgrade
- Drop arms to aid lateral transfer (Sun-CHA55DA & Sun-CHA56DA)
- Wings for head support (Sun-CHA56 only)
- Optional adjustable height legs (10cm extension)
- Optional housekeeping wheels available (fitted to rear legs only)
- Anti-bacterial Vinyl upholstery
- Anti-bacterial Vinyl - Fire (Flammability) Testing BS 7176 Medium Hazard BS 5852 : 2006 Clause 11
- Complies to (fire safety) regulations 1988 schedule 1 part 1
- Easy clean design and materials
- Supplied fully assembled
- **NEW** 5 year warranty



SUN-CHA55



SUN-CHA55DA



SUN-CHA56



**SUN-CHA55VYL** Atlas High Back 40st. Bariatric Arm Chair - Anti-bacterial Vinyl

**SUN-CHA55DAVYL** Atlas High Back 40st. Bariatric Arm Chair With Drop Arms - Anti-bacterial Vinyl

**SUN-CHA56VYL** Atlas High Back 40st. Bariatric Arm Chair With Wings - Anti-bacterial Vinyl

**SUN-CHA56DAVYL** Atlas High Back 40st. Bariatric Arm Chair With Wings and Drop Arms - Anti-bacterial Vinyl



**SUN-CHA55-PRF**  
£94.00  
Pressure Relieving Foam Upgrade for Seat and Back



**SUN-CHA56-PRF**  
£95.00  
Pressure Relieving Foam Upgrade for Seat and Back



**SUN-CHA50-AHL\***  
£172.00  
Adjustable Height Legs (10cm extension)



**SUN-CHA50-HKW\***  
£39.00  
House Keeping Wheels (fitted to rear legs only)

\*these accessories can only be fitted when ordered with the chair



Sun-CHA55

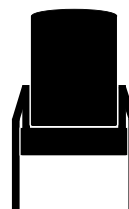

110cm(H)  
93cm(W)  
73cm(D)

Sun-CHA55DA



110cm(H)  
93cm(W)  
73cm(D)

Sun-CHA56

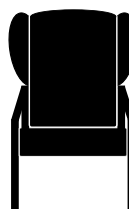

126cm(H)  
93cm(W)  
73cm(D)

Sun-CHA56DA



126cm(H)  
93cm(W)  
73cm(D)

Seat Heights 51cm - Internal Seat Widths 81cm

### anti-bacterial vinyl upholstery colours

please specify when ordering





# Sunflower Atlas Patient Arm Chair Range

Deluxe solid beech frame upholstered seating range with deep foam padded seat and back for optimum comfort.

- Maximum User Weight 110kg (17st.)
- Comfortable deep foam upholstery
- Sacral gap allows easy cleaning and access to fit hoist slings
- Solid beech frame
- Solid beech easy grip arms for ease of entry & exit
- Optional pressure relieving foam upgrade
- Optional drop-arms to aid lateral transfer (mid & high back chairs)
- Wings for head support (Sun-CHA52 only)
- Optional adjustable height legs (10cm extension)
- Optional housekeeping wheels available (fitted to rear legs only)
- Anti-bacterial Vinyl upholstery
- Anti-bacterial Vinyl - Fire (Flammability) Testing BS 7176 Medium Hazard BS 5852 : 2006 Clause 11
- Complies to (fire safety) regulations 1988 schedule 1 part 1
- Easy clean design and materials
- Supplied fully assembled
- **NEW** 5 year warranty

<b>SUN-CHA48VYL</b>	Atlas Patient Low-Back Side Chair - Anti-bacterial Vinyl
<b>SUN-CHA49VYL</b>	Atlas Patient Low-Back Arm Chair - Anti-bacterial Vinyl
<b>SUN-CHA50VYL</b>	Atlas Patient Mid-Back Arm Chair - Anti-bacterial Vinyl
<b>SUN-CHA50DAVYL</b>	Atlas Patient Mid-Back Arm Chair With Drop Arms - Anti-bacterial Vinyl



**SUN-CHA48-PRF**  
£50.00

Pressure Relieving Foam Upgrade for Seat and Back



**SUN-CHA49-PRF**  
£51.00

Pressure Relieving Foam Upgrade for Seat and Back



**SUN-CHA50-PRF**  
£52.00

Pressure Relieving Foam Upgrade for Seat and Back



**SUN-CHA50-AHL\***  
£172.00

Adjustable Height Legs (10cm extension)



**SUN-CHA50-HKW\***  
£39.00

House Keeping Wheels (fitted to rear legs only)

\* these accessories can only be fitted when ordered with the chair

## anti-bacterial vinyl upholstery colours

please specify when ordering



**SUN-CHA48**



**SUN-CHA49**



**SUN-CHA50**



**SUN-CHA50DA**

Sun-CHA48



94cm(H)  
54cm(W)  
63cm(D)

Sun-CHA49



94cm(H)  
60cm(W)  
60cm(D)

Sun-CHA50



104cm(H)  
60cm(W)  
60cm(D)

Sun-CHA50DA



104cm(H)  
60cm(W)  
60cm(D)

Seat Heights 48cm - Internal Seat Widths 49cm

## Sunflower Atlas Patient Arm Chair Range

Deluxe solid beech frame upholstered seating range with deep foam padded seat and back for optimum comfort.

- Maximum User Weight 110kg (17st.)
- Comfortable deep foam upholstery
- Sacral gap allows easy cleaning and access to fit hoist slings
- Solid beech frame
- Solid beech easy grip arms for ease of entry & exit
- Optional pressure relieving foam upgrade
- Optional drop-arms to aid lateral transfer (mid & high back chairs)
- Wings for head support (Sun-CHA52 only)
- Optional adjustable height legs (10cm extension)
- Optional housekeeping wheels available (fitted to rear legs only)
- Anti-bacterial Vinyl upholstery
- Anti-bacterial Vinyl - Fire (Flammability) Testing BS 7176 Medium Hazard BS 5852 : 2006 Clause 11
- Complies to (fire safety) regulations 1988 schedule 1 part 1
- Easy clean design and materials
- Supplied fully assembled
- **NEW** 5 year warranty



SUN-CHA51



SUN-CHA51DA



**SUN-CHA51VYL** Atlas Patient High-Back Arm Chair - Anti-bacterial Vinyl

**SUN-CHA51DAVYL** Atlas Patient High-Back Arm Chair With Drop Arms - Anti-bacterial Vinyl

**SUN-CHA52VYL** Atlas Patient High-Back Arm Chair With Wings - Anti-bacterial Vinyl

**SUN-CHA52DAVYL** Atlas Patient High-Back Arm Chair With Wings and Drop Arms - Anti-bacterial Vinyl



SUN-CHA52



**SUN-CHA51-PRF**  
£53.00

Pressure Relieving Foam Upgrade for Seat and Back



**SUN-CHA52-PRF**  
£54.00

Pressure Relieving Foam Upgrade for Seat and Back



**SUN-CHA50-AHL\***  
£172.00

Adjustable Height Legs (10cm extension)



**SUN-CHA50-HKW\***  
£39.00

House Keeping Wheels (fitted to rear legs only)

\*these accessories can only be fitted when ordered with the chair

Sun-CHA51



117cm(H)  
60cm(W)  
60cm(D)

Sun-CHA51DA



117cm(H)  
60cm(W)  
60cm(D)

Sun-CHA52

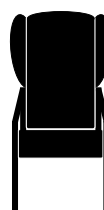

118cm(H)  
60cm(W)  
60cm(D)

Sun-CHA52DA



118cm(H)  
60cm(W)  
60cm(D)

### anti-bacterial vinyl upholstery colours

please specify when ordering



Seat Heights 48cm - Internal Seat Widths 49cm

## Sunflower Consultation Room Chairs

Premium range of fully adjustable consultation chairs, suitable for daily use in healthcare environments.

- Maximum user weight (20st.)
- Anti-bacterial Vinyl upholstery
- Anti-bacterial Vinyl - Fire (Flammability) Testing BS 7176 Medium Hazard BS 5852 : 2006 Clause 11
- Tested by FIRA to comply with BS EN 1335, 2&3: 2009
- Gas-lift seat height adjustment
- Adjustable height range (44-58)
- Mid or high back chairs available
- Twin levers adjust seat height & back angle
- Optional fixed arms
- Five star chrome base or Five star black nylon base
- Complies to (fire safety) regulations 1988 schedule 1 part 1
- Easy clean design and materials
- **NEW** 5 year warranty



SUN-CHA20-M



SUN-CHA20-MSA

### SOLITAIRE CHAIRS (MID BACK)

SUN-CHA20VYL-M	Consultation Chair - Anti-bacterial Vinyl
SUN-CHA20VYL-MS	Consultation Chair with Chrome Base - Anti-bacterial Vinyl
SUN-CHA20VYL-MA	Consultation Chair with Arms - Anti-bacterial Vinyl
SUN-CHA20VYL-MSA	Consultation Chair with Arms & Chrome Base - Anti-bacterial Vinyl

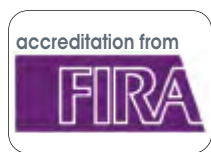

Tested by FIRA to comply with BS EN 1335, 2&3:2009



SUN-CHA21-M



SUN-CHA21-HA

### SOLITAIRE CHAIRS (HIGH BACK)

SUN-CHA21VYL-H	Consultation Chair - Anti-bacterial Vinyl
SUN-CHA21VYL-HS	Consultation Chair with Chrome Base - Anti-bacterial Vinyl
SUN-CHA21VYL-HA	Consultation Chair with Arms - Anti-bacterial Vinyl
SUN-CHA21VYL-HSA	Consultation Chair with Arms & Chrome Base - Anti-bacterial Vinyl

### anti-bacterial vinyl upholstery colours

please specify when ordering

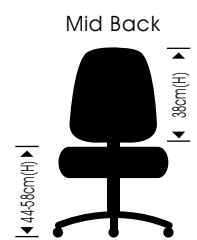

44 - 58cm(H)  
Seat Width 48cm  
Base 60cm Ø

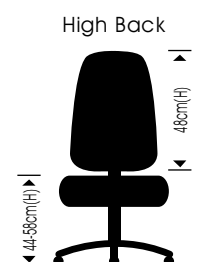

44 - 58cm(H)  
Seat Width 48cm  
Base 60cm Ø

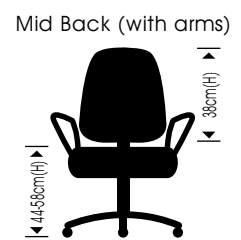

44 - 58cm(H)  
Seat Width 48cm  
Base 60cm Ø

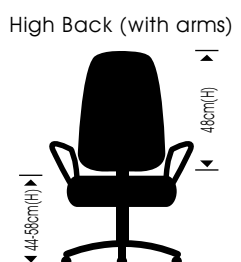

44 - 58cm(H)  
Seat Width 48cm  
Base 60cm Ø

## Sunflower Consultation Room Chairs

Premium range of fully adjustable consultation chairs, suitable for daily use in healthcare environments.

- Maximum user weight (20st.)
- Anti-bacterial Vinyl upholstery
- Anti-bacterial Vinyl - Fire (Flammability) Testing BS 7176 Medium Hazard BS 5852 : 2006 Clause 11
- Tested by FIRA to comply with BS EN 1335, 2&3:2009
- Gas-lift seat height adjustment
- Adjustable height range (44-58)
- Three levers adjust seat height, seat tilt and back angle
- Independent controlled seat slide
- Adjustable lumbar support (SUN-CHA23-EAALC only)
- Fixed or adjustable arms
- Five star chrome base
- Designed for 24 hour usage
- 5 year upholstery wearability warranty (inter/vene)
- Easy clean design and materials
- **NEW** 5 year warranty

**sunflower**  
HEALTHCARE FURNITURE



SUN-CHA23-EC



SUN-CHA230-EAC



SUN-CHA23-EAAC



SUN-CHA23-EAALC

### QUASAR DELUXE CHAIRS

- SUN-CHA23VYL-EC** Deluxe Consultation Chair - Anti-bacterial Vinyl
- SUN-CHA23VYL-EAC** Deluxe Consultation Chair with Fixed Arms - Anti-bacterial Vinyl
- SUN-CHA23VYL-EAAC** Deluxe Consultation Chairs with Adjustable Arms - Anti-bacterial Vinyl
- SUN-CHA23VYL-EAALC** Deluxe Consultation Chair with Adjustable Arms and Lumbar Support - Anti-bacterial Vinyl

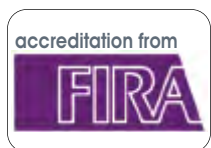

Tested by FIRA to comply with BS EN 1335, 2&3:2009



### anti-bacterial vinyl upholstery colours

please specify when ordering

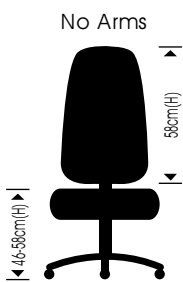

46 - 58cm(H)  
Seat Width 50cm  
Base 60cm ∅

Adjustable Arms

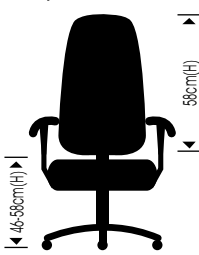

46 - 58cm(H)  
Seat Width 50cm  
Base 60cm ∅

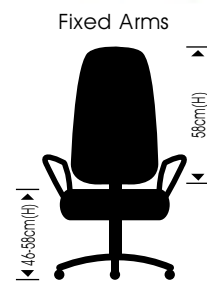

46 - 58cm(H)  
Seat Width 50cm  
Base 60cm ∅

Adjustable Arms & Lumbar

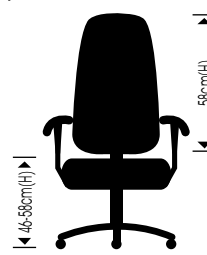

46 - 58cm(H)  
Seat Width 50cm  
Base 60cm ∅

## Magrini Vertical Baby Changer

- Perfect for areas where wall space is limited
- Unique hinge construction that eliminates finger traps, even on opening and closing
- The hinge rotates within the enclosed moulding eliminating exposure to moving parts
- Independently tested to static load in excess of 80kg (Decree 91-1292)
- Intended for use by babies up to 12 months, 11kg
- Extra-deep, all-around barriers eliminate the need for any safety straps
- **Dimensions:** 545 x 860 x 140 mm
- **Projection:** 830mm
- **Weight:** 11kg

**Please specify your colour choice when ordering:**

White fleck, or Oatmeal



**HCF195** Vertical Baby Changing Unit – Select Colour

**HCF801** Magrini Liner Dispenser

## Magrini Horizontal Baby Changer

- Contoured, contemporary design
- Unique hinge construction that eliminates finger traps, even on opening and closing
- Hinge rotates within the enclosed moulding eliminating exposure to moving parts
- Independently tested to static load in excess of 80kg (Decree 91-1292)
- Intended for use by babies up to 12 months, 11kg
- Extra-deep, all-around barriers eliminate the need for any safety straps
- **Dimensions:** 760 x 585 x 145 mm
- **Projection:** 540mm
- **Weight:** 11kg

**Please specify your colour choice when ordering:**

White fleck, or Oatmeal



**HCF194** Horizontal Baby Changing Unit – Select Colour

**HCF801** Magrini Liner Dispenser

## Magrini Countertop Baby Changer

- Provides a safe, durable baby changing facility in public washrooms where wall-mounted units are not practical
- Durable, solid moulding
- No surface fixing screws
- Hygienic finish with easy maintenance
- Extra deep barriers eliminate any need for straps reducing maintenance and inspection costs
- Easy-fit system for fast installation
- **Dimensions:** 780 x 560 x 165 mm
- **Weight:** 9.5kg

**Please specify your colour choice when ordering:**

White fleck, or Oatmeal



**HCF818** Countertop Baby Changing Unit – Select Colour

**HCF801** Magrini Liner Dispenser

## Magrini Steel Nappy Changer

This stainless steel wall mounted baby changing unit offers strength and durability. The all-metal construction is designed to withstand abuse and is ideal for unsupervised areas.

- Graffiti/vandal resistant, ideal for areas without CCTV
- Independently tested to EN12221
- Compact fold away design
- Exceptional fire resistance
- Withstands static loads of 75Kgs
- Intended for use by babies up to 12 months, 11kg
- **Dimensions:** 760 x 650 x 165 mm
- **Projection:** 615mm
- **Weight:** 17kg



**HCF747** Stainless Steel Nappy Changing Unit

**HCF801** Magrini Liner Dispenser

## Magrini Stay-Safe Baby Seat

Gives parents a place to seat their babies with them safely inside a changing cubicle, toilet or fitting room .

- Compact fold-away design
- Enclosed hinge eliminates finger traps
- Contoured seat with raised side barriers for intrinsic safety
- Integral 3-point strap incorporates adjustable waist and crotch restraints with snap-lock buckle
- Certified free from pesticides and antimicrobial additives
- **Dimensions:** 335 x 525 x 125mm
- **Weight:** 2.7kg

**Please specify your colour choice when ordering:**

White fleck, or Oatmeal

**HCF194.1** Magrini Wall Mounted Stay-Safe Baby Seat

**HCF801** Magrini Liner Dispenser



## Shuttleworth Soft Close Bins

Simple lid mechanism using the front pedal offers silent opening & closing of bin. Each bin is available with a variety of waste segregation coloured lids, supporting the safe management of healthcare waste and adherence to infection control guidelines.

- Fire retardant sack holder
- Manufactured from mild steel
- Pedal operated silent close with rear wheels for manoeuvring
- Powder coated in white epoxy for ease of cleaning
- **Dimensions (WxDxH):**
  - 20L: 275 x 340 x 500mm
  - 50L: 395 x 410 x 585mm
  - 70L: 395 x 410 x 750mm

**Standard waste segregation coloured lids available:**

- White (General Waste)
- Yellow (Waste for Incineration)
- Black (Domestic Waste - Municipal)
- Yellow & Black (Offensive/Hygiene Waste)
- Blue (Medical Waste for Incineration)
- Red (Anatomical Waste for Incineration)
- Orange (Waste Which May Be treated)
- Purple (Cytotoxic & Cytostatic Waste)
- Clear (Amalgam Waste)

**Shuttleworth**



**HCF1600** 20L Soft Close Bin - Specify Lid Colour

**HCF1609** 50L Soft Close Bin - Specify Lid Colour

**HCF1618** 70L Soft Close Bin - Specify Lid Colour

## Shuttleworth Sack Holder Bin

Our free standing, hands free sack holders are perfectly designed for waste disposal in hospitals and healthcare environments.

- Designed & manufactured with the high quality materials
- Created with corrosive resistant materials
- Easy to clean design with soft close lids via foot pedal
- Supplied fully assembled
- Elasticated cord and finger loop for securing waste bag
- **Dimensions (WxDxH):**
  - 20L: 586.9 x 235 x 277.9mm (818.9mm height with lid up)
  - 70L: 814.1 x 396.5 x 388.5mm (1133.8mm height with lid up)
  - 90L: 934.1 x 396.5 x 388.5mm (1253.8mm height with lid up)

**Standard waste segregation coloured lids available:**

- White (General Waste)
- Yellow (Waste for Incineration)
- Black (Domestic Waste - Municipal)

**Shuttleworth**



**HCF1830** 20L - White Lid - General Use

**HCF1831** 20L - Yellow Lid - Waste for Incineration

**HCF1832** 20L - Black Lid - Domestic (Municipal) Waste

**HCF1833** 70L - White Lid - General Use

**HCF1834** 70L - Yellow Lid - Waste for Incineration

**HCF1835** 70L - Black Lid - Domestic (Municipal) Waste

**HCF1836** 90L - White Lid - General Use

**HCF1837** 90L - Yellow Lid - Waste for Incineration

**HCF1838** 90L - Black Lid - Domestic (Municipal) Waste

## Sunflower Flame Retardant Waste Bins

The Sunflower range of Waste Bins are suitable for hospital, clinical and healthcare environments. Our hands-free, flame retardant bin range has been designed for the multi-function disposal of waste, and are compliant to HTM07-01 (Safe Management of Healthcare Waste). Usage is designated by an appropriate coloured lid and pedal label. They are also designed and tested to HTM83 fire resistance. Whether your requirement is for a hospital waste bin, a clinical waste bin for your doctors surgery/care home, or for any other healthcare environment, we are sure we have the bin for you. All the bins are silent closing as standard, of rust resistant construction and designed to be easy to clean.

- 20, 50 & 70 litre capacity
- Hygienic hands free operation, foot pedal must be used to open
- Safe management of healthcare waste compliant
- Designed & tested to HTM05-03 Part A
- Silent, dampened closing lid as standard
- Corrosion resistant epoxy coated white galvanised bodies
- Silicone bag retaining cord with nylon finger loop
- Stainless steel foot pedal with pedal label (where applicable)
- Sealed base prevents leakages
- Integrated wall mounting bracket
- Off the wall design to help prevent damage
- Flame retardant\*
- Easy clean design and materials
- **NEW** 5 year warranty

\* Designed and tested to HTM05-03 Part A

### 20 LITRE BINS

<b>SUN-BIN20-WHITE</b>	20 Litre Bin - White Lid
<b>SUN-BIN20-YELLOW</b>	20 Litre Bin - Yellow Lid
<b>SUN-BIN20-BLACK</b>	20 Litre Bin - Black Lid
<b>SUN-BIN20-YELL-BLK</b>	20 Litre Bin - Yellow/Black Stripe Lid
<b>SUN-BIN20-ORANGE</b>	20 Litre Bin - Orange Lid
<b>SUN-BIN20-PURPLE</b>	20 Litre Bin - Purple Lid
<b>SUN-BIN20-AMALGAM</b>	20 Litre Bin - White Lid - (with Amalgam Label)
<b>SUN-BIN20-BLUE</b>	20 Litre Bin - Blue Lid
<b>SUN-BIN20-RED</b>	20 Litre Bin - Red Lid

### 50 LITRE BINS

<b>SUN-BIN50-WHITE</b>	50 Litre Bin - White Lid
<b>SUN-BIN50-YELLOW</b>	50 Litre Bin - Yellow Lid
<b>SUN-BIN50-BLACK</b>	50 Litre Bin - Black Lid
<b>SUN-BIN50-YELL-BLK</b>	50 Litre Bin - Yellow/Black Stripe Lid
<b>SUN-BIN50-ORANGE</b>	50 Litre Bin - Orange Lid
<b>SUN-BIN50-PURPLE</b>	50 Litre Bin - Purple Lid
<b>SUN-BIN50-AMALGAM</b>	50 Litre Bin - White Lid - (with Amalgam Label)
<b>SUN-BIN50-BLUE</b>	50 Litre Bin - Blue Lid
<b>SUN-BIN50-RED</b>	50 Litre Bin - Red Lid

### 70 LITRE BINS

<b>SUN-BIN70-WHITE</b>	70 Litre Bin - White Lid
<b>SUN-BIN70-YELLOW</b>	70 Litre Bin - Yellow Lid
<b>SUN-BIN70-BLACK</b>	70 Litre Bin - Black Lid
<b>SUN-BIN70-YELL-BLK</b>	70 Litre Bin - Yellow/Black Stripe Lid
<b>SUN-BIN70-ORANGE</b>	70 Litre Bin - Orange Lid
<b>SUN-BIN70-PURPLE</b>	70 Litre Bin - Purple Lid
<b>SUN-BIN70-AMALGAM</b>	70 Litre Bin - White Lid - (with Amalgam Label)
<b>SUN-BIN70-BLUE</b>	70 Litre Bin - Blue Lid
<b>SUN-BIN70-RED</b>	70 Litre Bin - Red Lid



<b>20 Litre</b> 51cm(H) 32cm(W) 33cm(D)	<b>50 Litre</b> 59cm(H) 42cm(W) 43cm(D)	<b>70 Litre</b> 78cm(H) 42cm(W) 43cm(D)
--	--	--

## Sunflower Sack Holders

Our hands free sack holders are ideal for waste disposal in areas where the risk of fire is minimal. The range of free standing sack holders are constructed from the latest corrosion resistant materials. Ideally suited for janitorial supplies in areas where basic sack holders are required. Usage is designated by an appropriate coloured lid.

- 20, 70 & 90 litre capacity
- Hygienic operation, foot pedal should be used to open
- Elasticated bag retaining cord with nylon finger loop
- Corrosion resistant materials
- Safe management of healthcare waste compliant
- Designed & tested to HTM05-03 Part A
- Easy clean design and materials
- Supplied fully assembled
- **NEW** 5 year warranty

### 20 LITRE SACK HOLDERS

**SUN-BINSH20-WHITE** 20 Litre Sack Holder - White Lid

**SUN-BINSH20-YELLOW** 20 Litre Sack Holder - Yellow Lid

**SUN-BINSH20-BLACK** 20 Litre Sack Holder - Black Lid

### 70 LITRE SACK HOLDERS

**SUN-BINSH70-WHITE** 70 Litre Sack Holder - White Lid

**SUN-BINSH70-YELLOW** 70 Litre Sack Holder - Yellow Lid

**SUN-BINSH70-BLACK** 70 Litre Sack Holder - Black Lid

### 90 LITRE SACK HOLDERS

**SUN-BINSH90-WHITE** 90 Litre Sack Holder - White Lid

**SUN-BINSH90-YELLOW** 90 Litre Sack Holder - Yellow Lid

**SUN-BINSH90-BLACK** 90 Litre Sack Holder - Black Lid

**sunflower**  
HEALTHCARE FURNITURE



General Use



Waste for Incineration



Domestic (Municipal) Waste



## Plastic Freestanding Sack Holder



- All plastic construction with composite upright for added strength and durability
- Pedal operated with two large wheels for added mobility
- Split ring for easy bag fitting
- Base fitted with plugs to make cleaning simple
- Wipe-clean surface can be steam cleaned and jet washed
- Suitable for indoor and outdoor use
- Flat packed, assemble instruction included
- **Dimensions:** 935 x 560 x 520mm
- **5 lid colour options:** white, green, blue red and yellow

**HCF1260** White With Blue Lid

**HCF1261** White With Green Lid

**HCF1262** White With Red Lid

**HCF1263** White With Yellow Lid

**HCF1264** All White

## Hybrid Sackholders



- Metal Body with Plastic lid
- Hands Free Sack Retention Frame on both options
- Soft Closing Lid as standard on both options
- Smart & intelligent design that offers durability, ease of cleaning and a long lasting return-on-investment
- Bag leak collection tray to prevent unwanted leaks
- Non-Marking Lid and Base (protects the walls and floors)
- Fire Retardant to comply with the Department of Health technical memorandum, 'Fire Safety in The NHS (HTM-3)'

**Please specify lid colour when ordering:** Yellow, White, Tiger, Red, Purple, Blue, Orange, Green or Black

**HCF1344** 23L Plastic Lid & Metal Body (Specify Colour)

**HCF1345** 42L Plastic Lid & Metal Body (Specify Colour)

**HCF1346** 75L Plastic Lid & Metal Body (Specify Colour)



## Plastic Fire Retardant Sackholders

- 100% plastic and Rust free
- Various lid colours which are interchangeable
- Removable body available with larger bins for easy cleaning and aiding with manual handling (42L & 70L only)
- Hands-free function aids infection prevention (Foot pedal)
- Meets NHS England 'Managing Healthcare Fire Safety (HTM-05-03)' guidelines
- Available in 20L, 42L & 70L all with soft close lids
- Non-marking base and lid fitted to protect all floor types
- Off the wall lid design to prevent any marking of walls
- Fully integrated plastic pedal

**Please specify lid colour when ordering:** Yellow, White, Tiger, Red, Purple, Blue, Orange, Green or Black



**HCF1347** 20L Plastic Fire Retardant Sackholder (Specify Colour)

**HCF1348** 42L Plastic Fire Retardant Sackholder (Specify Colour)

**HCF1349** 70L Plastic Fire Retardant Sackholder (Specify Colour)

## Plastic Pedal Bins

Available in a range of sizes & colours, these bins are practical and lightweight, featuring a pedal opening.

- Pedal operated bin
- Complete with liner including ease use handle
- Available in either 12 or 20 Litre sizes
- Select your choice of white or yellow colour

### Bin Dimensions (Height x Diameter):

12 Litre: 340 x 270mm

20 Litre: 410 x 310mm



**HCF1003** White - 12 Litre with liner

**HCF1004** Yellow - 12 Litre with liner

**HCF1005** White - 20 Litre with liner

**HCF1006** Yellow - 20 Litre with liner

## Doherty Kendal Waste Bins

Designed specifically to suit the requirements of the modern surgery, nursing/care home or hospital

- Manufactured primarily from galvanised steel to exacting specifications
- Pull out handle to allow easy movement
- Designed to be difficult to open by hand, encouraging the use of the foot operated pedal: thus minimising the risk of cross contamination
- Silent closing feature means the lid closes slowly and quietly which also minimises the aerosol effect that could cause the spread of bacteria when the lid closes
- Fitted with wide pedal which allows the sack holder to be approached from the front and sides
- Fitted with rubber feet to prevent it marking the floor
- 6 month warranty
- Fully fire retardant to HTM 83

**Please specify lid colour when ordering:**

- White for domestic waste
- Yellow for clinical waste

**HCF797** 20 Litre Small - Select Lid Colour

**HCF798** 50 Litre Medium - Select Lid Colour

**HCF798.1** 50 Litre Medium w/ Removable Body - Select Lid Colour

**HCF799** 70 Litre Large - Select Lid Colour



	20L Small	50L Med	70L Large
<b>Height</b>	575mm	640mm	810mm
<b>Width</b>	220mm	410mm	410mm
<b>Depth</b>	350mm	440mm	440mm

## Plastic Pedal Step On Bins

- Pedal operated bin
- Available in 30, 45, 70 or 90 Litre sizes
- **Dimensions (W x D x H):**  
 30 Litre: 410 x 398 x 435mm  
 45 Litre: 410 x 398 x 600mm  
 70 Litre: 495 x 412 x 673mm  
 90 Litre: 412 x 500 x 820mm



**HCF1000** Grey - 30 Litre Bin

**HCF1000.1** White - 30 Litre Bin

**HCF1000.3** Yellow - 30 Litre Bin

**HCF1001** Grey - 45 Litre Bin

**HCF1001.1** Yellow - 45 Litre Bin

**HCF1001.2** White - 45 Litre Bin

**HCF1002** Grey - 70 Litre Bin

**HCF1002.1** Yellow - 70 Litre Bin

**HCF1002.2** White - 70 Litre Bin

**HCF1002.4** Grey - 90 Litre Bin

**HCF1002.5** Yellow - 90 Litre Bin

**HCF1002.6** White - 90 Litre Bin

## Quick Response Mopping Trolley

**Designed for the socket mopping of small/medium floor areas.**

- A compact trolley system designed for use in busy areas, where a quick and efficient response to cleaning is required.
- Simple to store, where space is an issue, these trolleys with its 3 inch swivel casters make it light and easily manoeuvred.
- The Quick Response Trolley comfortably holds the 15ltr socket mop bucket and wringer.
- The clip at the front secures the mop handle into place during transportation. There are hooks on the side of the trolley to hold items such as wet floor signs, dust pan and brushes etc.
- There is a caddy at the bottom to hold other items if required. The trolley features two 4 litre buckets holders, and a sack holder at the rear.



**HCF1852** Socket Mopping Trolley – Green 15L Bucket

**HCF1852.1** Socket Mopping Trolley – Yellow 15L Bucket

**HCF1852.3** Socket Mopping Trolley – Red 15L Bucket

**HCF1852.4** Socket Mopping Trolley – Blue 15L Bucket

## DARAY™ DX42 Series X-Ray Film Viewers

**DARAY™**  
Medical

Modern slim design, variable intensity, and independent & automatic panels that provide clear and diffuse illumination.

Utilising LED technology, the range provides a high intensity and is a highly efficient X-Ray Viewer with around 60,000 hours lamp life, meaning it costs significantly less to run.

With automatic film activation and variable brightness control, you have all the features you would need and more.

The DX42 Series is available as single and double wall-mounted units as standard, with triple and quad versions available on special order.

- Variable intensity: 4,000 - 10,000 lux
- Independently controllable panels
- Automatic film activation
- Only 25mm deep
- 60,000 hour life span

**HCF803** DX4201 – Single Panel LED X-Ray Viewer

**HCF804** DX4202 – Double Panel LED X-Ray Viewer

**HCF805** DX4203 – Triple Panel LED X-Ray Viewer(Special order)

**HCF806** DX4204 – Quadruple Panel LED X-Ray Viewer (Special order)



	DX4201	DX4202
<b>Voltage</b>	240v 90Hz	240v 90Hz
<b>Consumption</b>	30W	60W
<b>Dimensions</b>	480 x 505 x 25mm	840 x 505 x 25mm
<b>Visible Area</b>	360 x 422mm	720 x 422mm

## Infection Control

We supply a varying array of infection control products suitable for cleaning and personal protection in industry. These include a range of products typically used on a day to day basis within the NHS for infection control purposes:

- Facemasks and visors
- Personal protective equipment
- Disinfectants and sprays
- Clinell products

Contact our helpful sales team for assistance with your requirements. See this product range online: [www.hce-uk.com/infection-control](http://www.hce-uk.com/infection-control)

- Hands soaps/ rubs
- Gloves
- Instrument cleaners
- Cleaning equipment/ furniture



View this range online at: [www.hce-uk.com/consumables](http://www.hce-uk.com/consumables)



## Clinispin Horizon Centrifuges

### Set & Lock Routine Centrifuges

Minimise error, reduce training time and deliver the best patient outcome with Clinispin horizon Set & Lock Routine Centrifuges.

**Horizon 6:** ideally suited where space is at a premium and consistency is key

**Horizon 12:** Designed for midsize routine labs with an emphasis on repeatability

**Horizon 24:** Perfect for high volume labs seeking operational standardisation

- 2 stage horizontal rotor. Patented swing-out design produces ideal horizontally separated samples.
- Set & lock validated cycles to prevent accidental changes
- 3 preset cycles
- 6, 12 and 24 tube capacity
- Erasable label for custom cycles
- Easy-to-use 2-button interface
- Easy to Monitor with LED Lid Lighting – off when the centrifuge is ready to load, on when running and flashing at the end of the cycle
- Built to Last, no routine maintenance required, brushless motor, engineered composite components
- Engineered for Safety. Protect your lab with imbalance detection and a shatterproof lid which can only be opened when the rotor is stopped, even if the unit loses power

**Tube Capacity:** 6, 12 or 24 (75-100mm/3-10mL)

**Applications:** Chemistry, Coag, PPP, PRP, Urine

**Centrifugation:** Horizontal (max 2,000xg/3,800 RPM)

**Includes:** Rotor, buckets and tube holders, cycle label

### Dimensions (H x W x D) and Weight:

- Clinispin horizon 6: 23 x 30 x 36cm, 5.4kg
- Clinispin horizon 12: 23 x 33 x 38cm, 13.7kg
- Clinispin horizon 24: 23 x 38 x 43cm, 14kg



**LAB232** Clinispin horizon 6 – 6-place horizontal rotor and 6x5-10ml tube carriers

**LAB234** Clinispin horizon 12 – 12-place horizontal rotor and 12x5-10ml tube carriers

**LAB235** Clinispin horizon 24 – 6 carrier horizontal rotor, 6x4-place carriers, 6x50ml carriers and 6x carrier caps

## Clinispin Horizon Flex Centrifuges

### Programmable Routine Centrifuges

Satisfy the most diverse processing requirements with Clinispin horizon Flex Routine Centrifuges. Customise settings and check every detail on the digital display or pre-programme up to 10 cycles.

**Horizon 6 Flex:** ideal for small routine labs spinning a variety of samples or seeking a centrifuge with a fully digital display

**Horizon 12 Flex:** ideal for medium labs with a variety of sample preparations, or where a digital display is desirable

**Horizon 24:** ideal for large labs with many varied specimen preparations or needing to the second cycle countdown

- Programmable and easy to use with digital display
- 6, 12 and 24 tube capacity with 10 programmable settings
- 2 stage horizontal rotor. Patented swing-out design produces ideal horizontally separated samples.
- User friendly 5-button interface
- Spin 75-100 mm (3-10mL) tubes without switching tube holders or adding cushions
- Easy to Monitor with LED Lid Lighting – off when the centrifuge is ready to load, on when running and flashing at the end of the cycle
- Built to Last, no routine maintenance required, brushless motor, engineered composite components
- Engineered for Safety. Protect your lab with imbalance detection and a shatterproof lid which can only be opened when the rotor is stopped, even if the unit loses power

**Tube Capacity:** 6, 12 or 24 (75-100mm/3-10mL)

**Applications:** Chemistry, Coag, PPP, PRP, Urine

**Centrifugation:** Horizontal (max 2,000xg/3,800 RPM)

**Includes:** Rotor, buckets and tube holders, cycle label

### Dimensions (H x W x D) and Weight:

- Clinispin horizon 6 Flex: 23 x 30 x 36cm, 5.4kg
- Clinispin horizon 12 Flex: 23 x 32 x 39cm, 13.7kg
- Clinispin horizon 24 Flex: 23 x 38 x 43cm, 14kg



**LAB236** Clinispin horizon 6 Flex – 6-place horizontal rotor and 6x3-10ml tube carriers

**LAB238** Clinispin horizon 12 Flex – 12-place horizontal rotor and 12x3-10ml tube carriers

**LAB239** Clinispin horizon 24 Flex – 6 carrier horizontal rotor, 6x4-place carriers, 6x50ml carriers and 6x carrier caps

## Clinispin Horizon Fixed Angle Centrifuges

**Fixed Angle Routine Centrifuges** – Spin 125mm tubes and meet fixed angle processing needs for PRP, urine and more with Clinispin horizon Fixed Angle Routine Centrifuges.

**Horizon 6 Flex FA:** digital display and 10 programmable cycles

**Horizon 6 FA:** Simple two-button operation to select a preset cycle or lock to a single cycle

- Easy to Use - Simple two button operation to select a preset cycle or lock to a single cycle
- Fixed Angle Rotor - Separate specimens at fixed angle of 45°
- 6 Flex FA is fully programmable - Save and recall 10 easily customisable cycle settings
- Programme and recall 10 cycles on the Clinispin Horizon 6 Flex FA through the digital display
- Both spin 75-100mm (3-10mL) tubes in the same holder without cushions, or 125mm (15 mL) tubes in the included additional tube holders
- LED Lid Lighting – off when the centrifuge is ready to load, on when running and flashing at the end of the cycle
- Built to Last, no routine maintenance required, brushless motor, engineered composite components
- Engineered for Safety. Protect your lab with imbalance detection and a shatterproof lid which can only be opened when the rotor is stopped, even if the unit loses power

**Tube Capacity:** 6, (75, 100 or 125mm/3-15mL)

**Applications:** PRP, Chemistry, PPP, Coag, Urine

**Centrifugation:** Fixed Angle (max 1,850 xg/3,900 RPM)

**Includes:** Rotor and tube holders

**Dimensions (H x W x D) and Weight:**

- Clinispin horizon 6 Flex FA: 23 x 30 x 36cm, 5.4kg
- Clinispin horizon 6 FA: 23 x 30 x 36cm, 5.4kg



**LAB237** Clinispin horizon 6 Flex FA – 6-place fixed angle rotor, 6x5-10ml and 6x15ml tube carriers

**LAB233** Clinispin horizon 6 FA – 6-place fixed angle rotor, 6x5-10ml and 6x15ml tube carriers

## DASH Centrifuges

Easy to use high g-force centrifuges, pre-programmed to provide STAT processing of gel or non-gel tubes.

- Rapid horizontal separation
- Clear shatterproof lid with interlock system
- No routine maintenance
- 2 Stage horizontal rotor
- Brushless DC Motor
- Cool operation
- 3 preset levels up to 4,000g for 3, 5 or 7 minutes ideal for some manufacturers specialist blood tubes

### Safety Guarantee

- **Automatic Lid Lock** - Centrifuge will not run with the lid open and the lid cannot be opened while samples are spinning
- **Positive Lid Latching** - Firm mechanical latching of the lid prevents the escape of debris in case of tube breakage
- **Clear Shatterproof Lid** - Safe observation and access for tachometer, made from a high strength polycarbonate
- **Regulatory Approvals** - Certified to US, Canadian and European Safety standards
- **Reinforced Guard Bowl** - Advanced engineering composite resins provide maximum safety and durability

### Applications

STAT Specimen Processing, Chemistry, Coagulation, General Purpose and Veterinary Practices



**LAB240** Drucker Dash, Apex 6 – 6-place horizontal rotor and 6x5-10ml tube carriers

**LAB241** Drucker Dash, Apex 12 – 12-place horizontal rotor and 12x5-10ml tube carriers

**LAB243** Drucker Dash, Flex 12 – 12-place horizontal rotor and 12x5-10ml tube carriers

**LAB242** Drucker Dash, Apex 24 – 6 carrier horizontal rotor, 6x4-place carriers

	DASH Apex 6	DASH Apex 12	DASH Flex 12	DASH Apex 24
<b>Centrifuge Capacity</b>	6 tubes up to 17mm x 75 - 100mm	12 tubes up to 17mm x 75 - 100mm	12 tubes up to 75 - 100mm	24 tubes up to 17mm x 75 - 100mm
<b>Dimensions (H x W x D)</b>	20 x 28 x 34cm	23 x 32 x 38cm	23 x 32 x 38cm	23 x 37 x 43cm
<b>Weight</b>	5.4kg	13.7kg	13.7kg	17kg
<b>Max. Acceleration/Deceleration Times</b>	20/20 seconds	35/40 seconds	35/40 seconds	45/40 seconds
<b>Frequency</b>	50/60Hz	50/60Hz	50/60Hz	50/60Hz
<b>Max. Speed</b>	5300 RPM	5200 RPM	5200 RPM	4200 RPM
<b>Cycle Time</b>	1 - 30 minutes (+/- 2%)	1 - 30 minutes (+/- 2%)	1 - 30 minutes (+/- 2%)	1 - 30 minutes (+/- 2%)
<b>Voltage</b>	95 - 253 VAC	95 - 253 VAC	95 - 253 VAC	95 - 253 VAC

## LMC-4200R Benchtop centrifuge

Benchtop centrifuge with refrigeration with interchangeable rotors for accommodating centrifuge tubes (10 to 15 ml or 50 ml) or microplates as required.

- Spin speed: up to 4200rpm (tubes) up to 2000rpm (plates)
- Temperature setting range: -10 to 25°C
- Timed operation (1 to 90 minutes) with automatic switch-off
- 'Soft-start' and 'run-down' functions
- Interchangeable rotors for up to 12 tubes or 2 microplates
- Auto 'IMBALANCE' stop and warning diagnostics
- Sturdy metal housing and lid, automatic imbalance switch-off and lid lock when centrifuge is running for safety
- Acceleration (run-up up 15 sec.) and deceleration (run-down up to 30 sec)
- Refrigeration rate inside the chamber under 10 mins
- Easy set-up of speed and time via LCD display and simple push buttons display of actual and set temp, speed and time
- Compact design with small footprint for space saving



**LAB251** Centrifuge with refrigeration (Order rotor separately)

## Microspin 12 Microcentrifuge

Compact high-speed benchtop mini centrifuge with a built-in rotor for 12 x 1.5/2ml microtubes. Ideal for biomedical laboratories and life science uses.

- Centrifugation speed: 100-14,500 rpm, RCF 12 400xg
- Fixed angular aluminium rotor accommodates 12 x 1.5/2 ml microtubes, supplied with adapters for 0.2ml and 0.5ml tubes
- Timed operation (1 to 30 minutes), with automatic switch-off
- Suitable to use in cold rooms at operating ambient temperatures from +4°C to +25°C
- Metal protective inserts inside the lid and casing, automatic imbalance switch-off and locking of a lid for safety
- Constant airflow around the rotor reduces risk of samples overheating
- Simple push-buttons and a clear 2-line LCD display shows actual and set values of time, set and actual speed and relative centrifugal force
- Rotor diagnostics: automatic stop, "imbalance" warning
- Quick spin function - Now starting from 15 seconds



**LAB252** Microcentrifuge 12 x 1.5ml (includes rotor & adapters)

## CVP-2 PCR Centrifuge/Vortex

All-in-one PCR plate centrifuge / vortex mixer that allows for the simultaneous sample preparation of multiple samples at one time. Versatile through being able to hold un, semi and fully skirted PCR plates with no additional accessories required.

**The CVP-2 offers 3 devices in one:** Centrifuge with vortex mixing, PCR plate centrifuge and PCR plate mixer

- Centrifuge/vortex mixer combined for significant time saving
- Centrifugation mixing speed: 300 to 1500 rpm as required
- Independent vortex/centrifuge timers with up to 999 cycles
- Adjustable rpm or 4 programmable presets for ease of use
- Consistently prepare up to 192 samples continuously



**LAB255** CVP-2 All-in-one PCR Centrifuge/Vortex

## LMC-3000 Low Speed Centrifuge

A low speed benchtop centrifuge for biomedical applications. It has interchangeable rotors for accommodating centrifuge tubes (10 to 15 ml or 50 ml) or standard 96-well microtitre plates.

- Spin speed: up to 3000 rpm (tubes), up to 2000 rpm (plates)
- Timed operation (1 to 90 minutes), with automatic switch-off
- Interchangeable rotors which allow for up to twelve tubes or two microtitre plates
- Easy set-up of spin speed and time via 2-line LCD display
- Sturdy metal housing and lid, automatic imbalance switch-off and lid lock when centrifuge is running provide for safe operation in your workplace
- Strong, quiet motor has 'soft' start-up/run-down to prevent damage to samples.



**LAB256** Benchtop Centrifuge 0-3000rpm (Order rotor separately)

## Combined Centrifuge/Vortex Mixer

Cost-effective combined centrifuge/vortex mixers for combined or independent centrifuge and mixing applications of microtubes and 0.2 ml microtube strips in low volume applications.

- **PCV-2400:** 2800rpm (50Hz) and 3500rpm (60Hz)  
Vortex cup emerges through an opening in lid, enabling individual tubes to be mixed while a full load is spinning. Easy to use with simple buttons on face of unit.
- **PCV-6000:** 1000 to 6000rpm as needed  
Multi-spin enables consecutive spin and mix phases of multiple tubes providing a saving on.  
Clear 2-line LCD display enables accurate setting of unit
- Compact design and extremely quiet in operation – fits neatly and unobtrusively into the workspace
- Very easy to use with cost saving features.



**LAB253** PCV-2400 Mixer to 3500rpm (Includes rotors)

**LAB254** PCV-6000 Mixer to 6000rpm

## Clinispin CT20 Centrifuge

Small, lightweight, easy to use centrifuge designed for quick production of PPP (platelet poor plasma) and PRP (platelet rich plasma) as well as other applications in the laboratory.

- High speed and g-force
- PPP and PRP production in 2 minutes
- Removable rotor with 6 x 10/15ml
- Complete with adapters for common blood draw tubes
- Variable speed in 100 RPM increments
- Speed control: Digital - variable (100 RPM increments)
- Timer: 30 sec to 30 min with continuous hold features
- Accelerates in 14 seconds and Decelerates in 27 seconds
- **Max. speed:** 6,500 RPM
- **Max. capacity:** 6 x 15ml
- **Dimensions:** 18 x 21 x 24cm
- **Weight:** 4 kg



**LAB110** Clinispin CT20 Centrifuge

## Clinispin CT25 Centrifuge

The essential centrifuge for Blood Processing in Clinics/Hospitals and other Diagnostic Research Labs. The Clinispin CT25 is a lightweight, portable, maintenance free centrifuge designed for blood centrifugation & other clinical applications including PRP.

- Variable speed with precise RPM/RCF setting from 500 to 6500 RPM with least count of 100 RPM
- Brushless DC Motor for maintenance free long life
- Microprocessor Controlled Centrifuge with digital display
- Automatic imbalance detection for safe operation
- Lid lock safety - releases automatically after run completion
- Timer setting 1 to 30 minutes & infinite mode
- Universal voltage and maintenance free
- Accommodates most common collection tubes - comes with adaptors for 5ml, 7ml & 1.5/2ml tubes
- Supplied with 8 x 15ml rotor
- One switch change over from RPM to RCF
- Smart air flow design for quiet operation and low temp. rise
- Automatic imbalance detection for safe operation
- **Dimensions (WxDxH):** 260 x 244 x 205mm
- **Weight:** 4kg



**LAB110.1** Clinispin CT25 Centrifuge

### MSH-300i Magnetic Hotplate Stirrer

Designed for laboratories with higher requirements. Offers digital setting and control of temp and rotation speed. A magnet allows mixing solutions with glycerine viscosity level. The maximum volume of stirred liquid is 20 Litres.

- Adjustable speed: 100 to 1250rpm
- Maximum stirring volume: 20 litres
- Overheat protection
- Aluminium alloy plate
- Stirrer bar and retort stand included

**Applications**

- Clinical/Healthcare: Thawing/heating/stirring samples
- Pharmaceutical: Heating and stirring
- Science education (school/university): demos and experiments



**LAB257** Digital Magnetic Hotplate Stirrer (Includes stirring bar)

### MMS-3000 Magnetic Stirrer

A compact magnetic stirrer for handling small volumes in lab procedures such as pH metering, extraction and dialysing.

- Adjustable speed control: 0 to 3000 rpm
- Stirring volume: 20 litres
- Quiet operation, small size – fits neatly into the workspace
- Easy to use graduated dial for quick and convenient selection of speed
- Rugged stainless steel plate provides a working surface of 110 x 110 mm
- Supplied with a stirrer rod

**Applications**

- PH metering, extraction and dialysing with small quantities
- Any requirement for stirring up to 20 L



**LAB258** MMS-3000 Magnetic Stirrer (Includes stirring bar)

### Orbital Shaking Multi-Platform

Microprocessor-controlled shaking platforms for smooth and quiet horizontal motion for mixing in bottles, flasks and beakers.

- **PSU-10i:** 50 to 450 rpm with loads up to 3 kg
- **PSU-20i:** 20 to 250 rpm with loads up to 8 kg
- Reciprocal rotation, Vibration and All mixing functions
- Interchangeable platforms for use with a variety of vessels
- Reliable direct drive system
- Very easy to operate, with simple set-up and use
- Powerful, reliable and exceptionally quiet motor
- 2-line LCD display clearly indicates both set and actual shaking speed, plus set and elapsed time.

**LAB260**



Platform options are available **enquire for details**



**LAB261**

**LAB260** PSU-10i Orbital Shaker (Order platform separately)

**LAB261** PSU-20i Orbital Shaker (Order platform separately)

### PMS-1000i Microplate Shaker

A compact magnetic stirrer for handling small volumes in routine laboratory procedures such as pH metering, extraction and dialysing.

- Adjustable speed control: 0 to 3000 rpm
- Stirring volume: 20 litres
- Quiet operation, small size – fits neatly into the workspace
- Easy to use graduated dial for quick and convenient selection of mixing speed as needed
- Stainless steel working surface of 110 x 110 mm
- Platform fits 2 plates (platform for 4 microplates available)
- Supplied with a stirrer rod

**Applications**

- PH metering, extraction and dialysing with small quantities
- Any requirement for stirring solutions up to 20 litres



**LAB259** PMS-1000i Microplate Shaker (For 2 plates)

### MPS-1 High Speed Shaker/Vortex Mixer

An economical solution that takes up very little bench space, for all high-speed shaking and vortex mixing of plates and tubes from 0.2ml through to 50ml. Efficient mixing of difficult samples e.g. compact pellets, small or viscous samples.

- Very competitive market price vs. specification
- Shaker / vortex mixer combined
- LCD 2 line display of set and actual values
- Can be used in cold rooms and incubators
- Grant renowned technical and service support
- Adjustable rpm or 4 presets
- Safe in humid environments
- Very small footprint
- Quiet < 50dB
- Timer with alarm
- **2 year warranty**



**LAB264** MPS-1 Shaker/Vortex Mixer for Microplates and Microtubes



## Jenway® 7205 Series Spectrophotometers

the first scanning spectrophotometers in the Jenway range to leverage diode array technology to produce exceptionally fast results. Covers a wavelength range of 198 to 800nm with a spectral bandwidth of 5nm.

Ideal for applications in education and routine testing in clinical, veterinary, pharmaceutical and QC laboratories. The large sample chamber will easily accommodate the optional long path length cuvette holder and the heated 10x10mm cuvette holder which is ideal for thermostated measurements at 37°C.

- Scanning diode array technology
- Colour touchscreen navigation
- Small footprint and lightweight
- Fast scan speed
- English, French and German language options
- Multiple USB ports for data storage and printer connectivity



2 Year  
Warranty



LAB245 72 Series Spectrophotometer

## Jenway® 74 and 76 Series Spectrophotometers

Provide accurate and reliable results in various applications from teaching, to industrial, to routine sample analysis in QC environments. Both units include colour touchscreen and intuitive user interface, allowing manual free operation.

Offer measurement modes for simple photometrics; concentration calculated using a single standard or a factor; quantitation with the ability to create a calibration curve using up to 20 standards; full spectrum scanning; multi-wavelength, where up to 4 wavelengths can be measured simultaneously and kinetics, to monitor the change in absorbance over time.

- 7" High Definition colour touchscreen display
- Android operating system
- Internal memory for methods and results (3.6GB storage)
- Multiple USB ports for data storage and printer connectivity
- Multi-language: English, French, German, Spanish and Italian



LAB246 74 Series Spectrophotometer

LAB247 76 Series Spectrophotometer

## Jenway® 7415 Nano Scanning Micro-Volume Spectrophotometer

Fitted with a micro-volume accessory enabling sample volumes as low as 0.5 µL to be pipetted directly onto the read head, removing the need for cuvettes and conserving valuable samples.

With CPLive connectivity, you can upload results and protocols safely and securely to the cloud, share data with your colleagues, and manage multiple devices through the CPLive app on your computer, tablet, or smartphone. All your information, from one or multiple instruments, is now stored in one secure location.

- Easy to use 7" high-definition colour touchscreen/interface
- Versatile and compatible with a wide range of interchangeable accessories
- Simple connectivity with USB ports for data and printers
- Choice of measurement modes let you handle a multitude of applications



LAB248 7415 Nano Scanning Micro Volume Spectrophotometer

## 3540 Bench Conductivity/pH Meter

Ideal for use in all laboratories where pH and conductivity analyses are required. The setup menu gives simple access to the whole range of instrument, pH and conductivity options.

Auto calibration of both channels, with the option to select 1, 2 or 3 calibration points. The pH channel can also display mV values.

- Simultaneous display of pH and conductivity
- 2 independent channels to prevent probe interference
- Additional modes for resistivity, salinity, TDS and mV
- Data logger with auto save/print options
- Storage of up to 500 readings (250 for each mode)
- **Supplied with:** glass combination pH electrode (924 005), glass conductivity probe (K=1, 027 013), electrode stand and holder, ATC probe (027 500), BNC shorting plug, pH buffers and UK power supply.
- **Dimensions:** 210 x 250 x 55mm
- **Weight:** 850g



3 Year  
Warranty



LAB064 3540 Bench Combined Conductivity/pH Meter

## PFP7/C Clinical Flame Photometer



3 Year  
Warranty



The PFP7/C is a low temperature, single channel flame photometer that is specifically designed for use in clinical applications for the determination of sodium, potassium and lithium.

The in-built lineariser circuitry of the PFP7/C enables readings of both sodium and potassium to be displayed directly in mmol/l.

- Designed for clinical analysis
- Supplied with Na, K and Li filters
- Low temperature, single channel
- Flame failure safety system
- **Operates with:** propane, butane, natural gas or LPG
- **Dimensions:** 420 x 360 x 300mm / **Weight:** 8kg
- **Supplied with:** Na, K and Li filters, connecting hoses and clips, compressor plug and drain trap

LAB065 PFP7/C Clinical Flame Photometer

## 3510 Bench pH/mV Meter



3 Year  
Warranty



A versatile, simple to use pH, mV and temperature meter. Up to three decimal place resolutions and a choice of up to three calibration points, providing the user with added flexibility. A choice of pH calibration buffers to DIN, JIS and NIST standards can be used for automatic calibration, as well as manually entered buffer values.

- Simultaneous readout of pH and temperature
- pH resolution to 3 decimal places & up to 3 point calibration
- Multiple Automatic buffer options or Manual buffer selection
- Storage of up to 32 results
- RS232 connection to printer or PC via DataWay
- **Outputs:** Analogue and RS232
- **Dimensions:** 210mm x 250mm x 55mm / **Weight:** 850g
- **Supplied with:** glass combination pH electrode (924 005), electrode stand and holder (903 300), ATC probe (027 500), BNC shorting plug, pH 4, 7 and 10 buffers, UK power supply

LAB116 3510 Bench pH/mV Meter

## Omni OS1025 Reaction Station

The OS1025 STEM Omni Reaction Station enables you to run up to 10 reactions simultaneously at the same controlled temperature and stirring rate. The modular design of the OS1025 Omni Reaction Station means that the same base unit (OMCA) can accommodate a variety of cartridges and sample volumes from 1 to 1000ml.



All heating blocks, glassware and reflux heads are also interchangeable. In addition, its compact footprint means that it can be placed into any fume hood or onto a small bench space.

- Greater stirring stability and stir speeds of 100- 800 rpm
- Simple menus and touchpad interface to control the system
- All heater cartridges are equipped with "in block heaters" that allow temperatures up to 220°C
- High level of stability ( $\pm 1.5^\circ\text{C}$ ) across the heater cartridge itself
- An external temperature probe to increase temperature accuracy to 0.5°C
- An outer casing to retain the "cool to touch" safety feature that so many of our customers value
- Can also be used in conjunction with a cooling plug to extend the temperature range from - 30°C to 220°C
- Number of positions: 10
- **Dimensions:** 300 x 330 x 300mm / **Weight:** 10kg

LAB135 Omni OS1025 Reaction Station

## Integrity 10 Reaction Block



Enables you to conduct 10 different reactions simultaneously within the same reaction block, each reaction being conducted within its own cell, at its own individual temperature and stir rate. If desired, fast heating and cooling rates can be selected, with temperature ramps of between 0.1°C/min to 5°C/min.

- 10 individual cells in one reaction block
- Individual control of temperature & stirring rate for each cell
- Temperature range of -30°C to 150°C
- Stirring rate of 380rpm-1200rpm
- Cell working volume of 1ml-25ml
- Automatic microprocessor control through a touchscreen
- Optional PC Software for external control and extra functions
- Optional attachments for refluxing, and working under vacuum or inert gas conditions
- Optional multi-infrared probes: soluble/crystallisation studies

LAB136 Integrity 10 Reaction Block

## SI Shaking Series Incubators

Combined shaker/incubators ideal for cell culturing procedures, especially suspension culture. Can positioned on the lab bench.

The incubators feature smoked acrylic windows in the door and to both sides to allow easy visibility of the samples. The SI600C all windows are also double glazed to prevent condensation.

These shakers provide an orbital shaking motion, adjustable between 30 to 300rpm with a gentle start action. The shaking speed is microprocessor controlled and set digitally.

Includes a versatile digital timer which can be set from 1 sec to 9 days. When complete the shaking action will stop and an alert will sound, as a safety feature the incubator will continue to run.



**LAB139** SI500 Shaking Incubator (51L Capacity)

**LAB140** SI600 Large Shaking Incubator (115L Capacity)

**LAB140.1** SI600C Large Shaking Incubator Cooled

	<b>SI500</b>	<b>SI600</b>	<b>9600C</b>
<b>Net weight</b>	30kg	53kg	60kg
<b>Ext. Height</b>	522mm	640mm	640mm
<b>Ext. Depth</b>	474mm	542mm	542mm
<b>Ext. Width</b>	450mm	675mm	675mm
<b>Int. Height</b>	297mm	395mm	380mm
<b>Int. Depth</b>	408mm	455mm	465mm
<b>Int. Width</b>	422mm	625mm	625mm
<b>Max Vessel Height</b>	250mm	320mm	320mm
<b>Platform size</b>	335 x 335mm	525 x 390mm	525 x 390mm

## Stuart Orbital Shakers

These orbital shakers provide a smooth, uniform circular motion with a 16-mm orbit – ideal for larger samples and multi-well plates. Easily set and view the speed and the timer on the LED display. Control speed from 30 to 300 rpm.

The microprocessor maintains speed accuracy even over long runs. Built-in timer can be set from 1 to 999 minutes. When timer reaches zero, the shaker automatically stops and sounds an alert.

- Smooth orbital shaking action with 16-mm orbit
- Built-in timer and digital speed LED display provide reproducible results
- Can be used in incubators
- Cradle system with four rubber securing bars hold flasks, bottles, and beakers securely in place
- 230 VAC operation
- Max load: Large 10kg, Mini 3kg
- 3 year warranty

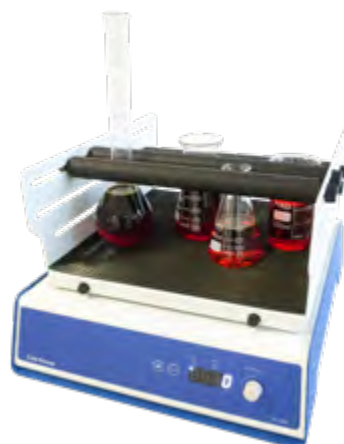

**LAB720** Stuart Large Orbital Shaker - 13" Square Platform

**LAB725** Stuart Mini Orbital Shaker - 8" Square Platform

## Stuart Gyro Rocking Shakers

Feature a 3D gyrating action with a 3 to 12° tilt angle. Easily adjust the angle of the tilt by hand. Best suited for low-foaming requirements. Easily set view the speed and the timer on the LED display. Control speed from 5 to 70 rpm.

The microprocessor maintains speed accuracy even over long runs. Easily set digital timer from 1 to 999 minutes. When timer reaches zero, the shaker automatically stops and sounds an alert.

- Adjust tilt angle for optimal mixing
- Platform lip and nonslip mat hold vessels securely in place
- Built-in timer and digital speed LED display provide reproducible results
- Can be used in incubators
- Compact design is perfect where space is tight
- 230 VAC operation
- Max load: Large 10kg, Mini 3kg
- 3 year warranty



**LAB722** Stuart Large Gyro Rocking Shaker - 13" Square Platform

**LAB726** Stuart Mini Gyro Rocking Shaker - 8" Square Multi-Platform

## Stuart Large Reciprocating Shaker

These linear reciprocating shakers feature digital speed selection from 25 to 250 rpm with a soft start. Four adjustable rubber cushioned horizontal securing bars with quick release handles on the cradle-type platform allow you to fit nearly any size flask, bottle, or beaker. Secure up to twelve 250-mL, nine 500-mL, four 1-L, or two 2-L vessels.

Easily set digital timer from 1 to 999 minutes. When timer reaches zero, the shaker automatically stops and sounds an alert. Shaker is capable of continuous use, and the microprocessor maintains speed accuracy over long runs.

- Digital speed selection provides consistent mixing
- Soft-start motor prevents spills and splashes
- Fully adjustable cradle accommodates most flasks, bottles, and beakers
- Can be used in incubators system
- 230 VAC operation
- 3 year warranty



**LAB721** Stuart Large Reciprocating Shaker - 13" Square Platform

## Stuart Microplate Shakers

These microplate shakers combine high speed and a tiny 1.5-mm orbit to produce vigorous shaking perfect for microwell plates. The shakers offer a quiet drive mechanism, easy-to-use controller with timer, LED display, and a digital speed selection from 250 to 1250 rpm with a soft start.

Easily set digital timer from 1 to 999 minutes. When timer reaches zero, the shaker automatically stops and sounds an alert. Shaker is capable of continuous use, and the microprocessor maintains speed accuracy over long runs.

- Nonslip mat and platform lip securely hold plates
- Built-in timer and digital speed LED display provide reproducible results
- Can be use in incubators
- Holds eight microplates simultaneously
- 230 VAC operation
- Capacity: Large 8 plates, Mini 4 plates
- 3 year warranty

## Stuart See-Saw Rocking Shakers

These see-saw rocking shakers provide a gentle rocking action at a 7° tilt angle, perfect for culture flasks and Petri dishes. Easily set and view the speed and the timer on the LED display. Control speed from 5 to 70 rpm. The microprocessor maintains speed accuracy even over long runs. Easily set digital timer from 1 to 999 minutes. When timer reaches zero, the shaker automatically stops and sounds an alert.

Durable shakers are rated for continuous use. Use in incubators and environmental or cold chambers up to 104°F (40°C).

- Nonslip mat and platform lip hold vessels securely in place
- Built-in timer and digital speed LED display provide reproducible results
- Can be used in incubators
- Large platform easily accommodates multiple vessels
- 230 VAC operation
- Max load: Large 10kg, Mini 3kg
- 3 year warranty

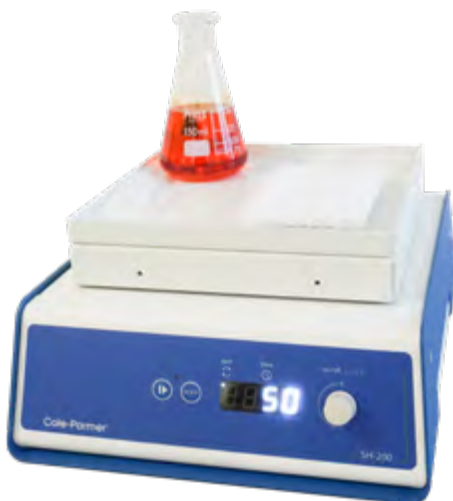

**LAB724** Stuart Large Microplate Shaker - 8 Plates

**LAB723** Stuart Large See-Saw Rocking Shaker- 14" Square Platform

**LAB728** Stuart Mini Microplate Shaker - 4 Plates

**LAB727** Stuart Mini See-Saw Rocking Shaker - 9.5" Square Platform

## Biological Stirrer

Designed for optimal suspension cell culture and the use of microcarriers. The system comprises of a stirrer platform and a number of glass culture vessels. Incorporates a design which, together with the bulb-ended stirrer, ensures that the cells are lifted to suspension at the lowest possible speeds.

Cell attachment to microcarriers and high cell yields are ensured by the soft start/stop design and interval stirring. The former ensures slow acceleration/deceleration, avoiding excessive turbulence in culture media, eliminating cell damage. Interval stirring can be used during the attachment phase to further reduce agitation of media or for culturing fragile cells.

- Speed range from 0 to 80rpm with Interval setting option
- Soft start/stop for slow acceleration and deceleration (20 sec)
- Stainless steel platform with locators for the culture vessels
- Designed for environments up to 40°C and 95% humidity
- **Dimensions:** 395 x 495 x 90mm
- **Power consumption:** 2W



LAB159 Biological Stirrer FMCS104L

## Stuart SA8 Vortex Mixer

Mixing speed can be selected from 200rpm for very gentle mixing to 2500rpm for vigorous agitation. Choose between 'touch' mode or continuous operation with a single button.

Robust die-cast body avoids unnecessary movement during use. Ergonomic, slim design is comfortable for the user. Integral retort rod fixing allows vessels to be secured above the vortex action for long-term mixing.

- Intermittent or continuous mode
- Stable low profile body
- **Variable speed control:** 200 and 2500rpm
- **Dimensions:** 135 x 215 x 78mm
- **Weight:** 3.2kg



LAB086 Stuart SA8 Variable Speed Vortex Mixer

## Handheld Homogeniser

A powerful, variable speed, homogeniser. The high-speed, high-torque motor makes the unit ideal for most homogenising applications. Lightweight, making it comfortable to use, and most samples can be processed within thirty seconds.

For longer processing the unit can be stand mounted using the included post clamp assembly. Use with stainless steel or polycarbonate disposable probes.

- Variable 125w motor speed 5,000–35,000RPM
- Processing range from 0.03ml-100ml
- Sound level <72dB
- **Dimensions:** 160 x 55mm
- **Net Weight:** 0.5kg



LAB150 Handheld Homogeniser

## Biological Stirrer

The Geno/Grinder® is an automated high-throughput plant & animal tissue homogenizer and cell lyser. It is equipped with an adjustable clamp that accommodates a full range of sample vials from 2mL to 50mL centrifuge tubes or up to six deep-well titer plates. It is specifically designed for rapid cell disruption, cell lysis and tissue homogenization through bead beating. This enables fast and efficient extraction of nucleic acids, proteins and other molecules.

- Auto-mechanical disruption through bead beating, ideal for high-throughput cell lysis applications including DNA/ RNA extraction, protein extraction and pesticide residue analysis.
- Programmable touchscreen controller for run time, rate, cycles and pause time. Up to 500 protocols can be saved for recall.
- Designed for vigorous up-and-down shaking of deep-well titer plates, vial sets, and centrifuge tubes.
- Comes with an adjustable clamp with a quick release button that allows users to secure vials or titer plates of various sizes.
- Typical sample processing time of 1-2 minutes.



LAB159

## Stuart Undergrad Range

Includes dedicated hotplates, stirrers, and combination hotplate stirrer models, which are available in a choice of coated metal or ceramic tops. With standard electrical supply of 230V, 50hz.

The square (150 x 150mm) design of the hotplate allows flexibility of vessel sizes and combinations; e.g. four 250 mL beakers can easily fit on the hotplate surface at the same time.

Powerful magnets and motors allow remarkable stirring speeds (up to 2000 rpm) and mixing of large volumes (up to 15 L).

The “Hot” warning light flashes when the hotplate surface reaches 50°C, and continues to flash until the surface temperature drops below 50°C, even when unplugged.

Hotplates and hotplate stirrers are available in glass-ceramic or coated metal tops; the square-shaped surfaces allow more flexibility of vessel sizes and combinations.

- Save Space: compact, stackable design for reduced footprint
- Safe: hot warning light remains on even when unplugged
- Protected: glazed with BioCote® for antimicrobial protection
- Control: Optional temperature controller available
- Robust: built with a tough aluminium casing for longevity
- Convenient: controller retort stand easily nests under unit
- Customisable: choice of surface material



**LAB704** Stuart US152 Undergrad Hotplate/Stirrer

**LAB704.1** Stuart UC152 Undergrad Hotplate/Stirrer

**LAB704.2** Stuart US152D Undergrad Digital Display Hotplate/Stirrer

**LAB704.3** Stuart UC152D Undergrad Digital Display Hotplate/Stirrer

**LAB705** Stuart US150 Undergrad Hotplate

**LAB705.1** Stuart UC150 Undergrad Hotplate

**LAB706** Stuart US151 Undergrad Stirrer

**LAB706.1** Stuart UC151 Undergrad Stirrer

Model	Plate Material	Heat Area	Heat Power	Max Temp	Stirrer Speed	Max Stir	Dimensions
US152	Coated Aluminium	150 x 150	700 w	325°C	100 2000rpm	15 L	180 x 255 x 122
US152D	Coated Aluminium	150 x 150	700 w	325°C	100 - 2000rpm	15 L	180 x 255 x 122
UC152	Glass Ceramic	120 x 120	500 w	450°C	100 - 2000rpm	15 L	180 x 255 x 122
UC152D	Glass Ceramic	120 x 120	500 w	450°C	100 - 2000rpm	15 L	180 x 255 x 122
US150	Coated Aluminium	150 x 150	700 w	325°C	-	-	180 x 255 x 122
UC150	Glass Ceramic	120 x 120	500 w	450°C	-	-	180 x 255 x 122
US151	Stainless Steel	-	-	-	100 - 2000rpm	15 L	180 x 255 x 109
UC151	Glass Ceramic	-	-	-	100 - 2000rpm	15 L	180 x 255 x 109



### Probe Holder

clamps on to the retort rod to allow secure positioning of the temperature probe in the sample.

### Retort Rod

securely screws in to the rear of all models of hotplates and hotplate stirrers.

### PTFE Probe

chemically-resistant probe for accurate monitoring of hazardous or corrosive samples.

## Stuart Temperature Controller

All hotplate models are compatible with the Stuart SCT2 temperature controller. Together with your Undergrad hotplate, the SCT2 ensures accurate temperature control of aqueous or oil based samples, up to a maximum of 200°C. The SCT2 controller is automatically detected when plugged in.

- Accurate liquid temperature control
- Built-in retort fitting & probe holder
- Detachable temperature probe
- Bright, easy to read LED display
- Compact & light weight
- Comprehensive range of accessories

The temperature of sample is precisely controlled at all times. A range of accessories are also available for the complete set-up of controllers, temperature probes and stirrer hotplates.

**LAB707** Stuart SCT2 Temperature Controller

**LAB707.1** Stuart SR1 Retort rod (600 x 12mm diam.)

**LAB707.2** Probe Holder for Temperature Controller

**LAB707.3** PTFE probe for Temperature Controller

## Advanced Digital Melting Point

Designed for fast, accurate determination of melting points, can take three samples simultaneously. To allow maximum flexibility a plateau facility is included with variable ramp rate between 0.5 and 10°C in 0.1°C increments.

- Large clear back lit alphanumeric LCD display
- Record up to 8 events in memory for each of the three tubes
- See both temperature and tubes through the unique viewport
- The head can be stored safely within the body of the unit
- Includes storage pre-prepared samples and capillary tubes
- Supplied with a calibration certificate showing individual serial numbers for traceability

- **Integrated Cooling:** 10 minutes (350°C–50°C)
- **Maximum Temperature:** 400°C
- **Time to Temp:** 6 mins (50–350°C)
- **Dimensions:** 325 x 200 x 170mm
- **Net Weight:** 3.6kg

LAB146 Advanced Digital Melting Point



## SMP50 Automatic Melting Point Apparatus

The latest camera technology is employed to produce a high resolution video of the sample melt, allows the melt algorithm to identify the smallest of changes in the sample, able to accurately determine the melt point of up to three samples simultaneously.

Operated via the 7" colour touchscreen. Once programmed, the SMP50 can complete the melt analysis independently, or the melt can also be observed on the screen live or post melt. During post melt review additional tags can be added, such as meniscus point or the automatically obtained result can be overwritten.

A generous 8GB on board storage is included, which should comfortably hold approximately 300 melts files including videos. Results can also be transferred via USB stick on to PC for a more permanent long term record. All video



files include a temperature stamp, so whatever device you view them on you can confirm the automatically obtained result.

The SMP50 features a useful storage drawer to house all standard capillary tubes. The drawer also contains a small glass cutter that can be used to accurately cut sample tubes in half, for those users who prefer not to use whole tubes.

While all measurement files can be easily transferred onto a PC you can choose the optional accessory printer for direct printing. All units are factory supplied with a calibration certificate showing individual serial number for traceability. The SMP50 also conforms to Pharmacopeia and GLP.

LAB210 SMP50 Automatic Melting Point Unit

LAB211 SMP50 Unit with IQ/OQ documentation

LAB212 Accessory Printer

LAB213 Glass Melting Point tubes - Closed at both ends 100pk

LAB214 Glass Melting Point tubes - Closed at one end 100pk

## Stuart Tube Roller Mixer

Provide a gentle, but efficient, rocking and rolling action. Four models are available. Two analogue with a fixed speed of 33rpm. Two digital models with digitally controlled speed of 5–60RPM and programmable timer. Your selection of either 6 or 9 rollers.

Feature easy to remove side panels, ensuring samples remain on the roller during continuous use. The rollers detach to hold larger vessels, suitable for a variety of different sized tubes and bottles.

Recommended for mixing blood samples, viscous substances and liquid-solid suspensions where minimum aeration is required. Can be used up to 60°C and humidity up to 80%, or down to 4°C.

- Designed for continuous quiet rocking and rolling action
- Removable side panels to keep tubes on the roller
- With BioCote antimicrobial protection

LAB123 Stuart Tube Roller Mixer SRT6

LAB124 Stuart Tube Roller Mixer SRT6D

LAB125 Stuart Tube Roller Mixer SRT9

LAB126 Stuart Tube Roller Mixer SRT9D

LAB126.1 Stacking System for Rollers - 4x Stack blocks

Model:	SRT6	SRT9	SRT6D	SRT9D
<b>Model Type:</b>	Analogue	Analogue	Digital	Digital
<b>Speed Range:</b>	33RPM	33RPM	5–60RPM	5–60RPM
<b>Amplitude:</b>	16mm	16mm	16mm	16mm
<b>Max Load:</b>	3Kg	3Kg	3Kg	3Kg
<b>Timer Included:</b>	No	No	Yes	Yes
<b>Roller Size (mm):</b>	340 x 30	340 x 30	340 x 30	340 x 30
<b>Net Size (mm):</b>	565 x 240 x 110	565 x 360 x 110	565 x 240 x 110	565 x 360 x 110
<b>Net Weight:</b>	5.1Kg	6.9Kg	5.1Kg	6.9Kg



## Stuart SD300/SD500 Digital Hotplates

Metal top plate gives very even plate temperature and uniform heating conditions. Hotplates with microprocessor control for accurate monitoring of the plate temperature. Large capacity to accommodate multiple vessels or microscope slides.

Model:	SD300	SD500
No. of Plate Positions:	600W	1500W
Platform Dimensions:	300 x 300mm	300 x 500mm
Unit Dimensions:	240 x 300 x 160mm	360 x 420 x 160mm
Weight:	6 Kg	12 Kg



LAB073 Stuart SD300 300x300mm

LAB074 Stuart SD500 300x500mm

## Aquatron® Deioniser ADH

The disposable ion exchange cartridges slowly change colour from green to blue as they are exhausted giving at a glance indication of the resin condition. No need for conductivity meters, batteries or mains electrical power. Supplied with flexible hose for connection to a tap and a stopcock to control flow rate.

Can be linked in series with the Aquatron® filter either by a flexible hose or the rigid coupling (ALC) available as an accessory. Ideal as a pre-treatment for Aquatron® water stills.

- Low cost disposable cartridges
- Free standing or wall mountable (See mounts below)

LAB227 Deioniser cartridge housing - Single capacity

LAB228 Deioniser cartridge housing - Double capacity



Housing and ion exchange cartridges must be ordered separately.

LAB229 Deioniser Cartridge - 55L Capacity (each)

LAB230 Wall bracket - Deioniser cartridge housing Single

LAB231 Wall bracket - Deioniser cartridge housing Double

## Techne Water Baths

Designed to be used with a clip-on Tempette or Tempunit® thermoregulator, with carrying handles for added safety. Stoved enamelled steel outer cases and are supplied with bridge mounting plate to hold the thermoregulator.

- Stainless steel construction with integrated handles
- Seam-free & corrosion resistant inners for easy cleaning
- Rugged splash-proof case
- Maximum working temperature of 200°C

Model:	B-8	B-12	B-18	B-26
Capacity:	8 Litres	12 Litres	18 Litres	26 Litres
(mm) Dimensions:	265 x 325 x 172	354 x 325 x 172	530 x 325 x 172	530 x 325 x 222
Max Work Depth:	130mm	130mm	130mm	180mm
Min Work Depth:	100mm	100mm	100mm	150mm
Max Work Capc.:	8 Litres	11.6 Litres	18 Litres	26 Litres
Max Work Depth:	6 Litres	8.4 Litres	13.2 Litres	10.5 Litres
Weight:	5.5Kg	6.1Kg	7.5Kg	9.5Kg

LAB151 B-8 Bath, 8 Litre Capacity

LAB152 B-12 Bath, 12 Litre Capacity

LAB153 B-18 Bath, 18 Litre Capacity

LAB154 B-26 Bath, 26 Litre Capacity

LAB155 Flat Lid for 8 Litre Bath

LAB156 Flat Lid for 12 Litre Bath

LAB157 Flat Lid for 18 or 26 Litre Bath



3 Year Warranty

## Techne TE-10D Thermoregulator

The Thermoregulator is designed to be used with the Techne® unheated water baths or any other suitable laboratory vessels. They will heat, circulate and safely control the temperature of the liquid in the bath within precise limits.

LAB158 TE-10D Thermoregulator including Clamp - Fits all models



## Stuart Digital Water Baths

Digital water baths with clear easy to read LED display of water temperature. Incorporated over temperature protection system that tracks the set temperature and controls the heater in the event of a fault.

The heater is mounted underneath the tank to allow easy cleaning. Includes low level water sensor which cuts power to prevent the bath boiling dry.

- Incorporated drain for easy emptying of the bath
- Static baths choice of sizes: 6, 15 or 24 Litres
- Digital display and selection of temperature
- Low level water sensor

Model:	SWB6D	SWB15D	SWB24D
Litre Capacity:	6L	15L	24L
Ext. Dimensions:	335 x 230 x 280mm	335 x 408 x 280mm	335 x 584 x 280mm
Int. Dimensions:	300 x 150 x 200mm	300 x 325 x 200mm	300 x 500 x 200mm
Heater Power:	350W	750W	1400W

A PCB lid is included, Stainless steel lids can be purchased.

**LAB117** Stuart SWB6D Digital Water Bath 6L

**LAB118** Stuart SWB15D Digital Water Bath 15L

**LAB119** Stuart SWB24D Digital Water Bath 24L

**LAB120** Stainless Steel Lid for 6L bath

**LAB121** Stainless Steel Lid for 15L bath

**LAB122** Stainless Steel Lid for 24L bath



## Dri-Block Heaters and Tubes

**Techne® Dri-Block® heaters have been providing a safe, dry, constant temperature source in the laboratory for 50 years.**

Now Techne® are proud to produce the Dri-Block® range offering market-leading choice, flexibility and specification.

Dri-Block® heaters are a source of precision temperature control for general heating and incubating applications as well as sensitive analytical procedures particularly suited to microbiology and clinical laboratories.



- Fascia and side-panels present a stylish appearance
- Selectable temperature units, °C or °F
- Integrated count-down timer, from 1m to 99h59m
- Audible alarm
- Improved venting, cool to touch even when the heater is at maximum temperature
- Widest choice of aluminium blocks available on the market

### Dri-Block Heaters

#### DB100/2 Dri-Block Heater

- 5 Character LCD Screen
- **Maximum blocks:** 2
- **Heater power:** 300W
- **Dimensions:** 202 x 260 x 105mm
- **Shipping weight:** 5kg



#### DB100/3 Dri-Block Heater

- 5 Character LCD Screen
- **Maximum blocks:** 3
- **Heater power:** 450W
- **Dimensions:** 279 x 260 x 105mm
- **Shipping weight:** 6kg



**LAB163** DB100/2 Dri-block heater 100°C - 2 blocks (230V)

**LAB163.1** DB200/2 Dri-block heater 200°C - 2 blocks (230V)

**LAB164** DB100/3 Dri-block heater 100°C - 3 blocks (230V)

**LAB164.1** DB200/3 Dri-block heater 200°C - 3 blocks (230V)

### Tube Inserts

Anodised aluminium alloy blocks provide excellent thermal conductivity. Most blocks have a separate hole to accommodate a thermometer if required.

Dri-Block heaters can accommodate block inserts in any combination (size-permitting). Depending on the combination of blocks selected, plastic spacers can be employed to fill a half-width recess, ensuring optimal thermal performance.



**LAB167** 0.2ml Microtubes

**LAB168** 0.5ml Microtubes

**LAB169** 1.5ml Microtubes

**LAB170** 2.0ml Microtubes

**LAB171** 6mm Wide Tubes

**LAB172** 10mm Wide Tubes

**LAB173** 12mm Wide Tubes

**LAB174** 15mm Wide Tubes

**LAB175** 19mm Wide Tubes

**LAB176** 23mm Wide Tubes

**LAB177** 25mm Wide Tubes

**LAB178** 50ml Centrifuge Tubes

## BL°CKICE Cooling Block

Ideal for chilling samples at sub-ambient temperatures. Holding two standard aluminium blocks from the Dri-Block®, offering fast cool down times to ensure the unit is quickly available for use.

The integrated timer allows up to 9 days to be programmed, the timer will not start until a stable temperature has been reached.

Features Isotemp® temperature control zone that ensures that all contents of the unit are kept at an even temperature.

**Unit is supplied without block inserts, purchased separately.**

- Maximum temperature range 0°C to 40°C\*
- Count up and count down timer
- Temperature displayed in °C or °F
- Buzzer indicates time has elapsed and temperature is reached
- Holds 2 aluminium insert blocks
- **Dimensions:** 190 x 240 x 225mm
- **Weight:** 3.0kg

*\*Please note: BL°CKICE will achieve any temperature between 4–37°C within 30 minutes in an ambient temperature of 20°C.*

*Can also reach 0°C or 40°C, but may take several hours. Reaching 0°C can be speeded up by pre-cooling the blocks before use.*



**LAB165** BL°CKICE Cooling Block

## N°ICE Electronic Ice Bucket

Ideal for chilling or incubating any number or size of tubes for long periods of time. Instead of floating tubes in melting ice, the N°ICE ceramic-coated beads maintain the temperature and support the sample vessels for as long as necessary.

Beads are chemically resistant and if required can be autoclaved at 134°C. As a time saving option, the bucket of beads can be incubated in the fridge overnight and used when needed.

Features Isotemp® temperature control zone that ensures that all contents of the unit are kept at an even temperature.

**N°ICE bucket & autoclaveable ceramic-coated beads included**

- Maximum temperature range 0°C to 40°C
- Temperature displayed in °C or °F
- Additional spare bucket and beads are available separately
- **Dimensions:** 190 x 240 x 225mm
- **Weight:** 4.5kg

*\* Please note: N°ICE will reach 4°C relatively quickly in an ambient temperature of 20°C, but may take several hours to reach 0°C.*

*Like an ice-bucket, the actual sample may not reach 0°C due to natural thermal transfer efficiency. Cooling can be sped up by pre-freezing the bucket and beads.*



**LAB166** N°ICE Electronic Ice Bucket

## PCRMax Alpha 1 Thermal Cycler

**These compact thermal cyclers deliver reproducible results every run—with little to no training needed.**

A Program Wizard generates a protocol specific to your sequence in seconds—a quick way to optimize new assays. Units also retain approximately 1000 reports for reviewing at a later date and run on an intuitive, HD Android™ tablet interface. Save your personal settings to your USB drive; sign in is as simple as inserting your USB drive, no password needed.

- Clear responsive touch screen
- Secure user-specific programming
- Adjustable heated lid and active sample cooling for sharper amplification.
- Flexible—your choice of 96-well or 384-well capacities
- Software allows quick access to commonly used protocols
- Min/Max Temperature: 10/100°C
- Temperature Accuracy: 50°C: ±0.25°C
- Min/Max Gradient: 1/29°C



**LAB179.1** Alpha 1 Thermal Cycler (Single 96-Well Capacity)

**LAB180.1** Alpha 1 Thermal Cycler (Single 384-Well Capacity)

## PCRMax Eco qPCR System

**Utilises patented block and optical technologies to deliver extreme speed, sensitivity and data quality.**

A high specification, economically priced real time thermal cycler that accommodates a unique 48-well polypropylene PCR plate utilizing the same geometry as standard 384-well plates, but only 1/8 of the size.

Comes with two distinct softwares: Eco Control, drives the unit's set up and experimental runs while Eco Study is the analysis package. Software is open license and can be used on any number of PCs. Data collection is monitored in real time, allowing researchers to access run viability immediately.

- Min. volume of 5 µl is validated, cutting reagent costs and making more efficient use of template DNA samples.
- HRM functionality as standard with the ability to discriminate class IV SNP >99% of the time
- Allows for simple multiplex analysis, up to four dyes at once
- World's most thermally accurate block gives consistent data
- High uniformity provides high quality data. Fast cycling enables several experiments per day, at an economical price
- Fastest block-based real-time PCR system: 40 cycles in 40 minutes as standard and 40 cycles in as little as 15 minutes after optimisation of temperatures and hold times
- Open platform, utilise any chemistry, dye or PCR reagent
- Easy to use software, making analysis simple and fast
- ECO 48 thermal technology



**LAB181.1** PCRMax Eco 48 Real-Time qPCR System

## BT Dry Block Heaters

convenient digitally controlled dry block heating system for rapid and precise heating. With a range of models available depending upon your requirements:

### BTD High temperature digital heater

- Heating range ambient + 5°C to 100°C
- Stability  $\pm 0.1^\circ\text{C}$ , uniformity  $\pm 0.2^\circ\text{C}$
- Holds combinations of four microtube sizes simultaneously
- Convenient integral timer for time-sensitive incubations
- 2-line display for precise setting of temperature/time

### BT5D High temperature digital heater

- Temperature range ambient plus 10 to 400°C
- Stability  $\pm 0.5^\circ\text{C}$ , uniformity 1%
- Timed or continuous operation
- Two models with different block capacities (16/26mm)



LAB331



LAB332

**LAB331** BTD Digital dry block heater (fixed block for Microtubes)

**LAB332** BT5D High temp. heater (fixed block for 16mm test tubes)

**LAB333** BT5D-26 High temp. heater (fixed block for 26mm test tubes)

## ES Shaker/Incubators

Versatile programmable bench-top shaker-incubators for mixing and incubating bio fluids, samples, cell cultures and tissues.

- Digital control of time, temperature and shaking speed
- Interchangeable platforms for shaking/incubating
- Equipped with direct drive shaking system for long-term use
- Simple to programme time, temperature and shaking speed

### ES-20 Shaker

- Variable speed: 50 to 250 rpm
- Temperature range: 25 to 42°C
- Load up to 8 kg

### ES-80 Shaker

- Variable speed: 50 to 250 rpm
- Temperature range: 25 to 80°C
- Load up to 2.5 kg



LAB341



LAB341

**LAB341** ES-20 Compact Shaker-Incubator (50-250 rpm, 25-42°C)

**LAB342** ES-80 Shaker-Incubator (50-250 rpm, 25-80°C)

## UV Cabinet/PCR Workstations

General purpose stainless steel PCR UV cabinet workstation with glass viewing panel for carrying out short-term procedures.

These cabinets are equipped with an open UV lamp installed in the upper part of the hood. UV-radiation from these lamps effectively disinfects the working area chamber, inactivating DNA / RNA fragments during 15-30 mins exposure.

Designed for robustness and ease of access, it features a built-in UV cleaner-recirculator

Equipped with a high efficiency flow-type bactericidal UV cleaner-recirculator which provide constant decontamination inside the cabinet during operation. The UV cleaner-recirculator consists of UV lamp, dust filters and a fan increasing the maximum density of the UV light making it sufficiently effective for DNA / RNA inactivation.

See specifications below or contact us for further details

LAB320



LAB323

Code	Model	Dimensions (mm)	Work Area (mm)	UV Lamp	UV Recirculator	Internal
LAB320	UVT-S-AR UK	585 x 585 x 1245	1200 x 520	2x 30w	1x 30w	3x Power Points
LAB321	UVT-B-AR UK	690 x 585 x 555	650 x 475	1x 25w	1x 25w	1x Power Point
LAB322	UVT-B-AR UK	690 x 585 x 555	650 x 475	1x 25w	1x 25w	—
LAB323	UVC/T-M-AR UK	535 x 515 x 690	650 x 475	1x 25w	1x 25w	—
LAB324	UVC/T-M-AR SKT UK	535 x 515 x 690	650 x 475	1x 25w	1x 25w	1x Power Point

## Prestige Medical Advance Lab

The Advance Lab has been specifically designed and developed for the laboratory market for the application of sterilising liquid media loads. The Lab autoclave has the additional benefit of operating as a standard apparatus or instrument steam steriliser.

Every unit is assembled and tested rigorously to ensure a high quality product at Prestige Medical's headquarters in Blackburn England.

The Lab autoclave has been designed to be robust and easy to maintain with a unique low cost external media probe, which has been designed to be a consumable item allowing it to be easily replaced by the end user.

- Integrated stainless steel waste tank
- Integrated data capture system (sd card)
- User friendly interface
- Visual status indicator
- Remote media probe with easy replacement technology
- FlexiRack system allows configuration of internal racking to specific load requirement, up to 20 different positions.
- Small footprint.
- Pressure die cast door with stainless steel reinforced Teflon coating, easy change gasket system and stainless steel door surrounds.
- Remote waste water connection for direct drain applications
- Remote water feed for direct feed from a suitable RO system
- HTS heat transfer system improves reduces load warm up times due to a direct connection with the heater.
- Media warming function 40oC - 60 oC
- RS232 connectivity port



**LAB216** Advance Lab 16L with integrated data logger

**LAB217** Advance Lab 22L with integrated data logger

## Prestige Medical Classic Media

### The appliance for science, for a safer laboratory

If you need to sterilize liquids and media or eliminate the risk of cross infection through contaminated waste, then the Classic Media autoclave offers a professional, safe and affordable solution.

If your facility uses a domestic pressure cooker for sterilization then this can represent a serious risk if used incorrectly. The Classic Media removes these risks, ensuring that you are protected from the risk of injury and have guaranteed sterilization.

- Eliminates the risk of super-heated vessels exploding
- Ensures expensive glassware is protected during the controlled cooling process which means liquids won't leak out
- Prevents the escape of gas or vapour
- Removes the potential of accidental overbalance whilst sterilizing.
- Load your equipment into one of the special baskets, set the programme with the one-touch button and you can relax with no need for constant supervision giving you more productive time in the laboratory.
- Special in-built software ensures exact temperatures are reached for the correct duration, every time.
- Priced to appeal to those on the tightest budget
- Two sizes – ideal for a variety of laboratory processes
- Lightweight and portable for maximum flexibility in use, the Classic Media fits on the smallest work bench
- Easy to operate and uses a standard 13 amp/240 volt power supply



**LAB218** Classic Media 9L

**LAB219** Classic Media 12L

**LAB220** TST Strips 126C (10 Min) - 50 Strips

## Classic Incubator (up to 70°C)



Offers a selection of highly efficient, reliable and cost effective units to suit most biological analysis, research and general lab applications. The simple thermostat system is easy to use and the units can be built up to meet individual requirements.



The control system comprises of a direct reading thermostat and overheat thermostat, both with calibrated scales and tamper proof locks. They also include a mains switch with indicator and heat and overheat indicators.

- Selection of sizes from 6 to 100L
- Exterior construction: sheet steel with an easy clean paint.
- Select interior chamber material: mild steel coated with aluminium (CLAD) or a stainless steel (SS) chamber.
- With/without a circulation fan (30+ litre models)
- Ambient temp. range: +5°C to 70°C (+8°C to 70°C with fan)
- Fluctuation +/- 0.25°C @ 37°C
- Fitted with fixed shelf runners and removable chrome plated wire grid shelves.
- The incubators have an insulated door as standard.
- Thermostatic control and independent overheat thermostat

### CLAD Interior Incubators

Litres	Int. Dimensions	Shelf/Pos.
6	15 x 23 x 19cm	1..1
18	26 x 26 x 27cm	2..2
30	24 x 36 x 35cm	2..2
40	32 x 36 x 35cm	2..3
50	33 x 49 x 33cm	2..3
75	33 x 49 x 45cm	2..3
100	45 x 49 x 45cm	3..4

Code	with Fan
LAB343	N/A
LAB344	N/A
LAB345	LAB350
LAB346	LAB351
LAB347	LAB352
LAB348	LAB353
LAB349	LAB354

### S/S Interior Incubators

Code	with Fan
LAB343	N/A
LAB344	N/A
LAB345	LAB350
LAB346	LAB351
LAB347	LAB352
LAB348	LAB353
LAB349	LAB354

## Base-Mounted Benchtop Incubator (up to 70°C)



### BASE MOUNTING VERSION

A range of highly efficient, reliable and cost effective units to suit most biological analysis, research and general laboratory applications. Featuring intuitive touch screen controls and excellent accuracies designed for industrial and lab incubators.

The control system comprises of a bespoke touch screen interface that offers both accurate temperature control and an integral overheat system using 2 individual Pt100 sensors. Advanced features can be turned on and off to suit bespoke heating applications and tailored to customer preference. Oven trending is displayed for up to 48 hours and optional upgrades are available for alarm outputs.

- Selection of sizes from 6 to 200L
- Exterior construction: sheet steel with an easy clean paint.
- Select interior chamber material: mild steel coated with aluminium (CLAD) or a stainless steel (SS) chamber.
- With/without a circulation fan (30+ litre models)
- On screen historical trending (48 hr)
- Temp range ambient: +5°C to 70°C
- Fluctuation +/- 0.25 °C @ 37 °C
- High resolution: 0.1°C
- Manual/Auto overheat reset
- Low chamber uniformity
- Touch screen interface
- C.E. compliant



### CLAD Interior Incubators

Litres	Int. Dimensions	Shelf/Pos.
6	15 x 23 x 19cm	1..1
18	26 x 26 x 27cm	2..2
30	24 x 36 x 35cm	2..2
40	32 x 36 x 35cm	2..3
50	33 x 49 x 33cm	2..3
75	33 x 49 x 45cm	2..3
100	45 x 49 x 45cm	3..4
125	55 x 49 x 45cm	3..5
150	55 x 49 x 53cm	3..5
200	75 x 49 x 49cm	4..7

Code	with Fan
LAB367	N/A
LAB368	N/A
LAB369	LAB376
LAB370	LAB377
LAB371	LAB378
LAB372	LAB379
LAB373	LAB380
LAB374	LAB381
LAB375	LAB382
N/A	LAB383

### S/S Interior Incubators

Code	with Fan
LAB384	N/A
LAB385	N/A
LAB386	LAB393
LAB387	LAB394
LAB388	LAB395
LAB389	LAB396
LAB390	LAB397
LAB391	LAB398
LAB392	LAB399
N/A	LAB400

## Side-Mounted Benchtop Incubator (up to 70°C)



### SIDE MOUNTING VERSION

Continuing the range, this model offers variation with controls mounted at the side of the unit to better suit requirements.

Select from your choice of CLAD or Stainless Steel interior construction and option to include fan assisted circulation.

- Selection of sizes from 50 to 200L
- Exterior construction: sheet steel with an easy clean paint.
- See previous product listing for full specification

#### CLAD Interior Incubators

Litres	Int. Dimensions	Shelf/Pos.
50	42 x 40 x 35cm	2.3
75	42 x 53 x 35cm	2.3
100	42 x 53 x 40cm	3.4
125	52 x 53 x 46cm	3.5
150	52 x 53 x 54cm	3.5
200	75 x 49 x 54cm	4..7

Code		with Fan	
LAB401		LAB406	
LAB402		LAB407	
LAB403		LAB408	
LAB404		LAB409	
LAB405		LAB410	
N/A		LAB411	

#### S/S Interior Incubators

Code		with Fan	
LAB412		LAB417	
LAB413		LAB418	
LAB414		LAB419	
LAB415		LAB420	
LAB416		LAB421	
N/A		LAB422	

## Large Capacity Incubator (up to 70°C)

Highly efficient, reliable and cost effective units. Suitable for larger applications of incubation, research and general lab applications. **Single or twin door designs.**

Bespoke touch screen interface that offers both accurate temperature control and an integral overheat system by using 2 individual Pt100 sensors. Advanced features can be turned on/off to suit bespoke heating applications and tailored to customer preference. Oven trending is displayed for up to 48 hours and optional upgrades are available for alarm outputs



2 Year Warranty

- Selection of sizes: 250 to 1250 litres
- Temperature range: ambient + 8 to 70°C
- Fluctuation +/-0.25°C @ 37°C
- Resolution 0.1°C
- On screen historical trending (48 hours)
- 8 Stage profile control
- 24/7 real time clock operation with count-down timer
- Manual or automatic overheat reset

#### Twin Door



Litres	Int. Dimensions	Shelf/Pos.
250	54 x 92 x 44cm	3.4
350	54 x 92 x 64cm	3.4
425	76 x 92 x 64cm	4.5
500	91 x 92 x 64cm	5.7
650	91 x 92 x 77cm	5.7
750	106 x 92 x 77cm	5.8
850	122 x 92 x 77cm	5.9
1000	142 x 92 x 77cm	5.11
1250	142 x 122 x 74cm	5.11

#### Standard Interior

Code	
LAB442	
LAB443	
LAB444	
LAB445	
LAB446	
LAB447	
LAB448	
LAB449	
LAB450	

#### S/S Interior

Code	
LAB451	
LAB452	
LAB453	
LAB454	
LAB455	
LAB456	
LAB457	
LAB458	
LAB459	

#### Single Door



Litres	Int. Dimensions	Shelf/Pos.
250	91 x 51 x 52cm	5.7
350	91 x 61 x 62cm	5.7
425	91 x 61 x 77cm	5.7
500	114 x 61 x 77cm	5.9
650	114 x 77 x 77cm	5.9
750	128 x 77 x 77cm	5.10
850	142 x 77 x 77cm	5.11
1000	142 x 77 x 92cm	5.11

#### Standard Interior

Code	
LAB460	
LAB461	
LAB462	
LAB463	
LAB464	
LAB465	
LAB466	
LAB467	

#### S/S Interior

Code	
LAB468	
LAB469	
LAB470	
LAB471	
LAB472	
LAB473	
LAB474	
LAB475	

## Classic General Oven (up to 250°C)



Classic Range of ovens offers a selection of highly efficient, reliable and cost effective units to suit most drying, warming and general laboratory applications. The simple to use thermostat system is good for teaching purposes and the units can be built up to meet individual requirements.

The exterior is constructed from sheet steel finished in an easy clean powder coated paint. The interior chamber is made from mild steel coated with aluminium (CLAD) with a stainless steel (SS) chamber available as an option. Fitted with fixed shelf runners and removable chrome plated wire grid shelves.

- Selection of sizes from 6 to 100L
- Temp range 40 °C to 250 °C
- Fluctuation +/- 0.75 °C
- Easy to use thermostatic control
- Independent overheat thermostat
- Easy clean powder coated body



B

Laboratory

### CLAD Interior Incubators

Litres	Int. Dimensions	Shelf/Pos.
6	15 x 23 x 19cm	1..1
18	26 x 26 x 27cm	2..2
30	24 x 36 x 35cm	2..2
40	32 x 36 x 35cm	2..3
50	33 x 49 x 33cm	2..3
75	33 x 49 x 45cm	2..3
100	45 x 49 x 45cm	3..4

Code	with Fan
LAB493	N/A
LAB494	N/A
LAB495	LAB500
LAB496	LAB501
LAB497	LAB502
LAB498	LAB503
LAB499	LAB504

### S/S Interior Incubators

Code	with Fan
LAB505	N/A
LAB506	N/A
LAB507	LAB512
LAB508	LAB513
LAB509	LAB514
LAB510	LAB515
LAB511	LAB516

## Base-Mounted Benchtop Oven (up to 250°C)



### BASE MOUNTING VERSION

highly efficient, reliable and cost effective ovens to suit most warming, drying and heat treatment processes. Available in a variety of sizes and designed with both side or base mounted displays to suit your exact needs. Featuring our latest touch screen control system which offers intuitive control and excellent accuracies designed for industrial and laboratory ovens.

comprises of a bespoke touch screen interface that offers both accurate temperature control and an integral overheat system using 2 individual Pt100 sensors. Advanced features can be turned on and off to suit bespoke heating applications and tailored to customer preference. Oven trending is displayed for up to 48 hours and optional upgrades are available for alarm outputs

- Selection of sizes from 6 to 200L
- Select interior chamber material: mild steel coated with aluminium (CLAD) or a stainless steel (SS) chamber.
- On screen historical trending (48 hours)
- High accuracy Pt100B duplex sensors <math>< 0.8^{\circ}\text{C}</math>
- Excellent stability <math>< \pm 0.6^{\circ}\text{C}</math> (fan assisted)
- Energy efficient with integral energy meter
- Manual or automatic overheat reset
- Low chamber uniformity
- With/without a circulation fan
- Temp range 40°C to 250°C
- New set point lock feature



### CLAD Interior Incubators

Litres	Int. Dimensions	Shelf/Pos.
6	15 x 23 x 19cm	1..1
18	26 x 26 x 27cm	2..2
30	24 x 36 x 35cm	2..2
40	32 x 36 x 35cm	2..3
50	33 x 49 x 33cm	2..3
75	33 x 49 x 45cm	2..3
100	45 x 49 x 45cm	3..4
125	55 x 49 x 45cm	3..5
150	55 x 49 x 53cm	3..5
200	75 x 49 x 49cm	4..7

Code	with Fan
LAB517	N/A
LAB518	N/A
LAB519	LAB526
LAB520	LAB527
LAB521	LAB528
LAB522	LAB529
LAB523	LAB530
LAB524	LAB531
LAB525	LAB532
N/A	LAB533

### S/S Interior Incubators

Code	with Fan
LAB534	N/A
LAB535	N/A
LAB536	LAB543
LAB537	LAB544
LAB538	LAB545
LAB539	LAB546
LAB540	LAB547
LAB541	LAB548
LAB542	LAB549
N/A	LAB550

## Prime XL Large Capacity Oven (up to 250°C)



the flagship brand of Genlab Large Capacity Ovens. These are built to the highest standards and packed with features and enhancements. Heavy duty stainless steel interior, increased accuracies and quicker responding.

Built around a heavy duty panelled framework, we can offer increased load capabilities in the range, multiple reinforced shelves and operate at 300°C continuously. They feature our latest touch screen control system.

- **Your choice of single or twin door design**
- Temperature range: 50°C to 250°C
- On screen historical trending (48hours)
- 8 stage profile control
- 24/7 real time clock operation and count down timer
- Manual or automatic overheat reset
- High accuracy Pt100A duplex sensors <0.6°C
- Fan assisted circulation
- Excellent stability <+/- 0.8°C
- Quick responding and Audible warnings

### Twin Door

Litres	Int. Dimensions	Shelf/Pos.	Code	
250	54 x 92 x 44cm	3..4	LAB619	
350	54 x 92 x 64cm	3..4	LAB620	
425	76 x 92 x 64cm	4..5	LAB621	
500	91 x 92 x 64cm	5..7	LAB622	
650	91 x 92 x 77cm	5..7	LAB623	
750	106 x 92 x 77cm	5..8	LAB624	
850	122 x 92 x 77cm	5..9	LAB625	
1000	142 x 92 x 77cm	5..11	LAB626	
1250	142 x 122 x 74cm	5..11	LAB627	

### Single Door

Litres	Int. Dimensions	Shelf/Pos.	Code	
250	91 x 51 x 52cm	3..4	LAB628	
350	91 x 61 x 62cm	3..4	LAB629	
425	91 x 61 x 77cm	4..5	LAB630	
500	114 x 61 x 77cm	5..7	LAB631	
650	114 x 77 x 77cm	5..7	LAB632	
750	128 x 77 x 77cm	5..8	LAB633	
850	142 x 77 x 77cm	5..9	LAB634	
1000	142 x 77 x 92cm	5..11	LAB635	



## Labcold Sparkfree Refrigerators

The Sparkfree Refrigerator range is engineered to store flammable materials safely with no sources of ignition inside the chambers.

Everything that could cause a spark, is located outside of the refrigerator chamber for safety. Designed specifically for laboratories, these fridges come in a range of sizes.

For extra security all sparkfree models are fitted with a built in lock and digital temperature display. The display features high and low audio and visual temperature alarms as standard in addition to a door open alarm.

Available in a range of sizes to suit your requirements with accessories if required.

- Temperature Display
- Low/High Temperature and Door open alarms
- Sparkfree safety interior
- Off Cycle Automatic defrosting
- Door Locks Included
- Range of sizes available
- 2 Year warranty
- **Power Requirement:** 220/240V 50Hz



HRF283



HRF338



HRF279



Code	Size	Dimensions (mm)	Access Port	
HRF338	66L	740 x 450 x 510	No	
HRF283	150L	835 x 600 x 600	Yes	
HRF279	439L	1875 x 600 x 700	Yes	



## Labcold Upright Sparkfree Freezers

These freezers are engineered to store flammable materials safely with all potential sources of ignition, such as the thermostat removed from inside the compartments of both the fridge and the freezer.

For extra security all sparkfree models are fitted with a built in lock and digital temperature display.

- Temperature display and door locks fitted as standard
- Door Open Alarm Fitted
- Sparkfree Safety Interior
- **Temperature Range:** -18°C to -23°C
- **Power Requirement:** 220/240V 50Hz



HRF339

HRF223



HRF227

Code	Capacity	Product Type	Dimensions	No. of Shelves	Access Ports
HRF339	66 Litre	Bench Top	740 x 450 x 510mm	3	No
HRF223	124 Litre	Under Bench	835 x 600 x 600mm	3	Yes
HRF227	406 Litre	Upright	1875 x 600 x 700mm	6	Yes

## Labcold Sparkfree Fridge Freezers

These fridge freezers are engineered to store flammable materials safely with all potential sources of ignition, such as the thermostat removed from inside the compartments of both the fridge and the freezer.

Customisable to meet your requirements, digital temperature displays, temperature alarms and temperature recording can be added if required.

- 271L (fridge) & 113L (freezer) Sections
- Automatic defrosting in fridge and Drawers in Freezer
- CFC and HCFC free
- Completely Sparkfree
- **Fridge Temp Range:** +2°C to +10°C
- **Freezer Temp Range:** -18°C to -23°C
- **Power Requirement:** 220/240V 50Hz



HRF356



HRF355

Code	Dimensions	Door Locks
HRF355.1	2000 x 625 x 680mm	No
HRF356.1	2000 x 625 x 680mm	Yes

## Labcold ITV Icemakers

Labcold ITV ice makers come in two versions: One that produces ice cubes (cylindrical) and one producing crushed ice. Both varieties produce hygienic, clear, pure ice ideal for medical and laboratory applications.

Featuring a lime scale reducing spray system and a simple and efficient paddle mechanism these Ice Makers require both a water and electricity supply and a floor level drain.

- Limescale reducing spray system
- Simple and efficient paddle mechanism
- Designed to require little maintenance
- Stainless Steel Exterior
- **Power Requirement:** 220/240V 50Hz

Ice Cubes



Crushed Ice



Ice Cube Makers:

Code	Ice Per Day	Size (mm)
HRF228	20Kg	730 x 405 x 515
HRF229	35Kg	885 x 465 x 595
HRF230	81Kg	1035 x 715 595
HRF231	150Kg	1140 x 860 x 700

Crushed Ice Makers:

Code	Ice Per Day	Size (mm)
HRF232	66Kg	830 x 405 x 515
HRF233	90Kg	870 x 465 x 595
HRF234	156Kg	1435 x 515 x 550
HRF235	234Kg	1635 x 685 x 550

ACCOSON



## Accoson AC200 LED Examination Light

Compact head design offers ease of access to power control combined with a fully-flexible neck which remains in stable once positioned.

Bright LED illumination requires no bulb replacements and consume far less energy. This examination light provides high colour rendering whilst still offering a comfortable setting for the patient.

- Colour temperature: 5,000°K
- IRC: >95
- Luminous intensity: 1m - 11,000 lux
- Average life LEDs: 50,000 hours
- Light angle: 6th
- Field diameter at 1m: 12cm
- Power: 10W
- Voltage: 95-240V / 50-60Hz
- Thermal protector: Yes

**HCL028** AC200 Wall Mount with Flexible Arm

**HCL028.1** AC200 Desk Mount with Flexible Arm

**HCL028.2** AC200 Mobile Base with Flexible Arm

## Accoson AC300 LED Examination Light

Designed with ease of use this range with flex and articulated arm offer complete freedom of movement allowing for accurate light placement, which is quickly adapted when required. Clinicians can easily adjust the light intensity through the simple touch panel controls.

Bright LED illumination requires no bulb replacements and consume far less energy. This light provides high colour rendering whilst offering a comfortable setting for the patient.

- Colour temperature: 5,000°K
- IRC: >96
- Luminous intensity at typical working distances:
  - at 1m - 35,000 lux
  - at 0.8m - 45,000 lux
  - at 0.5m - 65,000lux
- Average life of LEDs: 50,000 hours
- Light angle: 4th
- Field diameter at 1m: 10cm
- Power: 7W
- Voltage: 95-240V / 50-60Hz
- Thermal protector: Yes

**HCL029** AC300 Wall Mount with Flexible Arm

**HCL029.1** AC300 Desk Mount with Flexible Arm

**HCL029.2** AC300 Mobile Base with Flexible Arm

**HCL030** AC300 Wall Mount with Spring Arm

**HCL030.1** AC300 Desk Mount with Spring Arm

**HCL030.2** AC300 Mobile Base with Spring Arm

ACCOSON



## Welch Allyn® Green Series™

The Welch Allyn® Green Series™ LED lights provide bright, white light for accurate skin colour and improved examinations. What's more they provide a 50,000 hour life and consume considerably less energy.

These LED lights require no bulb replacements and no heat dissipation for greater safety and lower running costs.

The hygienic touchless On/Off buttons help to reduce the risk of infection transfer or cross contamination, providing greater peace of mind for patient and practitioner.

Each light is highly robust and has multiple mounting options available. Options for attaching to a wall, table, ceiling or convenient roll stand provide flexibility.

### Welch Allyn® GS300

A single white, bright LED that does not require replacement, the GS300 Exam Light provides a whiter, brighter light than halogen and consumes less energy for improved facility efficiencies

Now you can see true tissue colour rendition while reducing your current cost of ownership. The Green Series Lights were designed to improve patient exams while reducing environmental impact.

- One intense LED light
- Perfect for small practices & clinics
- 20,000 lux light intensity (at normal working distance)
- 79cm flexible arm length
- 5 year limited warranty

**HCL325** GS300 Table/Wall Mounted Light

**HCL326** GS300 Mobile Light



### Welch Allyn® GS600

Designed specifically for demanding viewing conditions, with the ability to control the light output, the Green Series 600 Minor Procedure Light features three, white LEDs in a wider head with integrated handle for easy maneuverability.

- Three intense LED lights with two brightness settings
- Easily manoeuvrable head
- 50,000 lux light intensity (normal working distance)
- 79cm flexible arm length
- 5 year limited warranty

**HCL327** GS600 Wall/Desk Light

**HCL328** GS600 Mobile Light

### Welch Allyn® GSIV

Perfect for specialties that require very focused light in specific areas, the GSIV Light provides you with 3x the typical light output and features a highly flexible pipe that is twice as long as conventional pipes. With a compact, unobtrusive head, it ensures pinpoint accuracy and true tissue colour rendition.

- Light Source 1 White LED
- Colour Temperature 5,500°K
- 20,000 Lux Light Intensity (normal working distance)
- LED Life 50,000 hours
- Working Distance 40cm
- Spot Size at Working Distance 10-25cm
- 126cm flexible arm length

**HEL222** GSIV Examination Light Wall/Desk

**HEL221** GSIV Examination Light Mobile



## DARAY® X1 Series Examination Lights

The DARAY X100 examination light is the perfect choice for value and performance. This examination light has a flexible gooseneck, remains stationary once positioned. The clinician can easily turn the examination light off and on.

LED's (light emitting diodes) have been around for a long time. Recently this technology has become leading-edge in the field of lighting – a breakthrough technological solution to the inherent problems of the incandescent light bulb.

We have taken the technology and developed it further to provide high definition lighting solutions with no infrared, high brightness, low environmental impact, low power consumption, no toxic chemicals and a long operating life.

- **Updated design** – Now with 320° head rotation
- **New aluminium head with improved performance**
- Infection controlling design
- Low total cost of ownership
- 12,000 lux intensity ±500 @ 0.5m
- 4,200K colour temperature



**DARAY**  
Medical

5 Year Warranty

<b>HCL385</b>	Wall mounted light with flexible arm
<b>HCL386</b>	Rail clamp light with flexible arm
<b>HCL387</b>	Desk mounted light with flexible arm
<b>HCL388</b>	Weighted desk stand light with flexible arm
<b>HCL389</b>	Mobile light with flexible arm
<b>HCL390</b>	1m Rail with Wall Fixings

## DARAY® X2 Series Examination Lights

The X2 Series from DARAY® is designed for use during medical consultation and diagnosis.

Utilising LED technology, the X2 series costs up to 75% less to run than conventional equivalent halogen lights and has a lamp life of around 50,000 hours.

The re-designed BioProtect light-head is now fully enclosed assisting in management of infection control. With 32,000 lux at 0.5m and various mounting options to suit your application, the X2 series is the perfect choice for your examination needs.

- Less heat making it more comfortable for users
- Smooth, BioProtect fully enclosed light-head to assist in the management of infection control
- Low maintenance
- 32,000 lux @ 0.5m
- Long lamp life - 50,000 hrs
- Colour temperature of 4,200k
- Variable intensity and multiple mountings available
- Bioprotect on all painted finishes

**DARAY**  
Medical

### DARAY® X200 Examination LED Light



5 Year Warranty

<b>HCL395</b>	X200 Mobile light with 3m cable
<b>HCL391</b>	X200 Wall mounted light with plug-top power supply
<b>HCL392</b>	X200 Rail clamp light with plug-top power supply
<b>HCL393</b>	X200 Desk mounted light with plug-top power supply
<b>HCL394</b>	X200 Weighted desk stand light with plug-top power supply
<b>HCL394.1</b>	X200 Fixed Desk Mount Light
<b>HCL395</b>	X210 Wall mounted light (IEC plug)
<b>HCL397</b>	X210 Wall mounted – For qualified electrician install only
<b>HCL397.1</b>	X210 Rail Clamp Light with IEC Cable/Curled IEC
<b>HCL390</b>	1m Rail with Wall Fixings

### DARAY® X240 Examination LED Light



5 Year Warranty

<b>HCL442</b>	X240 Mobile Light with 3m cable
<b>HCL439</b>	X240 Wall Mount Light with plug-top power supply
<b>HCL440</b>	X240 Rail Clamp Light with plug-top power supply
<b>HCL441</b>	X240 Desk Clamp Light with plug-top power supply
<b>HCL525</b>	X240 Weighted desk stand light with plug-top power supply
<b>HCL526</b>	X240 Fixed Desk Mount Light
<b>HCL442</b>	X240 Mobile Light with 3m cable
<b>HCL527</b>	Hardwired W3 BESA Wall Mount Light
<b>HCL528</b>	Hardwired W4 Spreader Plate Wall Mount Light
<b>HCL529</b>	Hardwired W5 Cableflow Trunking Mount Light
<b>HCL530</b>	Hardwired W6 Spreader Wall Mount Light + Transformer

## DARAY® X400LFM Examination Light

A high-quality; efficient LED examination light offering the versatility of a mobile base with a flexible head mounting.

Being the ideal size it can be positioned quickly and accurately, remaining stable throughout. The light-head gives a high-intensity output (120,000 lux at 0.5m) with no heat in the beam to ensure patient comfort.

Infection control is easily managed by the application of BioProtect® antimicrobial protection. The X400LFM gives you maximum flexibility where you need it.

- Specifically designed for gynaecological examinations
- DARAY® LED lights cost up to 75% less to run than conventional equivalent halogen lights
- Low temperature beam making it more comfortable for users
- Smooth, BioProtect fully enclosed light-head to assist in the management of infection control
- Low maintenance
- Long lamp life – 50,000 hours
- 4,200k colour temperature
- Variable intensity
- DARAY® LED lights are more robust than conventional equivalent halogen lights
- BioProtect on all painted finishes
- Increased intensity, 0–120,000 lux @ 0.5m



With telescopic reach

**DARAY**  
Medical



**HCL330** Mobile with Gooseneck and Up-stand

**DARAY**  
Medical



## DARAY® X3 Series Examination Lights

The DARAY® X3 series of examination lights have a smooth, spring balanced arm and a telescopic ceiling tube making the light extremely versatile, perfect for gynaecological procedures.

Utilising LED technology, this general examination light has been developed to provide an intense beam with excellent colour rendering properties.

With a low total cost of ownership, costing up to 75% less to run than equivalent halogen lights. This light has around 50,000 hours of life from the LED light engine equating to around 25 years of clinical use.

Requires minimal maintenance and has a smooth, fully enclosed BioProtect® head to assist with the management of infection control. This is an ideal light for GP surgeries and clinics where flexibility and performance are crucial.

- Strong beam of light with an even intensity across the entire area for clearer viewing and reduced eye strain
- 50,000 hours of life from the LED light engine - that's over 25 years of normal clinical use
- Costs up to 75% less to run than halogen
- One touch variable intensity
- Telescopic ceiling tube - extremely versatile
- Balanced arm with excellent range of movement
- 1000mm reach - ideal for gynaecological examinations
- No bulb changes - reduces waste by 95% over its lifetime
- **Light intensity @ 0.5m** - 64,000 lux
- **Light intensity @ 0.75m** - 30,000 lux
- **Light intensity @ 1m** - 17,000 lux
- **Colour temperature** - 4,300K

**HCL436** Ceiling Mount Light

**HCL437** Wall Mount Light

**HCL438** Mobile Mount Light

**HCL531** Rail Clamp Light

**HCL532** Desk Clamp Light

**HCL397** Desk Stand Light

**HCL534** Fixed Desk Mount Light

**HCL438.1** X3 24V Battery Back-up

**HCL535** Hardwired W3 BESA Wall Mount Light

**HCL536** Hardwired W4 Spreader Plate Wall Mount Light

**HCL537** Hardwired W5 Bracket + Plate Trunking Mount Light

**HCL538** Hardwired W6 Spreader Wall Mount Light + Transformer

## DARAY® X4 Series Examination Lights

The DARAY® X400 is a premium quality LED examination light for use in all general medical diagnosis and procedures.

A large diameter light-patch gives excellent illumination and variable intensity for extra functionality along with a redesigned light-head providing increased efficiency.

- Improved efficiency, DARAY® LED lights cost up to 75% less to run than conventional equivalent halogen lights
- Low temperature beam making it more comfortable for clinician and patient
- Smooth, fully enclosed BioProtect head to assist in the management of infection control
- Low maintenance
- Long lamp life - 50,000 hours
- Colour temperature of 4,200k
- DARAY® LED lights are more robust than conventional equivalent halogen lights
- Battery back option available
- Increased light intensity of 120,000 lux @ 0.5m
- 320° head rotation

**HCL398** Ceiling mounted light

**HCL399** Wall mounted light

**HCL400** Mobile mounted light

**HCL382** Ceiling mount cover (Required for conventional ceilings)



## DARAY® X7 Series Examination Lights

**Both powerful and flexible, with variable colour adjustment.**

Available with a wide range of mount options to ensure your light is exactly where you need it. Utilising LED technology, this general examination light has been developed to provide an intense beam with excellent colour rendering properties.

Has a low total cost of ownership, costing up to 75% less to run than equivalent halogen lights. This light has around 50,000 hours of life from the LED light engine equating to around 25 years of clinical use. The X7 requires minimal maintenance.

- Light intensity (Lux) @ 0.5m 50,000 Lux
- Light Intensity (Lux) @ 1m 22,500 Lux
- Colour Temperature 3,600 - 5,000K (±500K)
- Colour Rendering Index Ra - 95, R9 - 88
- Power Consumption 16W / 0.14A
- Base of arm rotation 180 - 300°
- Input Voltage 100 - 240V AC 50/60 Hz
- Output Voltage 12V DC / 1A
- Head rotation 320°



**HCL585** X700 Wall Mounted Light

**HCL586** X700 Rail Clamp Light

**HCL587** X700 Desk Clamp Light

**HCL588** X700 Fixed Desk Mount Light

**HCL589** X700 Mobile Mounted Light

**HCL591** X710 Wall Mounted Light with IEC Cable

**HCL592** X710 Wall Mounted Light with Flush Fitting Kit

**HCL593** X710 Rail Clamp Light with IEC Cable/Curled IEC

**HCL594** X730 Panel Mount Light with Flush Fitting Kit

**HCL595** X740 Ceiling Mounted Light

**HCL596** X740 Wall Mounted Light

**HCL597** X740 Rail Clamp Light

**HCL598** X740 Desk Clamp Light

**HCL599** X740 Desk Stand Light

**HCL600** X740 Fixed Desk Mounted Light

**HCL601** X740 Mobile Mounted Light



## DARAY® S4 Series Minor Surgery LED Light

The Daray S430 series is an invaluable and cost effective tool. It has been specifically designed for minor procedures under local anaesthetic in health centres, GP surgeries and outpatient departments.

The use of Multiple LED's provides a high, and even light intensity throughout the entire viewing area to reduce eye strain. A concise and self-explanatory three button control system is situated on the lighthead itself. Balanced arms for one touch adjustment and a great range of movement.

Designed to provide consistent, accurate light where it's needed, along with great shadow reduction and great colour rendering.

- Digital control panel on side of light head
- Light Intensity @ 0.75m: 90,000 lux ± 5%
- Light Intensity @ 1m: 70,000 lux ± 5%
- Colour Temperature: 4,000K
- Colour Rendering Index (CRI): > 95
- Colour Rendering (R9): 90
- Light Field Diameter (d50) 200mm
- Light Intensity Adjustment Range 9 Stages (10% - 100%)
- Temperature Rise on Surgeon <2°C
- Average working life >50,000 Hours

**HCL460** Mobile Minor Surgery Light

**HCL461** Ceiling mounted Minor Surgery Light

**HCL462** Wall mounted Minor Surgery Light

## DARAY® MAG700 Magnifying Examination Light

The Daray MAG700LED light is a high-quality circular magnifying light featuring an LED light source that enhances colour contrasts whilst reducing shadow.

This general-purpose magnifier has steady movement to a reach of 800mm and is desk mounted as standard. With smooth contours and dust cover protect the lens, the MAG700LED magnifying light is perfect for a variety of applications.

**Other mounting options are also available.**

- LED technology (80 LEDs)
- Low total cost of ownership
- Robust with long lamp life
- Slim design
- 3, 6 and 12 dioptre options
- 800mm reach
- Fully enclosed spring-balanced arm

**HCL356** LED 3-Dioptre Desk Clamp Light

**HCL357** LED 6-Dioptre Desk Clamp Light

**HCL358** LED 12-Dioptre Desk Clamp Light

**HCL540** LED 3-Dioptre Mobile Light

**HCL542** LED 6-Dioptre Mobile Light

**HCL544** LED 12-Dioptre Mobile Light

**HCL539** LED 3-Dioptre Wall Mount Light

**HCL541** LED 6-Dioptre Wall Mount Light

**HCL543** LED 12-Dioptre Wall Mount Light



## DARAY® S4 Series Operating Theatre Light



The DARAY S4 Series Operating Theatre Light has been designed to provide a high intense beam with excellent shadow dilution and accurate colour rendering. The S4 series is available as a wall, ceiling or mobile - dual or single arm. All versions have a smooth, fully enclosed head to aid in the management of infection control. A spring balanced arm makes positioning extremely easy, providing a precise and stable beam.

Features include: variable intensity, focusable beam and a digital control panel. The SL400 series is an extremely cost effective lighting solution that meets the needs of a demanding operating theatre.

- LED light source with digital control panel
- Cool and comfortable beam
- Lightweight and slim light head for excellent laminar flow
- Multi-lens geometry lighting system
- Low energy consumption
- Focusable beam
- Excellent shadow reduction
- 40,000 hours from the LED module
- Low 'total cost of ownership'
- 4,300°K colour temperature
- Integrated camera options available
- Available in ceiling, wall and mobile

- **Diameter of light head 450:** 500mm
- **Diameter of light head 470:** 700mm
- **Luminance (Lux) @ 1m 450:** 120,000 lux
- **Luminance (Lux) @ 1m 470:** 160,000 lux
- **Colour Field Temperature (K):** 4,300 ±500°K
- **Light Field Diameter:** 120 to 350mm
- **Colour Render Index (Ra):** >95
- **Colour Render Index (R9):** >97
- **Temperature Raise on Surgeon:** < 2°C
- **Number of LEDs 450:** 54
- **Number of LEDs 470:** 108
- **Standard Installation Height 2.7m:** 3.3m

Spec. dependant on configuration selected – Contact for advice



<b>HCL649</b>	S450 Ceiling Mounted Single Head Light
<b>HCL650</b>	S470 Ceiling Mounted Single Head Light
<b>HCL651</b>	S450 Wall Mounted Single Head Light

<b>HCL652</b>	S450/450 Ceiling Mounted Dual Head Lights
<b>HCL653</b>	S450/470 Ceiling Mounted Dual Head Lights
<b>HCL654</b>	S470/470 Ceiling Mounted Dual Head Lights

## DARAY® S7 Series Operating Theatre Light



Utilising the most advanced LED technology available, the NviroLED S7 series of operating theatre lights have been designed to provide a high quality, shadowless beam with extremely low running costs.

The new, slim, fully enclosed head with colour touch-screen digital controls is a perfect LED lighting solution complementing all surgical rooms.

- Streamlined, ultra-thin enclosed head with reduced air resistance to minimise contamination
- Low 'total cost of ownership'
- 4,000 to 5,000°K variable colour temperature
- Flat, pressure injection moulded light panel making it a robust lighting solution
- Digitally controlled light intensity with 10 varying grades of brightness and automatic memory for added user flexibility
- Built in power supply systems avoiding complicated installation of wall mounted control box
- Auxiliary light source included for laparoscopic operations
- LED light-source with up to 40,000 hours of light
- Rigid suspension arm with easy mobility and stable positioning
- 360° arm rotation
- No infrared or ultraviolet radiation

- **Light Intensity 750:** 120,000 lux
- **Light Intensity 770:** 160,000 lux
- **Colour Temperature:** 3,600 to 5,500°K
- **Colour Render Index (CRI):** >95
- **Colour Render Index (R9):** 95
- **Light Patch:** 120–240mm
- **Focusing Depth 750:** 1000mm
- **Focusing Depth 770:** 1000mm
- **LED Power 750:** 45W
- **LED Power 770:** 60W
- **Power Supply:** 220V 50Hz
- **Number of LEDs 750:** 45
- **Number of LEDs 770:** 60
- **LED Life:** 50,000 hours



<b>HCL655</b>	S780 Ceiling Mounted Light
<b>HCL656</b>	S780 Wall Mounted Light
<b>HCL657</b>	S780 Mobile Operating Theatre Light
<b>HCL658</b>	S780/780 Ceiling Mounted Dual Head Lights





3 Year  
Warranty



## DARAY® S740 Minor Surgery LED Light

The S740 is the latest addition to the DARAY® LED surgical lighting range. Suited for all minor procedures, and available in a range of mounting choices.

This minor surgical light boasts excellent shadow reduction via a wide array of LED's - designed to provide consistent and accurate light where it is needed. A digital control panel, located on the light head itself, offers convenient adjustment of light intensity, colour temperature and Endoscopy Mode control. A smooth, fully-enclosed light head and arm system assists with the management of infection control.

- Light source: LED
- Light intensity (lux) @ 1.0m: 70,000 lux ±5%
- Intensity adjustment range: 50% - 100% (4 stage)
- Colour temperature (Kelvin): 3,600 - 6,000K ±500
- Colour adjustment range: Variable (3 stage)
- Light field diameter (D50) @ 1.0m: 214mm
- Light field diameter (D10) @ 1.0m: 108mm
- Colour rendering index (CRI): 100 ≥ Ra ≥ 85
- Depth of illumination: 950mm
- Average working life: >40,000 hours

**HCL646** S740 Ceiling Mounted Light

**HCL647** S740 Wall Mounted Light

**HCL648** S740 Mobile Light

## HEINE® EL3 LED Examination Light

- The EL 3 LED provides (typ. 42,000 lux / typ. 350 lumen), shadow-free illumination precisely at the point of interest, at a working distance of 30 cm.
- The new standard in LED illumination defining optimal light intensity, homogeneity and colour rendering for the most accurate diagnosis. Red is red, blue is blue. A white light with a colour temperature of typ. 5,000 K, Colour Rendering Index (CRI) > 90
- Shadow-free illumination. The compact illumination head (Ø approx. 60 mm) allows convenient, precise positioning, particularly in difficult application situations. Optimal position eliminates unwanted shadows in the illuminated field.
- Cool-Touch closed head design makes disinfection easy.
- Optimal positioning. The light weight head and stable goose neck allow easy and intuitive adjustment and keep the light exactly in the required position.
- Various mounting options, including table clamps and wall mounts are available for this examination light



**HCL485** EL3 LED Examination Light with Wall Mount

**HCL486** EL3 LED Examination Light with Table Clamp

**HCL487** EL3 LED Examination Light with Wheel Stand

**HCL486.1** Table Clamp Mounting for EL3 LED

**HCL487.1** Metal Base Wheel Stand with Mount for EL3 LED

**HCL487.2** Mount for Wheel Stand EL3 LED

## HEINE® EL3 LED Examination Light

The EL 10 LED examination light distinguishes itself through an absolutely homogeneous field of light.

- Perfect illumination, light intensity can be regulated continuously between 6,500 and 45,000 Lux.
- The spot size can be adjusted in a diameter between 8.5 and 14 cm LED in HQ - 10 Watt high performance LEDs
- The compact illumination head (Ø approx. 60 mm) allows an almost coaxial illumination
- Solid construction with reliable operation with 3 mount options
- Easy and efficient cleaning and disinfection
- Ergonomic coiled goose neck grip allows for intuitive and fast adjustment of brightness and spot size.
- An electrical control system monitors all functions and guarantees safety



**HCL443** EL10 LED Examination Light with Wall mount

**HCL444** EL10 LED Examination Light with Table Clamp

**HCL445** EL10 LED Examination Light with Wheeled Stand

**HCL446** Clamp for Table mounting for EL10 LED

**HCL447** Wheeled stand with Metal Base & Mount for EL10 LED

**HCL448** Mount for wheeled stand

## Brandon Medical Coolview CLED23

The 360° rotation of light around the ceiling pole and 360° of the light head allows the user to position the light beam to suit any procedure without any restrictive stops or twisted cables. With a 210mm diameter light spot with exceptionally high brightness of 60,000 Lux @ 0.5m. Adjustable colour for internal and external examinations.

### Long Lifecycle

CLED23 provides uncompromising lighting performance for the clinician. Its high intensity performance and colour corrected light make the focus of the examination vivid and natural. The CLED23 is a perfect light for dermatology, ENT, Gynaecology and sensitive areas such as neonatal and ICU departments.

### Highest Light Quality

CLED23 emits 60,000 lux of intense bright light at 0.5m, providing a pool of clear light during procedures. The light intensity can be altered through 4 easily selectable settings providing a suitable level of intensity for all procedures.

### Large Illuminated Area

A large illuminated area of 210mm diameter makes it easy to examine large areas of tissue and makes it easier to target the light on the patient.

### High Colour Rendition

CLED23 reproduces all of the visible colours naturally and accurately. The high Ra of > 95 describes the exceptionally high quality of white light whilst the high R9 of > 90 measurement describes how it accurately reproduces visible red.

### Colour Control Settings

CLED23 allows the user to adjust the colour temperature of the light source. This enhances the clinician's ability to recognise and distinguish tissue conditions. The warm white (3,500°K) setting is ideal for dermatological examinations and the daylight white setting (4,500°K) is ideal for the recognition of blood vessels.

- **Illuminance field** 60,000 @ 0.5m
- **LED Life** 30,000 hours
- **Colour Temperature** 3,500°K & 4.500°K
- **Class of Protection** II
- **Safety Standard** EN 60601-1, EN60601-2-41

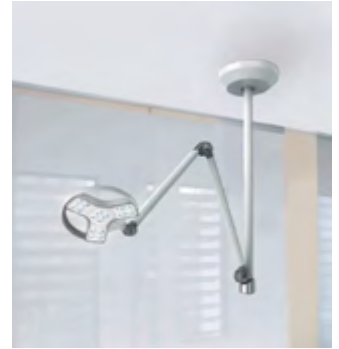

**HCL424** Coolview CLED23 Back-plate mounted Examination Light

**HCL425** Coolview CLED23 Desk mounted Examination Light

**HCL426** Coolview CLED23 Wall mounted Examination Light

**HCL427** Coolview CLED23 Rail mounted Examination Light

**HCL428** Coolview CLED23 Mobile Base Examination Light

**HCL429** Coolview CLED23 Ceiling mounted Examination Light

**HCL158** Coolview 1m Rail Mount Accessory Kit

## Brandon Medical Coolview CLED53

The perfect light source for a wide range of procedures. Providing a high intensity, bright natural looking light, Coolview CLED53 is perfect for medical consultations and examinations in primary care and medical clinics.

Powerful, variable light intensity Coolview CLED53 emits a powerful 50,000 Lux of light at 0.5 metre, providing an intense, clear light source for excellent visualization. The easily accessible and intuitive controls offer 5 levels of brightness.

### Infection Control

The fully enclosed light head is sealed to protect from dust and light liquid ingress.

### Mountings

The CLED53 Examination Light operates on a spring balanced rigid arm offering optimum reach, positioning and stability. The light can be specified for mounting on the wall (with or without backplate), desk, "medirail" or on a mobile wheeled base.

### Perfect Colour

The powerful light source is matched with a selectable colour temperature feature, which can be adjusted between 3,300, 3,800°k and 4,400°k This provides the clinician with accurate representation and visualization of the site under examination. Coolview CLED53 offers a high CRI Ra of ≥93 which describes the exceptionally high quality of white light and excellent overall colour rendition, whilst the high CRI R9 value of ≥90 can help to enhance visualization of areas where red is more predominant.



**HCL641** Coolview CLED53 FX Back Plate (Wall) Mounted

**HCL642** Coolview CLED53 FX Desk (Clamp) Mounted

**HCL643** Coolview CLED53 FX Mobile

**HCL644** Coolview CLED53 FX MediRail Mounted

**HCL645** Coolview CLED53 FX Wall Mounted

**HCL158** Coolview 1m Rail Mount Accessory Kit

## Brandon Medical Coolview CLED50

**A powerful examination light with light intensity of 50,000 Lux**

The perfect light source for a wide range of procedures. Providing a high intensity, bright natural light, Coolview CLED50 is perfect for medical consultation in primary care and medical clinics.

It emits 50,000 Lux of bright natural light at 0.5m providing an intense, clear light source for use in general consultation areas.

The colour corrected light source with a colour temperature of 4,400°K allows for accurate representation of tissue during examination.

### Choice of FX Spring Balanced or SX Multi-flex Arm

FX spring-balanced arm ensures smooth, easy positioning and the arm will stay fixed into position without drifting. The arm has a reach of 940mm and includes an integrated transformer.

SX multi-flex arm ensures smooth and easy positioning but with an enhanced flexible arm for precise positioning. The arm has a reach of 850mm and includes an integrated transformer. The SX arm also has a turn restrictor to prevent it from accidental removal from the fixing brackets.

**HCL631** Coolview CLED 50 FX Back Plate Mounted

**HCL632** Coolview CLED 50 FX Desk Mounted

**HCL633** Coolview CLED 50 FX Mobile

**HCL634** Coolview CLED 50 FX Rail Mounted

**HCL635** Coolview CLED 50 FX Wall Mounted

**HCL636** Coolview CLED 50 SX Back Plate Mounted

**HCL637** Coolview CLED 50 SX Desk Mounted

**HCL638** Coolview CLED 50 SX Mobile

**HCL639** Coolview CLED 50 SX Rail Mounted

**HCL640** Coolview CLED 50 SX Wall Mounted

- Fully enclosed spring balanced arm
- Base arm rotation 360°
- Sealed head to protect from dust and light liquid ingress
- **Modern concept, designed ergonomically to suit daily use by clinical staff**
- Coolview CLED50FX has a high Ra of 93 which describes the **exceptionally high quality of white light** whilst the high measurement of R9 of 90 describes how accurately it illuminates tissues
- **Base joint Angle adjustment:** 170°
- **Light intensity:** 50,000 Lux @0.5m
- **Colour temperature:** 4,400 °K
- **Illuminated area:** 180 mm @0.5m
- **Colour Rendering Index (Ra):** 93
- **Colour rendering (R9):** 90
- **Head Rotation:** 300°



**SX Multi-flex Arm**



**FX Spring Balanced Arm**



## Brandon Medical Coolview CLED30

**A powerful examination light with light intensity of 30,000 Lux**

An ideal light for general examination within GP consulting and examination rooms with a bright white LED light, it renders skin tones realistically, which is critical for correct diagnosis.

Coolview CLED30SH is designed for gynaecological use, such as pap smears and gynaecological examinations.

The modern design of CLED30SV examination light will inspire confidence in your patients whilst the ergonomics of the head combined with the flexible arm will allow you to handle and position the light effortlessly.

**HCL619** Coolview CLED 30 SH Horizontal Back Plate Mounted

**HCL620** Coolview CLED 30 SH Horizontal Desk Mounted

**HCL621** Coolview CLED 30 SH G-Clamp Mounted

**HCL622** Coolview CLED 30 SH Mobile

**HCL623** Coolview CLED 30 SH Rail Mounted

**HCL624** Coolview CLED 30 SH Wall Mounted

**HCL625** Coolview CLED 30 SV Back Plate Mounted

**HCL626** Coolview CLED 30 SV Desk Mounted

**HCL627** Coolview CLED 30 SV G-Clamp Mounted

**HCL628** Coolview CLED 30 SV Mobile

**HCL629** Coolview CLED 30 SV Rail Mounted

**HCL630** Coolview CLED 30 SV Wall Mounted

An affordable, professional looking and powerful examination light for your practice.

- Continuous dimming
- Robust, easy to handle
- Wide illuminated area 180mm @ 0.5m
- Modern concept, designed ergonomically to suit daily use
- Sealed head to protect from dust and light liquid ingress
- Excellent colour rendering to show natural skin tones
- **Light intensity:** 30,000 Lux @0.5m
- **Colour temperature:** 4,400 °K
- **Illuminated area:** 180 mm @0.5m
- **Colour Rendering Index (Ra):** 93
- **Colour rendering (R9):** 90
- **Head Rotation:** 300°



**SH Parell Head**



**SV Perpendicular Head**

## Brandon Medical Coolview CLED10

The perfect light source for a wide range of procedures - its high intensity from the unique diamond optics means it is ideal for medical consultation in primary care and medical clinics!

### Delivering high illumination

CLED10 emits 50,000 Lux of bright natural light at 0.5m providing an intense, clear light source for use in general consultation areas. The light intensity is fixed at an optimised level for general examination and ease of use.

### Colour corrected light source

The colour corrected light source with a colour temperature of 4,400°k allows for accurate representation of tissues.

### High colour rendition

CLED10 reproduces all of the visible colours naturally and accurately. The high Ra of  $\geq 93$  describes the exceptionally high quality of white light.

### Comfortable, cool light source

CLED10ST does not emit any infrared radiation, avoiding heat exposure during examinations.

### Large illuminated area

A large illuminated area of 180mm diameter makes it easy to examine large areas of tissue and makes it easier to target the light on the patient.

### Intuitive and Ergonomic

The elegant arm ensures smooth and easy positioning with enhanced flexibility for precise positioning. The lamp head can be rotated 280° using the ergonomic handle and switched on using the I/O intuitive switch.

- Colour corrected to natural daylight for accurate representation of tissues
- Manoeuvrable, 870mm reach multiflex arm
- Lamp head rotates at 280° for easy positioning
- Environmentally friendly, low power consumption
- Emits a cold light with no infrared radiation

- **Light intensity (at 0.5m):** 50,000 Lux
- **Beam Size:** 180mm (at 0.5m)
- **Colour Temperature:** 4,400°K
- **Colour Rendition Index Red (R9):** >91
- **Colour Rendition Index (Ra):** >93
- **Head Rotation:** 280°
- **Safety Standards:** EN60601-1, EN60601-2-41 & EN60601-1-2



**HCL549** Coolview CLED10ST Back Plate Mounted Examination Light & Wall Bracket

**HCL550** Coolview CLED10ST Desk Mounted

**HCL551** Coolview CLED10ST Mobile Mounted

**HCL552** Coolview CLED10ST Rail Mounted

**HCL553** Coolview CLED10ST Wall Mounted

## Brandon Medical Optica MDV & WOODS LED Magnifiers

The Optica MDV and the Optica Woods, partner two lighting modes; LED and optional Woods light, to create an innovative magnifier.

This product is an approved medical device, meaning it can be used within a range of different practices including dermatology, dentistry, veterinary, and in laboratories for monitoring sterilised products.

The wood light can diagnose skin conditions that may be missed under a standard LED light. Most wood luminaires require the room to be darkened to use, yet the Optica Woods can function without thanks to the powerful BLB LEDs

- Superior scratch-resistant 6500 K LED lights ensure less shadow formation and optimal colour rendering
- Large magnifier diameter of 153mm with an impressive 1.9x(3.5 dioptr) magnification
- Optica MDV and Woods boasts an excellent daylight-quality light filed
- Spring balanced arm and friction joints allow smooth handling without the luminaire head sinking
- The luminaire arm allows a reach of up to a 108cm radius

- **Lens Diameter 157mm**
- **No. Of Dioptr:** 3.5
- **Colour Temperature:** Daylight White 6500°K
- **Colour Rendition Index (Ra):** >93
- **Colour Rendition Index (R9):** >90
- **Colour Rendition Index (R13):** >95
- **Colour Temperature Daylight White:** 6000 lux (at 0.15m)



**HCL575** Optica MDV Desk Mounted Medical Magnifier

**HCL576** Optica MDV Mobile Base Medical Magnifier

**HCL577** Optica MDV Rail Mounted Medical Magnifier

**HCL578** Optica MDV Wall Mounted Medical Magnifier

**HCL579** Optica MDV Ceiling Mounted Medical Magnifier

**HCL580** Optica Woods Desk Mounted Medical Magnifier

**HCL581** Optica Woods Mobile Base Medical Magnifier

**HCL582** Optica Woods Rail Mounted Medical Magnifier

**HCL583** Optica Woods Wall Mounted Medical Magnifier

**HCL584** Optica Woods Ceiling Mounted Medical Magnifier

## Brandon Medical Astralite Telescopic Mobile

Provides a mobile minor surgery and examination light which optimises the use of space, whilst allowing you the option of moving it anywhere in the practice.

Astralite® Telescopic offers the benefits of the Astralite range, on a mobile base with an adjustable height stand, with a vertical range between 1,100–1,800 mm, with two options available for light intensity: 70,000 Lux and 100,000 Lux.

HD-LED® is a breakthrough technology with vastly better performance than Standard LED or conventional surgical lights.

Designed so that the light head can be positioned all the way around the couch to examine all parts of the patient.

Uses less than 32 VA. LEDs are mercury-free and do not contain CFCs, POPs, VOCs, halogens or other harmful chemicals. Never having to change a bulb for the lifetime of the product means that Astralite® is highly economical. LED is substantially more efficient at producing more surgical quality light for less power.

- Adjustable height stands 1,100–1,800 mm
- 70,000 Lux (AL10 Models) and 100,000 Lux (ALE10 Models)
- Unlimited 360-degree lamp head rotation
- 1m working distance from light head
- >50,000 hours LED life
- 70-degree fixed arm angle
- 13 light sources

**HCL606** ALE10 (100 K-Lux) Telescopic Mobile A/C Input

**HCL607** ALE10 (100 K-Lux) Telescopic Mobile D/C Input

**HCL608** AL10 Telescopic (70 K-Lux) Mobile A/C Input

**HCL609** AL10 Telescopic (70 K-Lux) Mobile D/C Input

- **Light intensity @ 1 metre:**  
AL10 70,000 Lux (Adjustable 8 steps)  
ALE10 100,000 Lux (Adjustable 8 steps)
- **Colour temperature:** 3,500°K - 5,000°K
- **Variable light intensity:** 5% -100%
- **Beam size at 1m:** 180mm
- **White light (Ra):** >95
- **Red colour (R9):** >95



## Brandon Medical Astralite eLite 10

Designed for every need - from minor procedures, suturing, A&E, dermatology to gynaecology. Offers high colour rendition due to its unique, highly recognisable warm and cold light LED - a Brandon Medical patent - and large illumination field.

The Astralite minor surgical light uses HD-LED technology to deliver high quality lighting for any procedure producing up to 100,000 lux of intense bright light with intuitive controls and a unique "Auto On" feature.

The "Auto On" feature turns the light on as soon as the user touches any control. Its clear and simple wipe clean controls provide adjustments of intensity and colour, whilst the field size can be adjusted to suit the surgical site using the ergo handle.

**Note:** Ceiling mounted models are intended to be wired in to the mains while mobile models are supplied with a lead and plug

- Large movement range of 5 rotations which allow easy positioning of the light around the examination table.
- Has shadow control by spreading LEDs across the whole lighting surface, which provides better distribution of light.
- Clear and simple wipe clean controls provide adjustments of intensity and colour, whilst the field size can be adjusted to suit the surgical site using the ergonomic handle.
- Astralite® reproduces all of the visible colours naturally and accurately. The high Ra>95 describes the exceptionally high quality of white light whilst the high R9>95 measurement describes how it accurately illuminates red tissue.
- Illuminated area of 180mm diameter ensures you can illuminate large areas of tissue and target light on to the wound.
- The beams of light from Astralite® have a focus depth of 600mm to penetrate into deep cavities.

- **Colour Temperature:** 3500–5000°K
- **Variable light intensity:** 5% -100%
- **Beam Size at 1m:** 180mm
- **Colour Rendition Index (Ra):** >95
- **Colour Rendition (R9):** >95
- **Depth of Illumination:** 600mm
- **LED Life:** >50,000 hours



**HCL557** ALE10 Ceiling Mounted Light (100 K-Lux)

**HCL558** ALE10 Mobile Light (100 K-Lux)

**HCL559** ALE10 Mobile Light With Battery (100 K-Lux)

**HCL611** ALE10 Wall Mount Light (100 K-Lux)

**HCL612** ALE10 Tandem Mounted Light (100 K-Lux)

**HCL613** ALE10 Lamp Head (Only)

## Brandon Medical Astramax HD-LED

A powerful compact surgical luminaire with an impressive light output of 150,000 lux, comparable with larger surgical luminaires.

It features an ultra slim and light-weight lamp head which enables smooth, fast and precise positioning during procedures.

The lamp head is mounted on multi-movement arm mechanisms that are capable of positioning the lamp head within an exceptionally wide envelope of movement. The lamp has 5 rotations to allow easy positioning of the light beam from any angle.

Astramax HD-LED provides exceptional performance at a competitive price with minimal running costs. Using less than 50 Watts of power and with 60,000 hours of LED life, Astramax continually saves money on energy and maintenance. Astramax LED life of 60,000 hours equates to more than 20 years of normal use.

- Ultra slim and light-weight lamp head enables smooth, fast and precise positioning during procedures.
- LED life of 60,000 hours equates to more than 20 years of normal use.
- Better distribution of light is provided from the lamp head by the spreading of LEDs across the whole lighting surface. This enables excellent shadow control to under-light obstructions during procedures.
- The lamp has 5 rotations to allow easy positioning of the light beam from any angle.
- Using less than 50W of power and extensive LED life, Astramax continually saves money on energy and maintenance.
- IP54 to protect from ingress of dirt and fluids

- **Lux at 1.0m:** 150,000 Lux
- **Variability Intensity:** 5% - 100%
- **Colour Rendition Index Ra:** 95
- **Red Colour (R9):** 98
- **Colour Temperature:** 3100°K - 5000°K
- **Beam Size at 1.0m:** 90 - 320mm variable
- **Reach:** 850mm - 1020mm (mobile base), 1650mm - 1800mm (ceiling and wall mounts)



<b>HCL563</b>	AM30 Ceiling Mounted Duo
<b>HCL564</b>	AM30 Ceiling Mounted Tandem
<b>HCL565</b>	AM30 Ceiling Mounted Light
<b>HCL566</b>	AM30 Mobile Light with Battery Back Up
<b>HCL567</b>	AM30 Mobile Unit
<b>HCL568</b>	AM30 Wall Mounted Light
<b>HCL568.1</b>	AM30 Wall Mounted Light (Requires remote PSU ZE050H-SW)
<b>HCL568.2</b>	AM30 / ALE10 Ceiling Mount Tandem
<b>HCL564.1</b>	AM30 Tandem With Accessory Arm



<b>HCL569</b>	Glamox Luxo Circus Medical 3.5d c/w clamp bkt White
<b>HCL570</b>	Trolley Stand Medical
<b>HCL571</b>	Extra weight Trolley
<b>HCL572</b>	4d Suction lens
<b>HCL573</b>	6d Suction lens
<b>HCL574</b>	10d Suction lens

## Glamox Luxo Circus LED Illuminated Magnifier (Dimmable)

Circus LED is well suited for demanding work in, Hospitals, GP Surgeries, or Beauty Salons. Circus LED has a large lens, aluminium head and a highly flexible self-balancing arm and shade neck.

This excellent magnifier's light source is a circular LED module with good colour rendering. The shade neck can be positioned horizontally, vertically or laterally, allowing it to be very flexible.

The lens permits comfortable viewing for both eyes. Standard version with 3.5 lens and table edge clamp. A secondary suction lens of 4, 6 or 10 diopters can be attached.

- Body material & colour: Steel arm with aluminium head. Shade neck cover in rubber
- Colours: white arm and white head, plastic parts on the shade in black. White plastic covers on the arm.
- Mounting: Standard with table clamp (AH clamp). Other options -Trolley Floor Stand with extra weight
- Optics : Standard with 3,5D lens. Lens diameter is 165 mm.5D lens available on request
- Secondary lens: Additional lenses 4D, 6D or 10D can be added
- Arm features: Parallel, three-pivot arm with length of 100cm
- Light source : LED: 750lm out (4000K)
- Dimmable: 10-100%.
- Medical approvals certificates: IEC/EN 60601-1, IEC/EN 60601-1-2
- Colour rendering index (CRI): 90



## Glamox Luxo LHH LED G2 Examination Light

### LHH LED G2 Dimmable

Ideal for general patient examination, minor treatments, gynaecology, maternity & neonatal, obstetrics, cosmetic surgery (e.g. Botox). All environments where a level of illumination up to 35,000 lux is required.

- Parallel, three-pivot arm with length of 105cm
- Light Source - Supplied LED cluster lamp
- Lifetime - Minimum 50,000 hours
- Lux Level at 1.0m - 35,000 lux
- Lux Level at 0.5m - 120,000 lux
- Dimming - On/Off and seamless dimming
- Colour Temperature - 4000K
- Colour Rendering Index (CRI) - Ra95, R9: 98 at 4000K
- Antimicrobial Powder Coating - SteriTouch® Prevents the growth of bacteria, biofilm and mould
- Medical approvals and certificates - IEC/EN 60601-1, IEC/EN 60601-1-2. Class 1, Medical CE mark
- Mountings to be purchased separately

### LHH LED Tunable CCT Dimmable G2

Ideal for general patient examination, minor treatments, maternity, dermatology, blood vessel recognition, cosmetic surgery (e.g. Botox) or mortuary (e.g. Post mortem table) uses. Adjustable colour temperature with warm white setting, ideal for the recognition of blood cells.

- All features/specs are as above, with the exception of:  
Lux Level at 1.0m - 25,000 lux  
Lux Level at 0.5m - 105,000 lux



**HCL501** BSP Wall Bracket/Plate - White (for HCL500/HCL508)

**HCL503** Trolley Floor Stand - White (for HCL502/HCL509)

**HCL506** Ceiling Mount - White (for HCL505/HCL511)

**HCL507** Ceiling Void Mount - White (for HCL505/HCL511)

**HCL500** LED G2 Wall - White

**HCL502** LED G2 Trolley Floor Stand - White

**HCL505** LED G2 Ceiling Mounted - White

**HCL508** LED CCT G2 Wall - White

**HCL509** LED CCT G2 Trolley Floor Stand - White

**HCL511** LED CCT G2 Ceiling Mounted - White

## Glamox Luxo Aim-HI 700 LED

An examination and Minor Surgery light that optimises design, performance, and value. AIM HI LED precisely positioned, high-intensity LED modules reduce shadows and produce a larger and adjustable light pattern. User-friendly dimming and focus controls are conveniently located on and near the light head handle. Drift-free arm and mounting systems offer the user flexibility, reach, and ease of placement. Ideal for Ambulatory, Dermatology & Plastic Surgery.

- 70,000 lux (6503 fc) at 1 meter (AIM HI 70) - 37 watts
- 4300 K colour temperature
- CRI (Colour Rendering Index) of >95
- 3-step dimmable (100% / 75% / 50%) using easy-to-reach push-button controls
- Multiple LED system helps minimize shadowing
- Larger adjustable light pattern
- Focus by rotating centre handle
- 360° limitless arm rotation (single ceiling mount)
- Smooth design; easy to clean
- Certifications/Approvals: IEC 60601-1 / IEC 60601-1-2 / IEC 60601-2-41 / IEC 60601-1-6



**HCL662** Single Ceiling ALED070SC White

**HCL662.1** Floor Stand ALED070FLO3 White

**HCL662.2** Wall ALED070W White

## Glamox Luxo Carelite LED Patient Bedhead light



Ideal for Patient reading light and minor bedside procedures.

### Integrated night-watch

Carelite is equipped with night-watch, an observation light for the nurse to check on the patient.

### Exact positioning

Carelite has a covered spring balanced arm for easy cleaning and safe and easy positioning. The flexibility and precision of the spring balanced arm means that Carelite can be positioned exactly where the light is required.

### All-metal construction

Carelite is made of powder-coated metal, ie aluminium & steel.

### Protected by SteriTouch®

Carelite is painted with SteriTouch® antimicrobial powder coating, which prevents the growth of bacteria, biofilm and mould. Based on ionic silver technology, the antimicrobial performance remains effective indefinitely.

### Easy replacement

The new Carelite features the same arm construction and spigot as the traditional version. This means that all brackets and clamps can be reused with this new version.

### LED – light source of the future

Light emitting diodes are not only small and robust. Carelite's LEDs are extremely energy efficient, and have an incredible life span of up to 50,000 hours or more. The powerful LED module has a light output giving approximately 2,000 lux at 0.6 metres.

**HCL512** G2 Dimmable, Night-watch & SteriTouch® w105mm

**HCL513** G2 Dimmable, Night-watch & SteriTouch® w115mm

**HCL501** BSP Wall Bracket/Plate – White (for HCL500/HCL508)



## Riester ri-magic HPLED

### Latest improved HPLED technology

High performance LED light for diagnosis and procedures. Illuminates the examination and operation area in the best possible way. The white focusable LED illumination offers more a bright light for a more efficient diagnosis.

- Highly flexible, long arm can be bent in all directions
- Rheostat handles for continuous adjustment of light intensity
- Wide-range power supply for 230V/120V
- Available with a choice of plugs to suit the electrical outlets in your country upon request
- Available as mobile, wall and examination table or desk design
- Sturdy mobile base made of fibreglass and chrome plated pole, diameter 54 cm (21.3 in), easy to move due to low friction castors (antistatic, two castors can be locked)
- **Lifetime of the bulb:** up to 50,000 hours
- **Distance of 400mm:** max. 130,000 Lux and Ø 230 mm
- **Distance of 600mm:** max. 70,000 Lux and Ø 320 mm
- Colour temperature: 5,700 K
- CRI: 93

**HCL300** Riester ri-magic desk with LED

**HCL301** Riester ri-magic wall with LED

**HCL302** Riester ri-magic floor with LED





## Transit Chrome Wheelchair

- Detachable armrests and swing away footrests
- Folds for easy storage and transport
- Moulded arm rests for extra comfort
- Adjustable leg rests with wipe clean seat fabric
- Chrome plated steel frame with Stainless steel skirt guards
- Narrow variants available - ideal for indoor use
- Folding back available - makes the chair even more compact
- Optional elevating leg rests, desk arms & adjustable I.V pole

**HDA001** Transit Chrome Wheelchair 46cm



## Whirl Wheelchair

- **Available as:** attendant-propelled or self-propelled
- Designed to be a simple yet versatile wheelchair ideal for both part time or full time use
- The Whirl's narrow frame and compact dimensions ensure great manoeuvrability indoors and in confined spaces
- Fully padded upholstery with calf support strap for comfort
- Detachable folding backrest for compact storage
- Removable desk armrests enable you to get closer to tables
- Removable quick release rear wheels on the self propelled version to make the chair lighter to lift
- Puncture proof-tyres provide extra peace of mind outdoors
- One Year Parts Warranty plus Two Year Main Frame Warranty
- **Maximum User Weight:** 115kg / 18st
- **Seat width:** 41-48 cm



**HDA422** Whirl Wheelchair Self Propelled 41cm

**HDA423** Whirl Wheelchair Attendant Propelled 41cm (Shown)

## Swift Wheelchair

- **Available as:** self or attendant-propelled with cable brakes
- Designed for indoor or outdoor occasional use
- Lightweight aluminium frame which easily folds and dismantles without any tools
- Compact design makes it very easy to use indoors
- Robust puncture-proof tyres for simple maintenance
- Quick release wheels are fitted on the self propelled model.
- By removing the wheels the overall weight is reduced, the chair is easier to lift and the chair is more compact to store
- Half-folding back to make reaching for objects behind you easier - This also makes the chair more compact for storage
- One Year Parts Warranty plus Two Year Main Frame Warranty
- **Maximum User Weight:** 115kg / 18st
- **Seat width:** 41 or 46cm



**HDA420** Swift Wheelchair Self Propelled 41cm (Shown)

**HDA421** Swift Wheelchair Attendant Propelled 41cm

## Integra Pressure Relief Tilt Chair

Developed as an aid for moving and handling residents around in nursing home environments. It is an ideal transfer aid and provides the user with great comfort and support.

- Tilt in space chair - gas strut operated.
- The chair will rise and tilt users to their feet.
- Easy inclination with ergonomically designed push handle
- Velcro attached ergonomically designed headrest
- Lap belt is fitted as standard for additional safety.
- Handy storage pocket on the backrest.
- Easy to manoeuvre high quality brake wheels
- Two-way stretch, breathable Dartex material in seat

**HDA649** Integra Shell Chair - 39cm (16')

**HDA650** Integra Shell Chair - 45cm (18')

**HDA651** Integra Shell Chair - 51cm (20')



## Indiana Single Motor Rise & Recliner

Upholstered in a soft feel Chenille fabric which provides added luxury and comfort. The riser has a modern design which will suit any décor, and is available in four attractive colours.

- Single, quiet motor activates distinct lift, rest & recline action
- It will rise and tilt users to their feet with ease
- Comes with a simple to operate two button handset
- Convenient side pocket for easy storage
- Excellent snooze position for supreme comfort and relaxation
- Fully padded chaise for increased comfort
- Quality assured, meets all relevant fire retardancy standards



**HDA637** Indiana Armchair - Biscuit

**HDA638** Indiana Armchair - Mushroom

**HDA639** Indiana Armchair - Charcoal

**HDA640** Indiana Armchair - Berry

## Memphis Dual Motor Rise & Recliner

Upholstered in a soft feel Chenille fabric with a memory foam seat providing added comfort. The dual motor mechanism enables the user to find their perfect comfort position.

- Stylish T Back design provides extra comfort and support
- It will rise and tilt users to their feet with ease
- Comes with a simple to operate four button handset
- Backrest can be positioned upright while legrest is elevated
- Excellent snooze position for supreme comfort and relaxation
- Two motors enable legrest to be elevated/lowered and backrest to be reclined independently



**HDA645** Memphis Armchair - Biscuit

**HDA646** Memphis Armchair - Mushroom

**HDA647** Memphis Armchair - Charcoal

**HDA648** Memphis Armchair - Berry

## Chicago Single Motor Rise & Recliner

This comfortable armchair is upholstered in easy to clean, antimicrobial PVC. Tested to BS 5852 ignition source 5 (Crib 5) making it ideal for nursing and care home environments.

- Memory foam upholstery for pressure distribution & comfort
- Excellent snooze position with backrest reclining to 64°
- It will rise and tilt users to their feet with ease
- One handset for rise and recline and another for recline only
- Safety key included in controller to prevent entrapment
- Quiet motors provide a smooth and discreet operation
- Stitched handset holder prevents loss/damage to the handset
- Ideal for those who have difficulty standing up or sitting down



**HDA641** Chicago Armchair - Anti-Microbial PVC Black

**HDA642** Chicago Armchair - Anti-Microbial PVC Cobblestone

## Nevada Dual Motor Rise & Recliner

Easy to clean chair in PVC has passed the Anti-Microbial standard ASTM G-21-96. This is a comfortable and powerful dual motor chair, tested to BS 5852 ignition source 5 (Crib 5).

- Three-tier waterfall back design provides extra support
- Memory foam upholstery for pressure distribution & comfort
- Safety key included in controller to prevent entrapment
- Includes battery back-up facility
- Memory foam upholstery for pressure distribution & comfort
- Touch 4-button hand control is user-friendly and simple to use
- Removable backrest facilitates transportation and storage
- Ergonomically contoured seat and back enhances comfort



**HDA643** Nevada Armchair - Anti-Microbial PVC Black

**HDA644** Nevada Armchair - Anti-Microbial PVC Cobblestone

## InSight Microscope Adapter

The InSight™ Microscope Adapter mounts any smartphone to any microscope in minutes!

- Smartphone camera can then capture photos and videos
- For uploading, emailing, sharing on the web and social media sites
- For real-time viewing on the smartphone screen or via video-conferencing software

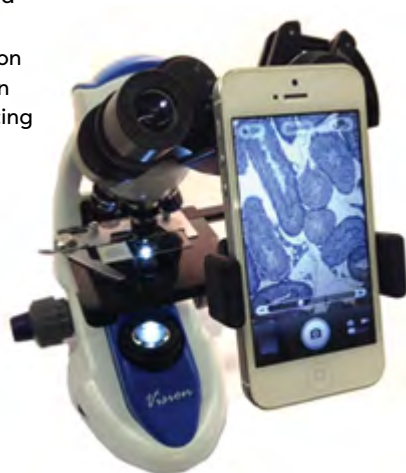

HLO055 InSight Microscope Adapter

## Vision V5000 LED Binocular Microscope

- LED illuminator with adjustable intensity – 50,000 Hr life
- Adjustable interpupillary distance and Dioptic compensation
- Revolving nose piece, quadruple, reversed
- DIN achromatic objectives 4x, 10x, 40x, 100x (60x objective available as an alternative or an addition)
- LED illuminator with adjustable intensity
- N.A. 1.25 Abbe condenser, adjustable height and iris diaphragm
- **Wide range voltage for international markets:** 100 to 240V
- Plano-concave mirror & Coaxial coarse and fine focusing
- Double layer mechanical stage, 125 x 115mm with X-Y 70 x 30mm moving range
- **Wide-field eyepieces:** 10x/18mm
- 30° inclined head rotates 360°



HLO159 Vision V5000 LED Binocular Microscope

## Vision V4002 Binocular Microscope

- **Wide-field eyepieces:** 10x/18mm
- Interpupillary adjustment 48 to 75mm
- Dioptic adjustment on left eyepiece
- 30° inclined head rotates 360°
- DIN achromatic objectives (4x, 10x, 40x, 100x)
- Variable light intensity
- LED illuminator 50,000 hours use
- Internal NiMH rechargeable battery (Up to 15 hours use from a single charge)
- N.A. Abbe 1.2 condenser
- Coaxial coarse and fine focusing
- **Double layer mechanical stage:** 125 x 116mm
- **Wide range voltage for international markets:** 100 to 240V
- Plano-concave mirror



HLO162 Vision V4002 Rechargeable Binocular Microscope

## BS200 Microscope

The laboratory Microscope BS-200 is intended for exacting analysis using bright-field transmitted light. The high-quality infinite optical system guarantees excellent image quality.

- Robust, metal stand with arm connected to the base
- Focussing by means of separate knobs for coarse and fine adjustment located on either side of the stand
- Binocular at 30° angle, rotatable through 360°, viewing distance adjustable between 50 and 76 mm, ±5 dioptic compensation for both eyepieces
- Eyepieces PL10x 18mm with infinite optics and 'high eye point'
- Inverted objective revolver with plan achromatic infinite objectives 4x, 10x, 40xS and 100xS Oil
- **Magnification:** 40x, 100x, 400x, 1000x
- **Object stage:** x-y cross table, 150 x 140 mm<sup>2</sup>, with object guide and coaxial adjustment knobs perpendicular to the object stage, adjustment range 50 x 76 mm<sup>2</sup>
- **Illumination:** Adjustable 6 V, 20 W halogen lamp, built-in transformer for 90 to 240 V mains voltage

- **Condenser:** Condenser NA1.25, iris diaphragm, focussed via rack and pinion drive
- **Dimensions:** 320 x 200 x 400 mm approx.
- **Weight:** 6.7 kg approx.
- **Accessories:** Complete with dust cover



HLO053.1 BS200 Microscope

## DARAY HL1100 LED Headlight

LED headlight designed for use in all types of surgical procedures.

The HL1100 uses LED technology alongside high quality optics transforming normal light into a clear, even and symmetrical lighting projection.

Extremely lightweight and easily adjusted, the HL1100 range can be used comfortably for long periods.

- Variable intensity
- 10W LED
- Focusable light beam
- No heat in the light beam
- 5,000K colour temperature
- Accurate view of tissue tone
- Intense, shadow-free light
- Adjustable headband
- Rechargeable battery pack
- Flight case included as standard

**HLO806** HL1100 LED Headlight with Flight Case



**DARAY**  
Medical

## HEINE® LoupeLight 2

Most trusted by dentists and ENT specialists: The combination of light and loupe delivers the ultimate in performance as high quality illumination with LED HQ maximises the image quality of the loupe.

For intensive use, the LoupeLight2 now features a replaceable connecting cord which connects the device to the mPack mini – the new and compact power source for the LoupeLight2.

- The standard in LED illumination defining optimal light intensity, homogeneity and colour rendering. Red is red, blue is blue. Colour temperature: typ. 4,000 K, Colour Rendering Index (CRI) > 90, exceptional colour rendering
- Exclusive aluminium housing protects the optics against dust and moisture to ensure an extraordinary long lifespan and optimal thermal management.
- Compact coaxial design ensures a shadow-free image and allows for excellent illumination, even for difficult to see areas.
- Polarisation filter P2 improves contrast
- Yellow filter reduces blue light.
- Replaceable connecting cord with high-quality splashproof threaded connector with a length of 1.5m. Connects the LoupeLight 2 with the mPack mini.
- Includes coloured attachment clips for personalisation to fixate the cable and to identify your LoupeLight.

**HLO781** Connecting cord SC 1 (1,5 m / Ø 2,4 mm)

**HLO788** Connecting cord SC 2 (1,5 m / Ø 3,2 mm)

**HLO774** Set with HR 2.5x/340 with i-View on S-Frame

**HLO775** Set with HR 2.5x/420 with i-View on S-Frame

**HLO776** Set with HR 2.5x/520 with i-View on S-Frame

**HLO777** Set with HRP 3.5x/420 with i-View on S-Frame

**HLO778** Set with HRP 4x/340 with i-View on S-Frame

**HLO779** Set with HRP 6x/340 with i-View on S-Frame



**HEINE** QUALITY

**LED HQ**  
LED NOW IN HEINE QUALITY.

**HLO780** LoupeLight 2 for HR/HRP Loupes with i-View Loupe mount

**HLO782** LoupeLight 2 with mPack mini and E4-USB Plug-in Transformer

**HLO193** Polarisation Filter for HR Loupes

**HLO194** Spare Polarisation Filter for HR Loupes - 2 Pairs

**HLO197** Detachable Yellow Filter

**HOP1406** mPack mini with Li-on recharge battery & E4-USB transformer

**HOP1407** mPack mini with Li-on recharge battery only

**HOP1408** mPack mini Belt Clip

**HOP1409** USB cord & E4-USB transformer

**HOP1410** E4-USB - Medical approved plug-in power supply for USB cord

## HEINE® HR 2.5x Binocular Loupe

Your optimal loupe is as individual as your work. HEINE's HIGH TECH optics offer a large variety of loupes to fulfill your individual needs. Experience the difference of getting less tired - even during long procedures.

- Chromatic optics for bright images with colour-correction
- Lightweight and easily portable at just 51g
- Product is water-resistant
- Independent adjustment of optics for perfect PD adjustment
- High magnification with a large field of view and excellent depth of field.
- i-View loupe mount provides any angle of view and flips up the optics independently of the optional LoupeLight 2.
- Set comprises of HR 2.5 x optics with i-View on S-FRAME, Protective lenses, 2 steriliser swivel levers, Retaining cord, Cleaning fluid, Cleaning cloth, Carrying case

**HLO181** HR 2.5x - Working distance: 340mm

**HLO182** HR 2.5x - Working distance: 420mm

**HLO183** HR 2.5x - Working distance: 520mm

**HEINE** QUALITY

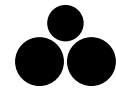

**LIGHT  
WEIGHT**

COAXIAL  
ILLUMINATION

LIGHTWEIGHT  
FRAME



## HEINE® LED MicroLight 2

Two mounting options offer individuality and easy handling. For a perfect view and a precise diagnosis, the MicroLight2 is now 25% brighter than its predecessor model, with a homogeneous edge-to-edge illumination.

For intensive use, the LoupeLight2 now features a replaceable connecting cord which connects the device to the mPack mini – the new and compact power source for the MicroLight2.

- The standard in LED illumination defining optimal light intensity, homogeneity and colour rendering. Red is red, blue is blue. Colour temperature: 4,000 K, Colour Rendering Index (CRI) > 90
- Compact and lightweight ensuring perfect comfort.
- Exclusive aluminium housing protects the optics against dust and moisture to ensure an extraordinary long lifespan and optimal thermal management.
- Coaxial illumination: Compact coaxial design ensures a completely shadow-free image and allows for excellent illumination of difficult to see areas.
- Yellow filter reduces blue light.
- An absolutely bright light spot that is uniform from edge-to-edge for the perfect illumination in all examination situations.
- Replaceable connecting cord with high-quality splash-proof threaded connector with a length of 1.5m. Connects the MicroLight 2 with the mPack mini.
- Includes coloured attachment clips for personalisation. To fixate the cable on S-FRAME and identify your headlight.

**HLO785** MicroLight 2 on Lightweight Headband with mPack mini, mPack Belt Clip, E4-USB transformer & case

**HLO784** MicroLight 2 on S-FRAME with mPack mini, mPack Belt Clip, E4-USB transformer, retaining cord, cleaning fluid & case

**HEINE** QUALITY

**LED HQ**  
LED NOW IN HEINE QUALITY.



**HLO784**



**HLO785**

**HOP1406** mPack mini with Li-on recharge battery & E4-USB transformer

**HOP1407** mPack mini with Li-on recharge battery only

**HOP1408** mPack mini Belt Clip

**HOP1409** USB cord & E4-USB transformer

**HOP1410** E4-USB - Medical approved plug-in power supply for USB cord

**HLO781** Connecting cord SC 1 (1,5 m / Ø 2,4 mm)

**HLO788** Connecting cord SC 2 (1,5 m / Ø 3,2 mm)

**HLO197** Detachable Yellow Filter

## HEINE® ML4 Headlight Headlight

- The new standard in LED illumination defining optimal light intensity, homogeneity and colour rendering.
- Adjustable illumination spot size: 30mm–80 mm spot size range (at 420mm working distance) to fit any situation
- Bright and Homogenous Illumination. Absolutely bright light spot that is uniform from edge-to-edge for the perfect illumination in all examination situations.
- Stepless light intensity control. Optimal brightness setting prevents reflexes.
- Flexibility. Flexible Power Source Options: 100% mobility with a choice of cable-free mPack UNPLUGGED head-worn battery or mPack belt worn battery pack.
- Coaxial design ensures a completely shadow-free image and allows for excellent illumination of difficult to see areas.
- Comfortable and secure fit with adjustable headband and soft padding for comfort and stability – even during long use.
- Polarisation filter P2 improves contrast and yellow filter reduces blue light

<b>HLO189</b>	Detachable Yellow Filter
<b>HLO203</b>	Polarisation Filter P2 for ML4 LED and HR Loupes
<b>HLO194</b>	Spare Polarisation Filter for HR Loupes - 2 Pairs
<b>HLO190</b>	Extension Cord from plug-in transformer UNPLUGGED to mPack UNPLUGGED, 2m

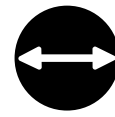

CONTINUOUS ADJUSTMENT



FLEXIBLE POWER SOURCE



COMFORT AND ERGONOMICS

**LED HQ**  
LED NOW IN HEINE QUALITY.



<b>HLO198</b>	ML4 LED Headlight without power source
<b>HLO199</b>	ML4 LED Headlight with plug-in transformer
<b>HLO200</b>	ML4 LED Headlight with mPack & plug-in transformer
<b>HLO201</b>	ML4 LED Headlight with mPack UNPLUGGED & transformer
<b>HLO202</b>	ML4 LED Headlight with Wall mounted charger and 2x mPack UNPLUGGED

## Peli VB3™ LED 2220Z1 III LED

- **Colours:** Black or Yellow
- **Light Source:** 2 x 5mm White Nichia LEDs
- **Tested Lumen Value:** 9
- **Beam distance:** 12 metres
- **Candelas:** 38
- **Battery Burn Time:** 34 hours
- **Length:** 89mm
- **Weight with batteries:** 30g
- **ATEX Approvals:** II 2 G Ex ib op is IIC T6 Gb
- **Batteries:** 2 x CR2032 3V Lithium coin-cell (included)

<b>HEL035</b>	Peli VB3™ LED 2220Z1
---------------	----------------------

- Head flips up to activate LEDs and rotates 180° for aiming light where you need it
- Body made of virtually indestructible Xylex®
- Multiple use built in clip
- Attaches to surface up to 10mm thick
- Excellent battery efficiency



## Peli 2690 Zone 0 HeadsUP Lite™ LED

- Easy twist bezel switch for gloved hand operation
- 90° pivoting head directs the light where required
- Compact, lightweight LED headlamp
- Atex Mining Group 1 certified
- Waterproof (IPX7) to 1 metre
- **Weight with batteries:** 120g
- **Atex Approval:**  
I M1 Ex ia I Ma, II 1 G Ex ia IIC T4 Ga,  
II 1D Ex ia IIIC T65°C Da
- **Batteries:** 3 x AAA Alkaline (included)
- **Battery Burn Time:** 11 hours
- **Beam distance:** 92m
- **Tested Lumen Value:** 74
- **Candelas:** 2124
- **Length:** 71mm



<b>HEL105</b>	Peli 2690 Zone 0 HeadsUP Lite™ LED
---------------	------------------------------------

## Peli 2610 Zone 0 HeadsUP Lite™ LED

- Push button switch
- Includes both a rubber strap and a cloth strap
- Rugged ABS Body
- **Dual mode LED headlight:** 1 LED (Low) or 3 LEDs (High)
- **Weight with batteries:** 91g
- **Atex Approval:** II 1 G Ex ia op is IIC T4 Ga
- **Batteries:** 3 x AAA Alkaline (included)
- **Battery Burn Time:** 47hrs (Low) / 19hrs. (High)
- **Beam distance:** 19m (Low) / 28m (High)
- **Tested Lumen Value:** 14 (Low) / 30 (High)
- **Candelas:** 91 (Low) / 194 (High)
- **Length:** 38mm



<b>HEL106.2</b>	Peli 2610 Zone 0 HeadsUP Lite™ LED
-----------------	------------------------------------

## Philips InnoSpire Deluxe Nebuliser

An easy to use and reliable compressor nebuliser system that includes built-in storage to keep all your therapy accessories and supplies organized and handy.

- Designed to make your nebuliser treatment convenient and easy, with added built-in storage to house all your accessories.
- Robust enough for continuous use in both a clinical and family environment, provides consistent and reliable therapy.
- Light enough to pick up and move from room to room at home. With your supplies stored neatly away within the device, your nebuliser equipment stays safely together.
- Capable of nebulising a wide variety of medications that are routinely used to treat various respiratory conditions.

**Size:** 13" x 6.7" x 4.3"

**Weight:** 2.0Kg

See further SideStream options on the next page

**HRS107.2** Medix AC2000 Nebuliser Unit



**PHILIPS**  
**RESPIRONICS**



3 Year  
Warranty



## Philips InnoSpire Essence Nebuliser

When reliability is key choose InnoSpire Essence. Provides fast, efficient nebulized drug therapy for you and your family at home.

Designed for intermittent use and suitable for the home, consistent delivery of high-quality aerosol treatment. Combined with the SideStream Nebulizer, is designed to provide fast drug delivery and short treatment times.

- Compact home-use device
- Partnered with proven SideStream technology
- Short treatment times in 6 – 8 minutes
- Fast but effective treatment
- Nebulizer kit included
- 3 year warranty

**Size:** 6.5" x 6.5" x 4.3"

**Weight:** just 1.5kg

See further SideStream options on the next page

**HRS879** InnoSpire Essence with disposable SideStream

**HRS879.2** InnoSpire Essence Inlet Filters (4 Pack)

## Philips InnoSpire Mini Nebuliser

InnoSpire Mini allows your patients to nebulize their medications whenever they want and wherever they may be. Compact, lightweight and reliable, it provides independence for people who want to get the most out of life.

An ideal traveling companion, InnoSpire Mini's compact size allows for easy transport while a breath-enhanced reusable nebulizer makes it easy to use.

- Compact portable device
- Partnered with proven SideStream technology
- Operates for up to 90 minutes between charges
- Fully recharged in around 6 hours
- Nebulizer kit included
- FAA approved for in-flight use

**Size:** 4.5" x 3.5" x 2.1"

**Weight:** only 0.5kg

See further SideStream options on the next page



**HRS880** InnoSpire Mini with SideStream Plus (No filter or hose incl.)

**HRS880.1** InnoSpire Mini Inlet Filters (4 Pack)

**HRS880.3** InnoSpire Mini AC power lead (UK)

**HRS880.4** InnoSpire Mini Rechargeable Lithium Battery

## Philips Disposable SideStream

The disposable SideStream is inexpensive, and can be used for up to 2 weeks. A handheld nebuliser great for travel or using at the office, designed to aerosol approved medication.

SideStream's venturi system enhances output (80% of drug output volume is below 5 microns in size). It also speeds up treatment time by using five jet holes instead of one, providing additional flow of up to 16 lpm above compressor output.

**PHILIPS**  
RESPIRONICS



**HRS881** Disposable SideStream (50 Pack)

**HRS880.1** Disposable SideStream, Adult Mask + Tubing (50 Pack)

**HRS881.2** Disposable SideStream, Child Mask + Tubing (50 Pack)

**HRS881.3** Disposable SideStream, Mouthpiece + Tubing (50 Pack)

## Philips Reusable SideStream

The reusable SideStream has a long life, requiring replacement after 6 months. A handheld nebuliser great for travel or using at the office, designed to aerosol approved medication.

SideStream's venturi system enhances output (80% of drug output volume is below 5 microns in size). It also speeds up treatment time by using five jet holes instead of one, providing additional flow of up to 16 lpm above compressor output.

**PHILIPS**  
RESPIRONICS



**HRS882** Reusable SideStream (50 Pack)

**HRS882.1** Reusable SideStream, Adult Mask + Tubing (Single)

**HRS882.2** Reusable SideStream, Child Mask + Tubing (Single)

**HRS882.3** Reusable SideStream, Mouthpiece + Tubing (Single)

## Philips SideStream Plus

Philips SideStream Plus breath-enhanced, reusable nebuliser is designed to improve drug delivery. Much less pressure is needed to open the inspiratory valve compared to other breath-enhanced nebulisers. For faster, easier treatment.

Provides fast, effective treatment and can be used to effectively deliver most commonly prescribed aerosol medications. Features an easy-action inspiratory valve that opens on inspiration to boost medication delivery and closes on exhalation, preserving medication and reducing waste.

Significantly less pressure is needed to open the inspiratory valve, making it ideal for weak breathers, such as paediatric and elderly patients.

- Works with all Philips compressor systems
- Fits under mask for extra convenience
- Easy action inspiratory valve boosts drug delivery

**HRS883** SideStream Plus expiratory filter holder + 10 pads

**HRS883.1** SideStream Plus with expiratory filter holder + 10 pads

**HRS883.2** SideStream Plus with valved mouthpiece only

**HRS883.3** SideStream Plus with aerosol ventilation hose



**PHILIPS**  
RESPIRONICS

**HRS883**

**HRS883.1**

**HRS883.2**

**HRS883.3**



## Medix AC2000 Nebuliser

Powerful enough to nebulise all commonly prescribed medications for chronic chest conditions

- Mains powered - can be used in all European countries
- Self cooling motor allows the AC2000 to be kept on for an unlimited period of time
- Supplied with starter pack for adult and child giving a three month supply of accessories.
- Ideal for home and clinic use - this reliable unit is easy to use
- Large internal compartment to store accessories & medication
- Flow rate 7-9 Litres per minute at 20psi/138kpa
- Three year comprehensive guarantee from UK manufacturer on motor and needs to be serviced once a year
- **Weight:** 4kg



HRS107.2 Medix AC2000 Nebuliser Unit

## Econoneb

Econoneb is continuously rated, making it a cool running nebuliser for demanding use. This reliable and durable unit is ideal for meeting the challenges of hospital or at home

- Attractive design, easy to use controls, and top carrying handle makes this a popular choice with all age groups
- High flow rate which is suitable for nebulising bronchodilators (relievers), corticosteroids (preventers) and antibiotics
- Supplied with starter pack for adult and child giving a three month supply of accessories.
- Three year comprehensive guarantee from UK manufacturer on motor and needs to be serviced once a year
- **Typical Dynamic Flow & Pressure:** 7-9 L/min at 20psi/138kpa
- **Nebulisation Time:** 2.5 - 5.5 min for 2.5ml
- **Weight:** 4 Kg



HRS187 Econoneb Nebuliser Unit

## Medix Year Packs

Available as a child or adult pack, each Medix Year Pack contains all disposable items that are required by Medix nebulisers during a 12 month period. These items ensure efficient delivery of all medication and provide the user with the reassurance of having replacements available when needed for a great price.

- 1x Mouthpiece
- 4x Masks
- 1x Outlet Filter
- 4x Inlet Filters
- 4x Medication Chambers
- 4x Drive Line Tubes



HRS065 Medix Year Pack - Adult

HRS066 Medix Year Pack - Child



HRS723 Airmed 1000 unit

HRS724 Airmed 1000 Adult Year Pack

HRS725 Airmed 1000 Child Year Pack

## Airmed 1000

An inexpensive option for a powerful compact compressor that efficiently treats asthma, allergies and other respiratory conditions; suitable for patients of all ages.

- Comes complete with a starter pack (See below for contents)
- Continuously rated whilst compact and lightweight
- Easy carrying handle and optional travel bag is also available
- Reliable performance with a 2 year guarantee
- **Weights:** 1.38kg
- **Respirable output:** MMAD 4 microns
- **Operates from:** 230v mains
- **Avg nebulisation rate:** 0.2ml/min
- **Litre flow range:** 4-8L/min
- **Nebulises 2.5ml in:** 12.5 minutes
- **Starter pack contents:**  
1 x Adult/Child Facemask, 1x Driveline,  
1 x Mouthpiece and 5 inlet filters

## Airmed Travel-Air

A portable compact compressor, designed to efficiently deliver prescribed medication to the bronchial lung passages. Lightweight design makes the Travel-Air nebuliser ideal for portable use.

- Comes complete with a starter pack (See right for contents), and universal AC adapter ready for immediate use
- Includes rechargeable battery and travel bag
- Can be used with mains, as well as being battery operated
- Simple one button operation which can be used worldwide
- **Optional extras:** Extra rechargeable battery / Car adapter
- **Weighs:** 395g without battery and 712g with battery
- **Respirable output:** MMAD 4 microns
- **Operates from:** 240v mains (with AC adapter)
- **Battery using time:** 45 minutes
- **Average nebulisation rate:** 0.2ml/min
- **Litre flow range:** 5.0-6.7L/min
- **Nebulises 2.5ml in:** 12.5 minutes



### Starter pack contents:

1 x Adult/Child Facemask, 1x Driveline, 1 x Mouthpiece and 5 inlet filters



**HRS718** Airmed Travel-Air

**HRS719** Airmed Travel-Air Adult Year Pack

**HRS720** Airmed Travel-Air Child Year Pack

**HRS721** Car Adapter

**HRS722** Spare Rechargeable Battery

## Nebuliser Disposable Masks & Spares

Replacement disposable masks and items required by nebulisers to ensure efficient delivery of all medication.



**HRS112** Nebuliser Chamber (each)

**HRS115** Drive Line Tube (each)

**HRS116** Adult Face Mask (each)

**HRS117** Paediatric Face Mask (each)

**HRS114** Mouthpiece (each)

## Disposable Nebuliser Kits & Mouthpieces

Replacement disposable nebulisers kits and user mouthpiece packs.

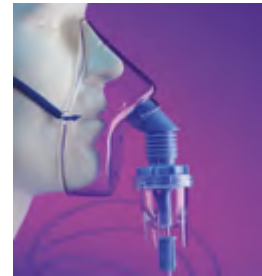

**HRS126** Adult Face Mask Nebuliser Kit (each)

**HRS127** Adult Face Mask Nebuliser Kit (Box of 25)

**HRS128** Paediatric Face Mask Nebuliser Kit (each)

**HRS129** Paediatric Face Mask Nebuliser Kit (Box of 25)

**HRS114** Mouthpiece (each)

## Omron DuoBaby

OMRON DuoBaby is a unique 2-in-1 compressor nebulizer with a nasal aspirator. Specifically designed to alleviate nasal congestion and treat respiratory conditions, the DuoBaby provides dual treatment for the respiratory care for babies.

With DuoBaby, you can ensure a smooth recovery from respiratory conditions for your baby.

The DuoBaby is equipped with an innovative nasal aspirator, designed to gently remove mucus. Clinically proven, nasal aspiration can unblock the nose and reduce the risk of further lung infections in babies.

- **2-in-1:** Compressor nebulizer and nasal aspirator in one device
- **Alleviates congestion:** Removes mucus to clear a blocked nose
- **Reduces risk of lung infections:** Prevents further lung infections through nasal aspiration
- **Suitable for upper and lower airways conditions** Efficiently delivers medication to upper and lower airways
- **Hygienic** No need for an anti-bacterial filter
- **Washable** Fully washable with no disposable parts



**OMRON**



**HRS756** Omron DuoBaby Unit

**HRS757** DuoBaby Nebulizer Accessory Set

**HRS758** Omron Air Filter Set

## Omron CompA-I-R™ NE-C28P

The unique combination of the OMRON CompA-I-R™ Compressor with the Virtual Valve Technology (V.V.T.) means more of the aerosol is a respirable size and available to the patient to inhale.

The V.V.T.'s unique design means there are fewer parts to lose, less parts to clean. Higher hygiene and simple maintenance.

### Product Includes:

V.V.T nebuliser chamber, Mouthpiece, Adult/child masks, Tubing with easy to attach connectors and spare filters, Carry bag

- High respirable output from new V.V.T nebuliser chamber
- Simple to use and easy to clean case
- 3 year guarantee
- Water resistant switch
- **Weight:** 1.9kg



**HRS256** CompA-I-R™ NE-C28P Nebuliser

**HRS258** Inlet filters (pack of 5) for CompAir

**HRS259.1** VVT C28P boilable nebkit and mouthpiece

**HRS260** Nebuliser Kit

## Omron MicroAIR U100

The MicroAIR U100 Nebulizer is efficient, silent, and fits easily into your bag—so your whole family can breathe easy, wherever life takes you.

Now relief is at your fingertips, even when you're on the road. The battery-operated MicroAIR U100 is compact, travel-ready and easy to reach for whenever you need it.

While traditional nebulizers can be loud, the MicroAIR U100 is virtually silent.

The MicroAIR U100 helps deliver efficient treatment, whether you're lying down, standing up, or dangling upside-down from monkey bars. The U100 works at a position comfortable for you.

The MicroAIR U100 uses a unique mesh technology that delivers more medication into the lungs compared to most compressor nebulizers.



**HRS316** Omron MicroAIR U100

## AirForce One Nebuliser

The AirForce One compressor nebulizer is a cost effective and reliable device for aerosol therapy at home or in hospitals. Compact, lightweight with a quiet operation, it fits into home and clinical settings discreetly.

Engineered with the patient in mind, the quality, easy-to-use features offer an effective yet simple drug delivery option.

- Only weighing 1.5kg AirForce One is the lightest compressor nebulizer in the Drive DeVilbiss range
- Designed to be durable for everyday use and comes with a
- Built in carrying handle for added convenience
- Offering a maximum flow rate of 5.1l/min
- Includes necessary accessories ready for immediate use

### UK version comes with a Disposable nebuliser kit

Containing an instruction manual, disposable Evo nebulizer, nose piece, mouthpiece with exhalation valve, air tubing, adult and paediatric mask and five filters.



**HRS159** Drive DeVilbiss AirForce One Nebuliser

## HOSPYNEB Professional Nebuliser

Piston compressor nebuliser for home/clinic use. Intended to be used for inhaling medication for respiratory disorders.

- Made in Italy
- Noise Level: 60 db
- Max Pressure: 350 Kpa (3.5 bar)
- Operating Pressure: 0-130 Kpa (0-1.3 bar)
- NEB Rate: 0.35 ml/min (60kPa) / ÷ 0.80 ml/min (130kPa)
- Air Flow: 15 ltr/min
- Capacity: 16ml
- Operating Cycle: Continuous
- Respirable Volume: < 5 µm 80%
- MMAD\*: 2.11 µm
- Residual Volume: 0.7ml
- Weight: 4.1kg

**includes:** Nosepiece, Mouthpiece with Silicone Valve, Adult Mask (PVC Deph Free), Child Mask (PVC Deph Free), Air Tube (PVC Deph Free), Spare Filter and Power Cord



**3A HEALTH CARE** is an OMRON Healthcare Europe company

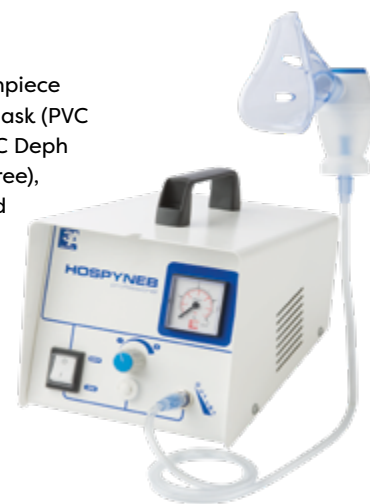

**HRS870** HOSPYNEB Pro Nebuliser

## Stalham 150 Lifting Hoist

Capable of lifting patients of almost any build, assisting with patient transfer from chairs, toilets and other areas.

A large selection of slings are available to fit this hoist, designed for a variety of scenarios and users.

### Structure

- Epoxy coated steel frame
- Complete lifting hoist can be assembled in just a few minutes
- Utilises electric lifting arm

### Comfort

- A range of comfortable slings are available to fit patients
- Ergonomic handles.

### Ease Of Handling

- Wired remote control for user controls in any position around the lift.
- Capable of lowering patient to the ground.
- The base frame has a very low construction to allow for very good under-ride possibilities.
- Base legs expand as needed by means of foot pedal.
- Mounted on four swivelling castors for portability.
- Each rear castor is braked.

### Safety

- Features easy to access emergency stop button.
- Lift can allow for emergency mechanical lowering if required.
- Additional battery backup.
- Medical grade electric lifting arm.

**STALHAM**  
By Medi-Plinth

 Made in the UK

 Free Delivery

### Specifications

- Lift height (min.): 55 cm
- Lift height (max.): 174 cm
- Underpin height: 14 cm
- Device weight: 43 kg
- Maximum user weight: 150 kg



**HDA016** Medi-Plinth Stalham 150 Lifting Hoist

## Stalham Lifting Slings

### Stalham Toileting sling

- Designed for use with the Stalham Lifting Hoist
- Approved up to 250 kg



### Universal patient sling

- Sizes: Small to XL/XXL
- Designed for use with the Stalham Lifting Hoist
- Approved up to 250 kg



### Stalham Net/bath sling

- Available: S, M/L or XL/XXL
- Designed for use with the Stalham Lifting Hoist
- Approved up to 250 kg



### Stalham Bariatric Sling

- Designed for use with the Stalham Lifting Hoist
- Approved up to 300 kg



**HDA018.1** Stalham Hoist Toilet Sling with Velcro Fastener Size M

**HDA018.2** Stalham Hoist Toilet Sling with Velcro Fastener Size L

**HDA018.3** Stalham Hoist Toilet Sling with Velcro Fastener Size XL

**HDA021** Stalham Hoist Net/Bath Sling - Small (without reinforcement)

**HDA021.1** Stalham Hoist Net/Bath Sling - M/L

**HDA021.2** Stalham Hoist Net/Bath Sling - XL/XXL

**HDA019** Stalham Hoist Universal Sling - Small (without reinforcement)

**HDA019.1** Stalham Hoist Universal Sling - Medium (without reinforcement)

**HDA019.2** Stalham Hoist Universal Sling - XL/XXL

**HDA019.3** Stalham Hoist Universal Sling - M/L

**HDA019.4** Stalham Hoist Universal Sling - M/L with Headrest

**HDA020** Stalham Hoist Bariatric XL Sling

## Stalham Hoist Spreader Bar

- Wide Spreader Hanging bar for Stalham hoist
- 4-point spreader bar for use with the Stalham Lifting Hoist
- Dimensions: 56 x 33 x 14cm



HDA022 Stalham Hoist Four Point Spreader Bar (Wide Hanger)

## Stalham Hoist Scale PW600

- Integrate with Stalham scale to provide accurate weight measurements
- For use with the Stalham Lifting Hoist
- Approved to class III, MPG class I



HDA023 Stalham Hoist Scale PW600

## Stalham 150 Sit-to-Stand Hoist

Capable of lifting patients from a sitting to a standing position with safety and ease. Further accessories are available for comfort and stability. Designed for use with disabled or limited mobility, in a range of environments.

### Structure

- Epoxy coated steel frame
- Complete lifting hoist can be assembled in just a few minutes
- Utilises electric lifting arm

### Comfort

- Leg strap available to ensure comfort and stability for patient.
- 180° grab handles support patient.
- Angled foot rests secure feet in place when in use..

### Ease Of Handling

- Wired remote control for user controls in any position around the lift.
- The base frame has a very low construction to allow for very good under-ride possibilities.
- Undercarriage is expandable as needed by means of foot pedal.
- Mounted on four swivelling castors for portability.
- Each rear castor is braked.

### Safety

- Features easy to access emergency stop button.
- Lift can allow for emergency mechanical lowering if required.
- Additional battery backup.
- Medical grade electric lifting arm.

HDA017 Medi-Plinth Stalham 150 Sit-to-Stand Hoist

### Specifications

- Lift height (min.): 84 cm
- Lift height (max.): 150 cm
- Underpin height: 14 cm
- Device weight: 53 kg
- Maximum user weight: 150 kg

**STALHAM**  
By Medi-Plinth



Made in the UK



Free Delivery



## Stalham Lifting Hoist Calf Strap

Designed to add support, stability and comfort for the patient when lifting from sit to stand position



HDA025 Stalham Lifting Hoist Calf Strap

## Stalham Lifting Hoist Backsling

- Available in sizes: Medium to XXL
- Helps with patient stability and comfort when lifting



HDA024 Stalham Lifting Hoist Backsling - M/L

HDA024.1 Stalham Lifting Hoist Backsling - XL

HDA024.2 Stalham Lifting Hoist Backsling - XXL

## Liko™ M230 Mobile Lift

Features an intuitive design that makes the lifts very easy to use. Coupled with a wide range of slings and accessories, the lift creates a secure and comfortable lifting experience for users and patients. Fully electric, including the base-width adjustment.

- Meet all of the most common lifting needs, including lifting from the floor. A long lifting arm provides easier access to patients situated in the centre of a bed.
- A low base clearance of 105 mm fits easily under most beds
- The battery can be charged while on the lift or easily removed for external wall-charging
- Base-width adjustment on the M230 is electrically operated to allow easy access around chairs or other furniture.
- The long lift arm allows for easy patient rotation and easily lifting the patient to the centre of the bed.
- An easy-to-use lifting solution with intuitive hand controls

**Maximum Load:** 182 kg

**Size (Height x Width):** 1335 – 1900mm x 670 – 1030 mm

**HCF021** Liko™ M230 Mobile Lift

**Baxter**



**Baxter**



## Golvo™ 9000 Mobile Lift

Offers the functional advantages of an overhead lift with the flexibility of a mobile lift. With an extensive range of Liko accessories, Golvo is ideal for common lifting situations.

- Vertical lifting motion with flexible lift strap is ideal for horizontal lifting, ambulation and lifting from the floor
- Parallel base-width adjustment contributes to easier lifting of patients or residents to/from chairs, beds and the floor
- LowBase version allows for even greater clearance under low beds or stretchers versus the standard model
- Armrests help to support patients during ambulation, as well as making it easier for caregivers to maneuver the lift
- User display highlights device usage, including lift count, service required indicator and overloads

**Maximum Load:** 200 kg

**Height:** 2090 mm

**HCF024** Golvo™ 9000 Mobile Lift

## Liko Uno 102 Lift

The basic principles behind the design of the Uno™ 102 are well established and well tested. Liko® has developed the principles and has equipped Uno with many good features.

Uno is the ideal lift for day-to-day use. It's easy to use and manoeuvre, enabling convenient access even in bathrooms where space is limited.

- Uno's smart FlexLink (an extra link arm increasing the distance to the lift mast) provides for almost vertical lifting motion and greater flexibility when lifting from the floor.
- With its three different height settings, Uno can be easily adapted to different transfer situations
- Manual and electric emergency lowering mechanisms ensure safe operation for caregivers
- The compact design offers a greater range of access for lifting throughout the home and care facilities

**Maximum Load:** 175 kg

**Adjustable Height:** 1435 to 2015 mm

**HCF023** Liko Uno 102 Patient Lift

**Baxter**



## Viking™ M Patient Lift

Designed to safely move a patient without injury, either to staff or to the patient. This durable aluminium lift handles loads up to 205 kg (452 lb) despite its low weight.

The refined aluminium design provides low weight and high durability. The weight-to-capacity ratio makes the Viking M lift easy to manoeuvre, while features such as two lifting speeds and immediate charge status notification offer added convenience.

Equipped with an intelligent diagnostic system that alerts when lift is ready to use and when it is time for service. The lightweight, environmentally-friendly battery is easy to charge and handle.

- The smart FlexLink (an extra link arm increasing the distance to the lift mast) provides for almost vertical lifting and greater flexibility when lifting from the floor.
- With Liko Quick Release Hook System a sling bar or other lifting equipment can be changed quickly and easily.

**Maximum load:** 205 kg

**Adjustable Height:** 1340 - 2020 mm

**Baxter**



**HCF022** Viking™ M Patient Lift

## Viking™ XL Patient Lift

Transferring heavy patients is a great responsibility. The Viking™ XL was developed for bariatric patients but also fits smaller users.

The lifting capacity of 300 kg (660 lb) and the large interval make Viking XL ideal for all heavy lifting, including lifting from floor and gait training. Other common application areas are horizontal lifting and lifting to/from a bed or wheelchair.

- Viking XL weighs only 43 kg (95 lb) and is very easy to handle
- The smart FlexLink (an extra link arm increasing the distance to the lift mast) provides for almost vertical lifting and greater flexibility when lifting from the floor.
- Two lifting speeds accommodate a variety of lifting situations
- User display highlights device usage, including lift count, service required indicator and overloads

**Adjustable Height:** 1500 to 2110 mm

**HCF022.1** Viking™ XL Patient Lift

**HCF029** UniversalSling™

**Baxter**



## Sabina™ II Mobile Lift

Sabina II lift meets the needs of a wide range of patients by offering the ability to adapt each raising or lifting operation to the capabilities of the individual patient. Its cleverly engineered accessories provide several unique application opportunities.

- Adjustable height levels accommodate patients of most sizes. The lift may also be used as a conventional patient lift for lifting in the sitting position.
- Easily exchangeable sling bars to ensure patient comfort and efficient lifting, including options to lift outside of the arms and around the upper body.
- The Sabina II lift has adjustable height levels to support a variety of patient sizes and conditions.
- Base-width adjustment offers greater flexibility of use when lifting from a bed or chair, enhancing patient mobility
- Powerful lifting motor ensures the smooth raising and lowering of patients

**Maximum Load:** 200 kg (active lifting) / 150 kg (passive)

**HCF025** Sabina™ II Mobile Lift

**Baxter**



**See SafetyVest & SupportVest lift aids**



## Viking™ L Patient Lift

Designed to safely move a patient without injury, either to staff or the patient. Durable aluminium lift handles loads up to 250kg. The aluminium design offers low weight and high durability.

Two lifting speeds and charge status notification offer added convenience. Equipped with an intelligent diagnostic system that alerts when lift is ready to use and when a service is required. The lightweight, environmentally-friendly battery is easy to charge.

- The smart FlexLink (an extra link arm increasing the distance to the lift mast) provides for almost vertical lifting and greater flexibility when lifting from the floor.
- With Liko Quick Release Hook System a sling bar or other lifting equipment can be changed quickly and easily.
- Optional armrests support patients whilst they walk
- Range of accessories to help you adapt lift for different needs

**Maximum load:** 250 kg

**Adjustable Height:** 1340 - 2020 mm

**Maximum lifting height:** 1790mm

**HCF022.2** Viking™ L Patient Lift

## Liko™ M220 Mobile Lift

Features an intuitive design that makes the lifts very easy to use. Coupled with a wide range of slings and accessories, the lift creates a secure and comfortable lifting experience for patients.

- Incorporates a manually adjustable base
- Meet all of the most common lifting needs, including lifting from the floor. A long lifting arm provides easier access to patients situated in the centre of a bed.
- A low base clearance of 105 mm fits easily under most beds
- The battery can be charged while on the lift or easily removed for external wall-charging
- The long lift arm allows for easy patient rotation and easily lifting the patient to the centre of the bed.
- Easy-use solution with intuitive hand controls (wired 2 button)
- The compact design offers a greater range of access for lifting throughout the home and care facilities

**Dimensions:** 1335 – 1900mm x 670 – 1030 mm

**Maximum Load:** 182 kg

**Maximum Lifting Height:** 1725mm

**HCF021.1** Liko™ M220 Mobile Lift



## Liko LiftPants Ambulation Aid

Liko LiftPants sling facilitate safe and secure standing- and gait training for patients with poor balance and leg function, giving them the confidence to take new steps.

- Net Polyester, padded
- Available in S,M,L and XL
- Max load 500kg (1100lbs).
- Includes two piece Loop Clips

**HCF034** Liko LiftPants – Polyester Net Padded





## SafetyVest™ Lift Aid

A sit-to-stand vest designed to assist patients with poor stability who have difficulty standing steadily. For such patients, the use of appropriate tensioning devices can provide adequate security.

The SafetyVest lifts in a way that is self-regulating and very safe—so that both patient and caregiver feel secure. The vest is padded with a fabric that provides a high degree of friction and effectively prevents gliding.

- SafetyVest is available in several sizes, but the individual fitting is just as important as choosing the right size.
- SafetyVest is padded with a fabric which provides a high degree of friction that effectively prevents gliding.



**Baxter**

HCF026 SafetyVest™ Lift Aid

## SupportVest™ Lift Aid

Used with Sabina sit-to-stand lift. The SupportVest is a comfortable sling which lifts behind the back and under the arms. Easy to use and requires minimal individual adjustment.

SupportVest's soft padding distributes pressure evenly and comfortably. The belt holds the SupportVest in place around the body during the first stage.

Available in different sizes and is used in combination with Sabina® sit-to-stand lift with narrow sling bar.



**Baxter**

HCF031 SupportVest™ Lift Aid

## UniversalSling™

Easy to apply and remove, and, if the right size is selected, it adapts to the patient's body without individual adjustments.

Liko UniversalSling offers comfort and security in lifting for both patient and caregiver. Its suitable for most lifting situations which makes it a good choice when caregivers are uncertain about which patient is going to be lifted.

Designed to support the entire back and keeps the patient's arms held inside the sling. Correctly fitted and properly applied, the sling provides the patient with a sense of security and comfort.



**Baxter**

HCF029 UniversalSling™

## Universal UltraSling™ Lift Aid

Liko has developed the Ultra product series to help lift heavy patients in a safe and comfortable manner.

UltraSling™ is used for lifting sitting patients. The system can have a max load of up to 500kg, depending on which products are included in the lift unit.

UltraSling supports the entire back up to the shoulders. With the UltraSling's unique design, the leg supports are installed individually on the sling bar, which gives the stomach space and the legs optimal support.



**Baxter**

HCF029.1 Universal UltraSling™

## Original HighBack Sling

The Original HighBack (m20) and Soft Highback (m26) Slings, are Hillrom's most popular slings. Both models provide comfortable, whole-body support suitable for most patients.

The sling design offers a reclined sitting posture for patients with poor head and trunk stability. M26 is an advanced development of M20 and features a pliable "soft plate" for comfortable support needed when lifting from the recumbent position.

Both models have separated leg supports to ensure that the patient does not sit on the sling after use. Instead, the sling is easily removed from the chair after the transfer. Both the 20 and 26 models are recommended for lifting to and from the floor.

HCF030 Original HighBack Sling

HCF030.1 Soft Original HighBack Sling

**Baxter**

HCF030



HCF030.1

## Liko HygieneVest™

Designed for safe and comfortable transfers to and from the toilet. The vest offers almost fully upright sitting, and provides functional and safety advantages. Works well in complicated situations, such as when lifting amputees or patients with poor muscle tone.

The vest section firmly supports the upper body during transfer, while a generous opening around the buttocks leaves the lower body free for dressing and undressing during toilet visits.



**Baxter**

HCF027 Liko HygieneVest™

## MasterVest™ Lift Aid

A versatile lifting aid that facilitates toilet visits, standing training, gait training, mobility training – placing patients into standing positions using aids.

Manual lifting and transferring to and from the toilet can be accomplished easily and smoothly.

The vest lifts around the upper body and partly under the arms, best suited for patients that can support some of their body weight with legs and feet. A design that leaves the lower body free for dressing and undressing.



**Baxter**

HCF032 MasterVest™ Lift Aid

## FreeSpan™ Gantry Lift System

A freestanding system can be used instead of a fixed overhead lift installation, allowing you to use an overhead lift without having to make alterations to the room. It offers an ideal solution when the lifting need is temporary and has no structural requirements.

The FreeSpan freestanding system is available both as a straight and transfer rail (H config) and in a variety of lengths.

FreeSpan straight rail is equipped with wheels facilitating correct positioning for both lifting and cleaning as well as being easier to relocate between lifting needs.

- Can be installed in a variety of care environments
- Offers adjustable height settings and easy clean materials
- The system is easy to assemble/disassemble without any tools



HCF071 FreeSpan™ Gantry Lift System

**Baxter**



## FreeSpan™ UltraTwin Lift System

The need for lifts for bariatric patients has increased considerably in the last few years. With a lifting capacity of 500 kg (1,014 lb), the UltraTwin system meets very high demands.

A freestanding system, and since it is not affixed to the walls or the ceiling, there are no special strength requirements for those structures. The system is available in a range of different rail lengths for optimal adaptation to the size of the room.

Thanks to a system with two lift motors that work together, UltraTwin not only lifts and transfers, it also helps position the patient in sitting, semi-reclining or horizontal positions. Available with two different widths between rails: one for sitting transfers and one for transferring in horizontal position with a stretcher.

HCF072 FreeSpan™ UltraTwin Lift System

## Likorall™ Overhead Lift Systems

The system is an ideal choice for those who want to move the lift motor along the rail electronically with a transfer motor, or to control the rail's electrical switches via a wireless hand control option. Includes a patented safety drum with speed limiter.

Safety features include a patented safety drum with speed limiter and electrical and manual emergency lowering. The motor's 200 cm (79") lifting interval handles lifting from the floor in most environments, and the motor can be equipped with a special carriage for easy room-to-room transfers.

HCF073 Likorall™ Overhead Lift Systems



## Stalham Tilting Shower Commode

The next-generation of multifunctional showering commodes. Made of strong, rigid materials with no weld joints for micro-fracture weak points ensuring its strength. The chair is also fitted with five swivelling castors four of which are braked.

### Structure

- Utilises a completely synthetic frame making it durable and lightweight. Coated tube frame design allows for a very high resistance to wear.
- Strong, rigid materials also have the added benefit of shock dissipation.
- Available with electric or hydraulic lift mechanism.
- Chair frame extends to recline seat and backrest.
- Also includes a device with bucket.

### Comfort

- Comfortable, adjustable head rest which combined with the tilting function allows for endless positions with this versatile chair.
- Sturdy, contoured back, head and leg supports have been ergonomically designed for optimum patient comfort.
- Footrests are height adjustable and swing away when not required.
- Moulded synthetic rubber over-seat which securely encloses the aperture and is kind to patient skin.

### Ease Of Handling

- Easy to use level mechanism allows fine adjustment of the chair back rest angle.
- A push handle is integrated for easy and accurate portering.
- Headrest tilt and height are adjusted with simple to use clip mechanisms.
- Fitted with four Ø 125mm braked castors.
- Arm rests which are easily retractable to enable secure transfer and patient access.
- Rubber over-seat has no seams and will not rip/ tear.

### Easy Cleaning

- Chair can be dismantled within 20 seconds without tools to allow for thorough cleaning.
- Designed without welding to avoid rust or micro-fracture weak points. Seamless joints ensure dirt or bodily fluids cannot be trapped.
- Capable of withstanding the most rigorous cleaning regime. Suitable for cleaning with NHS approved cleaning solutions and Clinell wipes (or other alcohol based wipes).

### Specifications

- Max User Weight: 150 kg
- Width: 65 cm
- Depth: 111 cm
- Seat Height: 58 - 57 cm
- Seat Depth: 43 cm
- Seat Width: 54 cm
- Weight: 29.3 kg



**STALHAM**

By Medi-Plinth



Made in the UK



Free Delivery

B

Nursing Homes

## Stalham 20 Mobile Commode

The ideal hygiene solution for care environments. These commodes are designed for ease of cleaning and user comfort.

### Structure

- Utilises a completely synthetic frame making it durable and lightweight. Coated tube frame design allows for a very high resistance to wear
- Strong, rigid material have added benefit of shock dissipation
- Includes a moulded removable potty as standard

### Comfort

- Moulded backrest is ergonomically designed for comfort
- Available as fixed or adjustable height versions
- Height adjustable footrests swing away when not required
- Moulded synthetic rubber over-seat which securely encloses the aperture and is kind to patient skin

### Ease Of Handling

- Push handle integrated in frame for easy, accurate portering
- Fitted with four Ø 125mm braked castors
- Armrests are easily retractable for secure transfer and access
- Rubber over-seat has no seams and will not rip/ tear

### Easy Cleaning

- Chair can be dismantled within 20 seconds without tools to allow for thorough cleaning
- Designed without welding to avoid rust or micro-fracture weak points. Seamless joints ensure dirt or bodily fluids cannot be trapped
- Capable of withstanding the most rigorous cleaning regime. Suitable for cleaning with NHS approved cleaning solutions and Clinell wipes (or other alcohol based wipes)

### Specifications

- Overall dimensions: 102 x 57 x 60 cm
- Seat dimensions: 47 x 40 cm
- Safe working load: 130 kg
- Product weight: 15 kg

**STALHAM**

By Medi-Plinth



Made in the UK



Free Delivery



**HDA348** Stalham 20 Mobile Commode - Fixed Height

**HDA348.1** Stalham 20 Mobile Commode - Adjustable Height

**HDA349** Stalham 20 Mobile Commode - Wide Version

## Stalham 64 Bariatric Mobile Commode

A fixed-height commode designed for bariatric care use.

### Structure

- Utilises a completely synthetic frame making it durable and lightweight. Coated tube frame design allows for a very high resistance to wear
- Strong, rigid material have added benefit of shock dissipation
- Heavy-duty backrest with aluminium construction
- Includes a moulded removable potty as standard

### Comfort

- Moulded backrest is ergonomically designed for comfort
- Wider seat is designed to accommodate larger patients
- Height adjustable footrests swing away when not required
- Moulded synthetic rubber over-seat which securely encloses the aperture and is kind to patient skin

### Ease Of Handling

- Arched rear frame section acts as ergonomic push handle
- Fitted with four Ø 125mm braked castors
- Armrests are easily retractable for secure transfer and access
- Rubber over-seat has no seams and will not rip/tear

### Easy Cleaning

- Chair can be dismantled within 20 seconds without tools to allow for thorough cleaning
- Designed without welding to avoid rust or micro-fracture weak points. Seamless joints ensure dirt or bodily fluids cannot be trapped
- Capable of withstanding the most rigorous cleaning regime. Suitable for cleaning with NHS approved cleaning solutions and Clinell wipes (or other alcohol based wipes)

### Specifications

- Dimensions: 74 x 90 cm
- Seat Dimensions: 56 x 48 x 64 cm
- Maximum user weight: 200 kg
- Weight: 22 kg

**STALHAM**

By Medi-Plinth



Made in the UK



Free Delivery



**HDA350** Stalham 64 Bariatric Mobile Commode - Fixed Height

## Stalham Compact Portering Chair

Compact portering chair with space saving design. Comfortable for patients and easy to manoeuvre with built-in features.

### Structure

- Utilises a completely synthetic frame making it durable and lightweight. Coated tube frame design allows for a very high resistance to wear
- Strong, rigid material have added benefit of shock dissipation
- Compact design for space-saving benefits
- Includes a moulded removable potty as standard

### Comfort

- Moulded backrest is ergonomically designed for comfort
- Height adjustable footrests swing away when not required
- Seat pad is contoured for patient comfort and features a rear drainage channel for water run-off

### Ease Of Handling

- Push handle integrated in frame for easy, accurate portering
- Fitted with four Ø 125mm braked castors
- Armrests are easily retractable for secure transfer and access
- Rubber over-seat has no seams and will not rip/ tear

### Easy Cleaning

- Chair can be dismantled within 20 seconds without tools to allow for thorough cleaning
- Designed without welding to avoid rust or micro-fracture weak points. Seamless joints ensure dirt or bodily fluids cannot be trapped
- Capable of withstanding the most rigorous cleaning regime. Suitable for cleaning with NHS approved cleaning solutions and Clinell wipes (or other alcohol based wipes)

### Specifications

- Overall dimensions: 102 x 57 x 60 cm
- Seat dimensions: 47 x 40 cm
- Safe working load: 130 kg
- Product weight: 15 kg

**STALHAM**  
By Medi-Plinth



Made in the UK



Free Delivery



**HDA686** Stalham Compact Portering Chair

## Stalham Braking Portering Chair

Compact portering chair with space saving design. Comfortable for patients and easy to manoeuvre with built-in features.

### Structure

- Utilises a completely synthetic frame making it durable and lightweight. Coated tube frame design allows for a very high resistance to wear
- Strong, rigid material have added benefit of shock dissipation
- Compact design for space-saving benefits
- Includes a moulded removable potty as standard

### Comfort

- Moulded backrest is ergonomically designed for comfort
- Height adjustable footrests swing away when not required
- Seat pad is contoured for patient comfort and features a rear drainage channel for water run-off

### Ease Of Handling

- Push handle integrated in frame for easy, accurate portering
- Fitted with four Ø 125mm braked castors
- Armrests are easily retractable for secure transfer and access
- Rubber over-seat has no seams and will not rip/ tear

### Easy Cleaning

- Chair can be dismantled within 20 seconds without tools to allow for thorough cleaning
- Designed without welding to avoid rust or micro-fracture weak points. Seamless joints ensure dirt or bodily fluids cannot be trapped
- Capable of withstanding the most rigorous cleaning regime. Suitable for cleaning with NHS approved cleaning solutions and Clinell wipes (or other alcohol based wipes)

### Specifications

- Overall dimensions: 102 x 64 x 76 cm
- Seat dimensions: 46 x 54 cm
- Safe working load: 130 kg
- Product weight: 15 kg

**STALHAM**  
By Medi-Plinth



Made in the UK



Free Delivery



**HDA685** Stalham Braking Portering Chair

## Stalham Stable Commode Chair

- Manufactured with plastic and aluminium
- Designed to fit over the toilet
- Adjustable height with seven positions
- Approved up to 130 kg body weight
- Available with or without backrest

### STABLE COMMODE CHAIR

- Seat height: 42 – 57 cm
- Seat size: 40 x 46 cm
- Max required space: 51 x 59 cm
- Weight w/o accessories: ~5 kg
- Max. user weight: 130 kg

### STABLE TOILET FRAME & SEAT

- Max required space: 51 cm x 59 cm
- Weight w/o accessories: ~5 kg

**HDA683** Stalham Stable Commode Chair

**HDA683.1** Stalham Stable Commode Chair with Bucket

**HDA683.2** Stalham Stable Commode Stool with Arms



**STALHAM**

By Medi-Plinth



Made in the UK



Free Delivery

## Stalham Stable Shower Chair

- Manufactured with plastic and aluminium.
- Designed for patient showering
- Adjustable height with seven positions
- Approved up to 130 kg body weight
- Available with or without backrest

### STABLE COMMODE CHAIR

- Seat height: 42 – 57 cm
- Seat size: 40 x 40 cm
- Max required space: 51 x 53 cm
- Weight w/o accessories: ~5 kg
- Max. user weight: 130 kg

### STABLE TOILET FRAME & SEAT

- Max required space: 45 cm x 53 cm
- Weight w/o accessories: ~4 kg

**HDA684** Stalham Stable Shower Chair

**HDA684.1** Stalham Stable Shower Stool with Arms

**HDA684.2** Stalham Stable Shower Stool



**STALHAM**

By Medi-Plinth



Made in the UK



Free Delivery

## Clinell Commode

The UK's number one infection prevention commode. Award-winning design. Quickly and easily dismantled for easy cleaning.

- Safe to use with chlorine, peracetic acid, hydrogen peroxide quaternary ammonium compounds
- Anyone can dismantle and reassemble quickly and easily.
- The commode is cost effective as one of the lowest priced, best value commodes on the market.
- Each commode comes with a five-year warranty on the stainless-steel frame and 12-month warranty on parts as well as the least expensive spare parts on the market.
- Designed to be adaptable to fit both pulp & plastic bedpans
- Can used as a shower chair or over a toilet.



**STR464** Clinell Commode

## Premium Dignity Portable Commode

A portable self-contained bidet commode toilet that will wash and dry the user without having to rely on a carer or family member. This allows the user to remain independent and enables them to toilet with dignity.

The commode is simple to operate using the detachable electronic control panel and can be used within minutes of it being delivered.

- No installation required & frame is height adjustable
- Reduces the need for a carer, promotes independence and restores dignity
- A portable commode which can be locked in place for ensured stability
- Wall mountable remote control with large clear buttons
- Controllable heated seat and water
- Adjustable water pressure and spray arm, giving a comfortable bidet wash every time
- Small light under seat for use at night
- **Water reservoir:** 3.5 litres of water (2-3 uses)
- **Dimensions:** 550 x 610 x 640-690 mm
- **Max user weight:** 160kg
- **Product weight:** 19kg



**HDA235** Premium Dignity Portable Bidet Commode

## Big John Bariatric Commode

Combines the comfortable Big John toilet seat with a height adjustable frame to provide support to larger, heavy users. It offers additional stability, with two arms to support the user and legs which have four ferrules sitting flat on the floor to provide a steady base.

The lowest seat height is just 18.5 inch (47cm) to a maximum of 22.5 inch (57cm). Use as an over-toilet frame or as a freestanding commode with the included Burton Commode Pan, with a two handle design.

- Flatpack design and easily packs again for travel or storage.
- 2-in-1 design, use as commode or over-toilet.
- Gives a 380kg weight limit to any toilet.
- Provides two arms for comfort and to make rising easier
- **Dimensions:** 620-660 x 670 x 680-775mm
- **Seat height:** 440-575mm (17.3 - 22.6 inch)
- **Maximum weight capacity:** 380kg
- **Product weight:** 7.8 kg



**HDA225** Big John Large Bariatric Commode with Pan & Lid

## Walton Height Adjustable Commode

For the first time, there is now a furniture commode which has height adjustable legs, so you can set it to the ideal height for you. It also features an arm rest on each side, to give you support when rising from the chair.

The premium aluminium and plastic construction is hygienic and extremely easy to clean, with a choice of two new weave designs to blend in perfectly with your other household furniture.

- Modern style with choice of designs
- Height adjustable for comfort
- Easy-to-clean plastic and aluminium
- Basket-weave styled chair with discreet commode pan
- **Available in your preferred colour choice:** white or brown
- **Seat height:** Min 16 inch (40.5cm) to Max 21 inch (53.5cm)
- **Maximum weight capacity:** 190kg



**HDA230** Walton Commode - White

**HDA230.1** Walton Commode - Brown

## Stalham Bathe 20 Hydraulic Shower Trolleys

Shower-proof patient trolleys with hydraulic lift mechanism.

### Structure

- Powder-coated stainless steel chassis and sub-frames
- There are a selection of different sizes available, to ensure a suitable size for most care environments
- Lift system supports weights of up to 200 kg

### Comfort

- Removable padded mattress included for patient comfort
- Fasteners/straps are available as accessories, for attachment on mattresses to siderails
- Trolley drains at both ends allowing the user person to be positioned in either direction
- Tilt-able in to Trendelenburg position at either end

### Ease Of Handling

- The stretcher has rubber bumper wheels on all four corners to protect walls and doorways
- Floor clearance at 160 mm to enable floor lift transfers
- Foldable side rails for efficient and safe patient transfer and transport – The side rails can be pressed together when travelling through narrow doorways
- Dual drainage offers easy change of designated head end

### Controls

- Foot operated hydraulic pedals allow for accurate control of height adjustment
- Hydraulic model lowers smoothly when pedal is pressed and stops immediately when pedal is released
- Manual tilt adjustment can be accessed from both sides

### Specifications

- Standard: 160 x 66cm
- Short: 190 x 66cm
- Long: 210 x 66cm
- Wide: 195 x 70cm
- Adjustable height: 60–90cm

**STALHAM**

By Medi-Plinth



Made in the UK



Free Delivery



**HCF209** Bathe 20 Standard Shower Trolley

**HCF209.1** Bathe 20S Pediatric Shower Trolley

**HCF209.2** Bathe 20L Extra Long Shower Trolley

**HCF209.3** Bathe 20W Extra Wide Shower Trolley

## Stalham Bathe 30 Electric Shower Trolleys

Shower-proof patient trolleys with electric lift mechanism.

### Structure

- Powder-coated stainless steel chassis and sub-frames
- There are a selection of different sizes available, to ensure a suitable size for most care environments
- Lift system supports weights of up to 200 kg

### Comfort

- Removable padded mattress included for patient comfort
- Fasteners/straps are available as accessories, for attachment on mattresses to siderails
- Trolley drains at both ends allowing the user person to be positioned in either direction
- Tilt-able in to Trendelenburg position at either end

### Ease Of Handling

- Electric lift model includes an on-board battery solution as standard – Also available with a removable battery option
- The stretcher has rubber bumper wheels on all four corners to protect walls and doorways
- Floor clearance at 160 mm to enable floor lift transfers
- Foldable side rails for efficient and safe patient transfer and transport – The side rails can be pressed together when travelling through narrow doorways
- Dual drainage offers easy change of designated head end

### Controls

- Foot operated electric controls allow for accurate control of height adjustment
- Electric model includes an audible tone when battery is running low –Also features an emergency stop button
- Manual tilt adjustment can be accessed from both sides

### Specifications

- Standard: 160 x 66cm
- Short: 190 x 66cm
- Long: 210 x 66cm
- Wide: 195 x 70cm
- Adjustable height: 60–90cm

**STALHAM**

By Medi-Plinth



Made in the UK



Free Delivery



**HCF210** Bathe 30 Standard Shower Trolley

**HCF210.1** Bathe 30S Pediatric Shower Trolley

**HCF210.2** Bathe 30L Extra Long Shower Trolley

**HCF210.3** Bathe 30R Shower Trolley (Removable Battery)

**HCF210.4** Bathe 30RS Pediatric Shower Trolley (Removable Battery)

**HCF210.5** Bathe 30RL Extra Long Shower Trolley (Removable Battery)



## Stalham Bathe 40 Electric Bariatric Shower Trolleys

Shower-proof bariatric trolleys with electric lift mechanism.

### Structure

- Powder-coated stainless steel chassis and sub-frames
- Designed with strong, high-quality materials to ensure suitability for lifting plus-size patients
- Durable mattress, made from a flame retardant PVC material
- Lift system supports weights of up to 450 kg

### Comfort

- Removable padded mattress included for patient comfort
- Fasteners/straps are available as accessories, for attachment on mattresses to siderails
- Trolley drains at both ends allowing the user person to be positioned in either direction
- Head rail folds to horizontal position for extra length
- Tilt-able in to Trendelenburg position at either end

### Ease Of Handling

- Bumper wheels on each corners to protect walls & doorways
- Large castors (150 mm) for convenient and easy transport
- Foldable 180° side rails in stainless steel that lock into position – The side rails can also be pressed together for entering narrow doorways
- Includes a 1m flexible drainage hose.
- On board, high-capacity, rechargeable batteries charged via main supply with magnetic battery charger connection

### Controls

- The hand-held control operates the power tilt in both directions and raises and lowers the trolley
- Convenient single foot control for brakes on all four castors
- Manual tilt adjustment can be accessed from both sides

### Specifications

- Size: 221 x 91.5 cm
- Height: 53-83 cm
- Safe working load: 450 kg

**STALHAM**  
By Medi-Plinth



**HCF211** Bathe 40 Bariatric Shower Trolley

**HCF211.1** Bathe 40R Bariatric Shower Trolley (Removable Battery)

## Stalham Bathe 96 Mobile Bath Lift System

Mobile bath lifts can operate as a chair, stretcher, or both.

### Structure

- Designed to be used with most supine baths. Chassis is both narrow and low, allowing for easy access to bath tub
- Powder coated, zinc-plated steel and stainless steel frame
- Seating/stretcher surfaces made of a soft, durable material
- Lift system supports weights of up to 150 kg

### Comfort

- Ergonomically designed hand grips help patient to feel secure
- Easy access and comfortable padded seating surfaces ensure a pleasant bathing experience.
- Comfortable back rest that can easily be moved to either arms for back support.

### Ease Of Handling

- Ø 100 mm castors, two with brakes, two with straight steering
- Removable side parts provide a simple, quick configuration change from chair to stretcher
- Arm supports can be folded away for easy access
- The leg configuration is designed for easy approach
- Commode seat on chair can be converted to smooth seat
- Audible low battery tone

### Controls

- Safety arm supports are included in both configurations
- A safety stop engages automatically if the chair or stretcher is lowered onto any surfaces or obstacles.
- Magnetic battery charger connection designed to prevent damage when charging.

### Specifications

- Adjustable height: 20 - 96 cm
- Max. overall height: 173 cm
- Max. frame width: 88cm
- Protection class: IP X4

**STALHAM**  
By Medi-Plinth



**HCF212** Bathe 96C Chair Only

**HCF212.1** Bathe 96CS Chair & Stretcher Combination

**HCF212.2** Bathe 96S Accessory stretcher add-on

## Stalham Bathe 17 Paediatric Hi/Low

Electric height-adjustable paediatric bath tub

### Structure

- Manufactured from fibreglass reinforced polyester – Frame and skirts are made of powder coated steel
- Attractive design, colour options for feet and skirts
- Space-saving design is suitable for environments with limited space, without sacrificing function, efficiency or comfort
- Lift system supports weights of up to 150 kg

### Comfort

- Removable padded mattress included for patient comfort
- Dual-synchronised lifting columns allow for quick and quiet height adjustment
- Factory-fitted thermostatic mixer regulates both the bathtub filling and the shower water temperature.

### Ease Of Handling

- Overflow control and pop-up drainage with hose – 40mm drainage can be attached to the floor or wall
- Pop-up drainage closes/opens by turning the overflow valve
- Adjustable feet for stability even on uneven floors
- Shower handle has a soft rubber outlet nozzle which is easy to clean and that gives comfortable soft water dispersion
- Clearance below the tub allows for hoist access and cleaning

### Controls

- Height adjustment is operated via a simple hand controller, with convenient placement hole
- Both hand controls and manual tilt can be operated from either side of the bathtub as required

### Specifications

- Size: 168 x 70cm
- Height: 66-96 cm
- Lift speed (empty): 16 mm/s
- Safe working load: 150 kg
- Weight (empty): 230 kg



HCF213 Bathe 17 Paediatric Hi/Low Bath

**STALHAM**

By Medi-Plinth



Made in the UK



Free Delivery

## Bathe CL Height Adjustable Bath Tub

Electric height-adjustable adult bath tub

### Structure

- The tub, side covers and maintenance hatch are made of fibreglass reinforced polyester covering the supporting frame, actuators, control unit and all internal sanitary installations
- Half inch cold/hot water inlet hoses located in the back
- Two legs including adjustable feet for uneven clothes
- Lift system supports weights of up to 150 kg

### Comfort

- The three-step adjustable foot support is pushed into the slots to accommodate the different lengths of patients and to avoid them from sliding down the bath
- The thermostat mixer is designed to regulate the water temperature to the bathtub

### Ease Of Handling

- Two built-in handles offer additional support when getting in and out of the tub
- Two synchronised actuators with double controls for height adjustment to infinite positions
- Maintenance hatch located at the rear can be removed for repair and maintenance work
- The shower handle with shower hose is to be used to shower the patient and to rinse equipment after cleaning
- The hand control is attached via spiral cord on the hatch bracket and is easy to use

### Safety

- Overflow protection and pop-up drain which opens and closes the drainage system by rotating the overflow valve
- Auto-fill function available as optional accessory

### Specifications

- Size: 168 x 70cm
- Height: 66-96 cm
- Lift speed (empty): 16 mm/s
- Safe working load: 150 kg
- Weight (empty): 230 kg



HCF214 Bathe CL Height Adjustable Bath Tub

**STALHAM**

By Medi-Plinth



Made in the UK



Free Delivery

HCF214.1 Bathe CL air spa system with no.12 air nozzles

HCF214.2 Bathe CL LED colour changing system

HCF214.3 Bathe CL Soundwave system, Aux & Bluetooth

HCF214.4 Bathe CL Custom colour bath side

## Bradshaw Low Nursing Care Bed

- Quiet and reliable electric actuators providing unobtrusive operation and liability
- Electrically operated variable height for ease of patient access and to assist the work of the carer, by reducing patient lifting and handling
- Sturdy, fully tested construction capable of taking a maximum user weight of up to 180kg (28 stone)
- Simple handset control for all electrically operated functions and movements
- Electrically operated rising backrest and kneebreak, for comfort and ease of use
- Infinitely variable forward and reverse tilt positioning to suit the needs of differing medical conditions
- Four locking swivel castors, for easy manoeuvre and safety
- Bed can be dismantled and stored on a transportation system for ease of movement and storage
- Adjustable self locking side rails, providing additional safety, can be lowered at both the head and foot ends
- **3 year warranty:** 1st year parts & labour, 2/3 years parts only
- **Height range:** 19–59cm
- **Width:** 105.5cm
- **Length:** 225cm
- **Bed height at highest point:** 118cm
- Light Oak is the standard finish but you may choose from 4 others – **Please state selection when ordering**



**Beech**   **Elm**   **Light Oak**   **Maple**   **Walnut**



**Purple**   **Cream**   **Green**   **Brown**   **Taupe**

- HCF775.1** Low Nursing Care Bed
- HCF776** Low Nursing Care Bed with Padded Head End
- HDA088** Softrest Mattress (medium risk)
- HDA089** Softrest Contour Mattress (medium/high risk)
- HDA587** Permaflex Underlay Mattress



## Bradshaw Nursing Care Bed

- Electrically operated variable height for ease of patient access and to assist the work of the carer, by reducing patient lifting and handling
- Adjustable self locking side rails, providing additional safety, can be released at both the head and foot ends
- Bed can be dismantled and stored on a transportation system for ease of movement and storage
- Four locking swivel castors, for easy manoeuvre and safety
- Infinitely variable tilt and reverse tilt positioning to suit the needs of differing medical conditions
- Rising backrest and kneebreak, electrically operated
- Simple, handset control of all electrically operated functions
- Sturdy, fully tested construction capable of taking a maximum user weight of up to 180kg (28 stone)
- Quiet and reliable electric actuators providing unobtrusive operation and reliability
- **3 year warranty:** 1st year parts & labour, 2/3 years parts only
- **Height range:** 39cm to 79cm
- **Width:** 105.5cm (including siderails)
- **Length:** 225cm
- **Overall bed height at highest point:** 135cm
- Light Oak is the standard finish but you may choose from 4 others – **Please state selection when ordering**



**Beech**   **Elm**   **Light Oak**   **Maple**   **Walnut**



**Purple**   **Cream**   **Green**   **Brown**   **Taupe**

- HDA062** Care Bed – Fully profiling with Metal Slats
- HDA063** Care Bed with Padded Head End
- HDA088** Softrest Mattress (medium risk)
- HDA089** Softrest Contour Mattress (medium/high risk)
- HDA587** Permaflex Underlay Mattress

## Boston Home Care Bed

The Boston Home Care Bed is available in two different combinations for maximum flexibility and safety. Choose between either a bed with four plastic feet or with castors.

- All round extending legs
- **Maximum user weight:** up to 180kgs (28 stone)
- **Under bed clearance without castors:** 23.5cm
- **Under bed clearance with castors:** 36cm
- **Width:** 100cm / **Length:** 214.5cm / **Height:** 46cm

**HDA401** Bed with four plastic feet

**HDA402** Bed with 2 brake & 2 swivel castors



## Solite Pro Beds

Acknowledged to be the highest specification product in its class, the Solite range of beds have been designed for client comfort, versatility, functionality and performance.

In recent years, enhanced by the use of laser technology in design and manufacture for total dimensional consistency, the Solite has become the market leader in terms of performance and functionality combined with simple, repeatable assembly and disassembly.

Introducing the all-new Solite Pro range of profiling beds with electric backrest and knee break function and variable height control, now featuring an option for integral full length side rails.

- Redesigned aesthetics retaining attractive domestic feel
- Sections strengthened for performance and reliability
- Optional integral full length side rails for safety and usability
- Improved integral leg extension with safety features to prevent entrapment
- Improved corner locking mechanism for ease of assembly
- Improved auto regressing backrest prevents sacral pinching
- Infinitely variable foot down tilt (head down tilt available for nursing care environment as an optional extra handset)
- Four braked castors for manoeuvrability and safety
- Easy-use handset controls all functions, with lock out feature
- Supplied complete with transport stand
- **Maximum user weight:** 190kg (30 stone)
- **Maximum safe working load:** 222kg (35 stone)

## Solite Pro Community Bed

Designed and independently certified as a fully compliant bed within the remit of the general medical bed standard IEC 60601-2-52:2009 and IEC 60601-1-11:2010 governing medical electrical equipment specific to home care requirements

- **Height range:** 39.5–81.5cm
- **Width:** 106cm overall
- **Length:** 225cm (239.5cm when fully extended)
- **Bed weight:** 87.5kg



**HDA562** Solite Pro Community Bed

## Solite Pro Low Community Bed

Descending to a mattress platform height of just 29.5cm, the Solite Pro Low provides the ideal solution where preventing opportunities for patient falls is a very important consideration.

- **Height range:** 29.5–71.5cm
- **Width:** 106cm overall
- **Length:** 225cm (239.5cm when fully extended)
- **Bed weight:** 87.5kg



**HCF775.1** Low Nursing Care Bed

## Acclaim VE Mattress

- Turning Support Mattress (2 way, head to foot)
- High Risk Mattress
- Ergonomically designed castellated visco elastic top layer for optimum pressure relief and benefits from a zoned surface
- Engineered to work specifically with profiling beds
- “Waterfall Flap” design and “user friendly” zip
- Top part of cover is a two-way stretch, waterproof/vapour-permeable material with white underside, premium stitched seams and covered zip (welded cover version also available)
- Base of cover is a heavy duty nylon material
- The ‘U’ foam construction of the side walls has been engineered to provide added stability and strength
- **Maximum user weight:** 254kg / 40st
- **Product weight:** 15kg
- **Dimensions:** 15.2 x 88 x 199cm



**HDA083** Acclaim VE Mattress

## Softrest Mattresses

Specifically designed for nursing and residential care environments. This range provides affordable bed surfaces to improve overall comfort and protection for patients. All mattresses include a **5 year warranty**.



### Softrest Mattress

A turning, medium risk support mattress. The stitched cover is made from a two-way stretch vapour-permeable PU coated fabric and includes a covered zip

- **Maximum user weight:** 190kg (30st)
- **Dimensions:** 15.2 x 88 x 199cm
- **Product weight:** 12kg



**HDA088** Softrest Mattress (medium risk)

### Softrest Contour Mattress

A turning, medium to high risk support, profiling mattress. The stitched cover is made from a two-way stretch vapour-permeable PU coated fabric and includes a covered zip

- **Maximum user weight:** 190kg (30st)
- **Dimensions:** 15.2 x 88 x 199cm
- **Product weight:** 14kg



**HDA089** Softrest Contour Mattress (medium/high risk)

### Softrest VE Mattress

Turning Support Mattress 2 way – head to foot. The stitched cover is made from a two-way stretch vapour-permeable PU coated fabric and includes a covered zip

- **Maximum user weight:** 190kg (30st)
- **Dimensions:** 15.2 x 88 x 199cm
- **Product weight:** 12kg



**HDA150** Softrest VE Mattress

### Permafex Underlay Mattress

The Permafex Underlay is developed to support dynamic overlay mattress systems. The underlay is placed under the dynamic overlay and not used on its own as a support surface.

- **Dimensions:** 5 x 88 x 199cm



**HDA587** Permafex Underlay Mattress

### Softform Premier Active 2 Mattress

Clinically proven hybrid technology, delivers therapy at the touch of a button. The interface combined with active alternating air cells, provides prevention & treatment of severe pressure ulcers.

Offers a comfortable pressure redistributing surface for patients at 'Very High Risk'. Using power unit, the static surface is quickly and easily transformed into an effective therapeutic surface.

- Enhanced patient comfort with effective pressure relief
- High specification castellated foam surface
- Clinically proven for all categories of pressure ulcers
- Strikethrough resistant (SRT) cover
- Crib 5 or crib 7 fire retardant cover options

**Maximum User Weight:**

247.6kg (39 st)

**Warranty:**

8 year foam, 4 year cover, 2 year pump & air insert



**HDA508** Softform Premier Active 2 Mattress & pump (197 x 88cm)

### Softform Premier ActiveCARE Mattress

The clinically proven Softform Premier ActiveCARE mattress offers a 'Very High Risk' high specification static surface.

Should a patient require stepping up to a dynamic surface, a discreet pump can be fitted to the air insert, transforming the mattress into an alternating surface, delivering additional levels of pressure relief.

- The air insert within the mattress allows stepping up and down between static and dynamic alternating systems
- The outer cover is a multi stretch, waterproof, PU fabric with high frequency welded seams; and a full length zip cover.
- Cost saving modular build - each piece is easily replaced
- Plug and play robust pump with audible and audio alarm.

**Maximum User Weight:**

247.6kg (39 st)

**Warranty:**

2 year on all parts



**HDA508.2** Softform Premier ActiveCARE Mattress & pump (200 x 88cm)

## Acclaim Flow Hybrid Mattress

The Acclaim Flow is a non-powered mattress replacement system using Air Flow Technology, a clever combination of air cells and foam developed to achieve optimum pressure reduction. The system features automatically adjusting valves across 10 individual latitudinal air cells which respond to the patient's weight and movements without a powered pump.

This advanced technology ensures the mattress can be utilised for the most vulnerable patients, as each cell operates independently by regulating internal pressure and is not reliant on the air flow from cell to cell. This ensures optimum pressure reduction and the best support surface for your patient's needs.

- High performance non-powered hybrid system.
- Zoned, castellated foam overlay - individual heel, head and body zones facilitate appropriate localised pressure reduction.
- Firm edges for ease of patient ingress/egress and transfers  
Heavy duty anti slip base
- Vapour permeable and waterproof multi-way stretch cover
- Welded seams and waterfall flap
- Internal cells incorporated securely into foam
- Modular design to allow full part replacement
- **Patient Weight Limit:** 36st (230kg.)
- **5 years warranty:** Cover, foam and cells

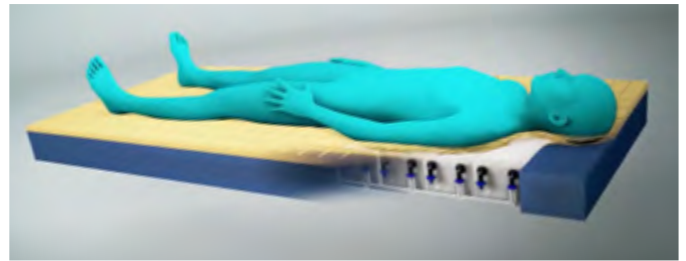

**HDA561** Acclaim Flow Hybrid Mattress System

## Clarus Bedside Cabinets

The new range of Clarus bedside cabinets and overbed tables from Sidhil brings together the latest innovative design and modern materials to deliver a solution which is practical, robust and cost effective, integrating as one unit to reduce trip hazards and create more space in the modern ward environment.

Clarus bedside cabinets and overbed tables are configurable to meet specific requirements.

- Drawers removable to aid cleaning, shelf design retains liquids
- Four castors, front castors with locks
- Built in towel support and drinking bottle storage at rear
- All edges and corners are rounded to aid cleaning
- Large bottom cabinet door which can be configured for right or left hand opening, opens to 175° for easy access
- Internal shelf which is fully removable for easy cleaning



**HCF1310** Bedside Cabinet - 3044 (Please specify colour when ordering)

**HCF1311** Bedside Cabinet - 3045 (Please specify colour when ordering)

**HCF1312** Bedside Cabinet - 3046 (Please specify colour when ordering)

**HCF1313** Bedside Cabinet - 3047 (Please specify colour when ordering)

Ivory Grey Sand Lemon Yellow Pumpkin Orange Red Blue Green

White Woodgrain Birch Light Oak Light Oak Black Woodgrain Grey Oak Wenge

**2 Year Warranty**

## Bedside Cabinets

The Shuttleworth bedside cabinets are designed to combine security, convenience and style. Providing an aesthetically pleasing way to store both personal items and medication safely and responsibly.

Designed to be lightweight, robust and compact, ensuring they are easy to manoeuvre. With additional features included as standard, such as fitted towel rails and lower storage areas.

The safety of a patients belongings and storage of medication for self-administration is important, which is why we have a range of locking options including master keys to meet your requirements.

- Designed with the NHS, to incorporate the provision of patients own secure, safe storage of valuables and self-administration drugs
- Manufactured with MDF core and beech melamine covered or powder coated in blue/white epoxy for ease of cleaning
- ABS high impact edging in matching finish
- Towel rail at rear fitted as standard
- Mounted on four swivel castors
- Lower hinged storage cabinet for personal belongings
- **Standard dimensions:** 470 x 530 x 980mm

**HDA589** Cabinet with CAM lock

**HDA590** Cabinet with Digital lock

**HDA591** Cabinet with Drawer & CAM lock

**HDA592** Cabinet with Drawer & Digital lock

**HDA593** Cabinet with Drawer, Digital lock & Plastic Top

**HDA594** Blue/White Cabinet with CAM lock

**HDA595** Blue/White Cabinet with Digital lock

**Shuttleworth**



Made in the UK Since 1953



**HDA590**



**HDA591**



**HDA595**



**HDA593**

B

Nursing Homes

**Shuttleworth**



Made in the UK Since 1953

**HDA597**



**HDA596**



## Bedside Cabinets with Wardrobe

Improving on the storage space offered with our standard Bedside Cabinets, we also provide cabinets with the addition of tall wardrobe space allowing patients to safely store clothing along with their belongings and medication.

These tall wardrobes are able to be fitted to any variation of bedside cabinets listed above, contact us for further details and pricing where required.

- Designed with the NHS, to incorporate the provision of patients own secure, safe storage of valuables and self-administration drugs
- Manufactured with MDF core and beech melamine covered for ease of cleaning
- ABS high impact edging in matching finish
- Towel rail at rear fitted as standard
- Mounted on four swivel castors
- Side-fitted wardrobe for storage of clothing
- Lower hinged storage cabinet for personal belongings
- **Standard dimensions:** 720 x 530 x 1366mm

**HDA596** Cabinet with CAM lock & Wardrobe

**HDA597** Cabinet with Drawer, CAM lock & Wardrobe

## Sunflower Hospital Bedside Furniture

Stylish and contemporary in design, strong and durable in construction our Axis Hospital Bedside Lockers provide the ideal solution for storing and securing medicines and personal belongings on the ward. Manufactured from robust MFC material and designed to BS1765-1:1990. Our Axis bedside lockers come with rounded vinyl wrapped matching tops and have been designed to be cost effective, strong, easy to clean and offers good infection control performance.

- Wrapped matching rounded vinyl tops for added safety
- 60mm castors (front 2 braked)
- "Bolted through" castors/door fixings for strength, hygiene and longevity
- Stylish satin finish easy clean handles
- Right or Left hand hinged cupboard doors (BSL3)
- 18/25mm MFC construction
- Three contemporary finishes, White/Oak/Beech
- BS EN 16121 : 2013 Level 2 Security, Strength, Durability & Stability
- FIRA Standard 6250 2005 Specification: Adhesion Performance, General/Severe
- Master Key Over-ride on DCL
- Lock Options:
  - Keyed Alike (KA) - Keyed to differ (KD)
  - Digital Combination Lock (DCL)
- Easy clean design and materials
- **NEW** 5 year warranty

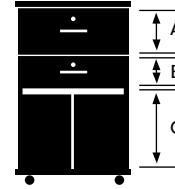

**Overall dimensions**  
99cm(H)  
45cm(W)  
49cm(D)

**Internal dimensions**  
A 20cm(H) B 12cm(H)  
C 46cm(H)

### Sun-BLS1/COLOUR/KA

Axis Bedside Locker, keyed alike, large locking top drawer, locking small middle drawer, saloon bottom doors

**SUN-BLS1-COLOUR-KA** Axis Bedside Locker - Keyed Alike

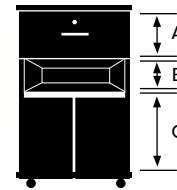

**Internal dimensions**  
A 23cm(H) B 13cm(H)  
C 46cm(H)

**Overall dimensions**  
99cm(H)  
45cm(W)  
49cm(D)

### Sun-BLS2/COLOUR/KA

Axis Bedside Locker, keyed alike, large locking fold down shelf, open access shelf, saloon bottom doors

**SUN-BLS2-COLOUR-KA** Axis Bedside Locker - Keyed Alike

### Lock Options please enquire



Keyed Alike Locks (KA)



Keyed to Differ Locks (KD)



Digital Combination Locks (DCL)

### Finishes please specify colour when ordering



White



Oak



Beech

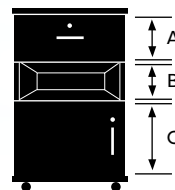

**Overall dimensions**  
99cm(H)  
45cm(W)  
49cm(D)

**Internal dimensions**  
A 20cm(H) B 17cm(H)  
C 41cm(H)

### Sun-BLS3/COLOUR/KA

Axis Bedside Locker, keyed alike, large locking top drawer, large open access shelf, right or left hand hinged locking bottom cupboard

**SUN-BLS3-COLOUR-KA** Axis Bedside Locker - Keyed Alike



## Sunflower Bedside Furniture

Stylish & contemporary in design, strong and durable in construction, our bedside combination units provide the ideal solution for storing and securing personal items. Available in three finishes, all of which are designed to be easy to clean.

- Available with or without locks (2 keys per lock)
- 18/25 MFC - Manufactured chip board construction
- Available in left or right hand
- Durable 2mm panel edging all round
- Chrome hanging rail in wardrobe
- 60mm castors (front 2 braked)
- Stylish flush fitting handles
- Easy clean design and materials
- Supplied fully assembled
- **NEW** 5 year warranty

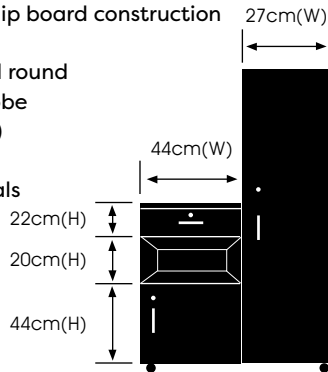

**Bedside Combination Unit (Mobile)**  
144cm(H) 71cm(W) 49cm(D)

**SUN-CBHBC4-MFC-LOCKS** Left Hand Bedside Combination Unit with Locks

**SUN-CBHBC5-MFC-LOCKS** Right Hand Bedside Combination Unit with Locks

**finishes** please specify when ordering



Beech



Oak

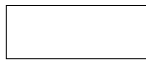

White



**sunflower**  
HEALTHCARE FURNITURE



B

Nursing Homes

## Height Adjustable Over Bed Tables

This modern design is durable and very easy to clean.

Adjustable height tables with a robust gas strut. Variations are available suitable for use with twin leg for under a bed and single U shaped leg to fit around a chair/wheelchair.

Each table is compliant with BS2483:1977 for Overbed Tables. The easy-clean tops can be selected from a white or beech finish as required with the option to include a lip or recess in the table to secure items.

- Fully height adjustable between 745-1100mm
- Single or Twin leg bases
- Powder coated white/grey base for ease of cleaning
- Available with a white or beech finished top surface
- Top surface manufactured with MDF core
- Mounted on swivel castors

**Dimensions:** 945 x 405 x 745-1100mm

**Shuttleworth**



Made in the  
UK Since 1953



HDA572



HDA578

**HDA572** Single Leg Table - Beech Top with Lip

**HDA573** Single Leg Table - White Flat Top

**HDA574** Single Leg Table - White Moulded Recessed Top

**HDA575** Single Leg Table - Beech Flat Top

**HDA576** Twin Leg Table - Beech Top with Lip

**HDA577** Twin Leg Table - White Flat Top

**HDA578** Twin Leg Table - White Moulded Recessed Top

**HDA579** Twin Leg Table - Beech Flat Top

## Sidhil Easi-Riser Overbed Table

The 'Easi-Riser' range of adjustable overbed tables are available with both standard and two-piece tilting tops and a choice of bases to suit different environments and patient requirements.

Supplied fully assembled with four swivel castors for ease of movement, these castors allow the bed tray table to be quickly positioned for meals, reading and other activities.

- Gas assisted variable height table for client comfort
- Anti-trapping safety feature
- Four swivel castors for ease of manoeuvrability
- Fire retardant, laminate top with anti-trapping safety feature and useful raised upstand.
- Magnolia epoxy coating with Biocote
- Raised upstand supplied fully assembled

### Dimensions

- Adjustable height: 74-109cm
- Width: 38cm
- Length: 91cm

Available in four finishes - Please state when ordering

<b>HDA078</b>	Standard Based Overbed Table
<b>HDA403</b>	Wheelchair Based Overbed Table
<b>HDA427</b>	Wheelchair Base Tilt Topped Overbed Table



## Sunflower Overbed/Overchair Tables with High Impact PVC Tops

Stylish & contemporary in design, strong and durable in construction, our overbed tables provide the ideal daily solution for multiple uses.

- C-Shape or Parallel Leg Base – for over bed or chair use
- Available with 1 Piece Top (SUN-OBT5C/P)
- Tilting Top raises from 0 -45°
- High Impact PVC Tops
- Quick and easy height adjustment between 76cm -109cm
- Anti-trapping safety feature – prevents trapping of patient between the bed and table
- Sealed tubular steel base – infection control friendly
- 4 high quality swivel castors – for ease of movement
- Durable and hygienic white epoxy coating base and frame
- Available in 2 finishes, Beech or White
- Supplied fully assembled – ready to use
- Safe working load: 25kg
- Weight: 20kg
- **NEW** 5 year warranty



**High Impact PVC** is a heavy duty material which can be formed into recesses, providing a sealed area which can retain liquids and other items. It is strong and durable, resistant to stains and heat. Its smooth finish and rounded edges make it easy to clean and is infection control friendly.

<b>SUN-OBT5P</b>	Overbed Table - Parallel Base with High Impact PVC Recessed Top
<b>SUN-OBT5C</b>	Overbed Table - C-Shape Base with High Impact PVC Recessed Top

**SUN-OBT5C**  
Overbed Table C-Shape Base with Flat Recessed Top  
**DIMENSIONS - See previous page**

**finishes** please specify when ordering

Beech	White

## Sunflower Overbed/Overchair Tables with MFC or Caomcompact Grade Laminate Top

Stylish & contemporary in design, strong and durable in construction, our overbed tables provide the ideal daily solution for multiple uses.

- C-Shape or Parallel Leg Base – for over bed or chair use
- Available with 1 Piece Flat Top (OB1C-P & OBT2C-P)
- Available with raised lip (OBT3C-P)
- Quality vinyl wrapped top (OBT1C-P)
- Compact Grade Laminate Top Construction (OBT2C-P -OBT3C-P)
- Quick and easy height adjustment between 76cm -109cm
- Anti-trapping safety feature – prevents trapping of patient between the bed and table
- Sealed tubular steel base – infection control friendly
- 4 high quality swivel castors – for ease of movement
- Durable and hygienic white epoxy coating base and frame
- Available in 2 finishes, Beech or White
- Supplied fully assembled – ready to use
- Safe working load: 25kg
- Weight: 20kg
- **NEW** 5 year warranty

**SUN-OBT1P** Overbed Table - Parallel Base with Vinyl Wrapped Flat Top

**SUN-OBT1C** Overbed Table - C-Shape Base with Vinyl Wrapped Flat Top

**Compact Grade Laminate** is a high-density fibreboard with a high strength melamine coating. It is extremely strong and durable, resistant to stains, moisture, heat and scratching. Its smooth finish and rounded edges make it exceptionally easy to clean.

**SUN-OBT2P** Overbed Table - Parallel Base with Compact Grade Laminate Flat Top

**SUN-OBT2C** Overbed Table - C-Shape Base with Compact Grade Laminate Flat Top

**SUN-OBT3P** Overbed Table - Parallel Base with Compact Grade Laminate Flat Top and Raised Lip

**SUN-OBT3C** Overbed Table - C-Shape Base with Compact Grade Laminate Flat Top and Raised Lip

### Overbed/Overchair Table

109cm(H) 95cm(W) 45cm(D)

Overbed Top 95cm(W) 45cm(D)

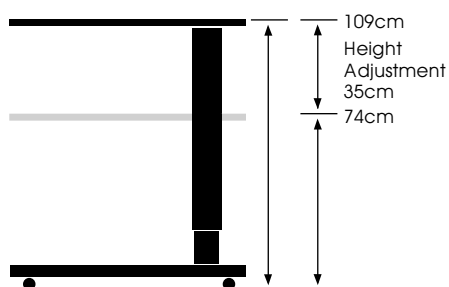

**finishes** please specify when ordering



Beech



White

**ASTRO**



**SUN-OBT1C**  
Overbed Table  
C-Shape Base with Vinyl Wrapped Flat Top



**SUN-OBT2C**  
Overbed Table  
C-Shape Base with Compact Grade Laminate Flat Top



**SUN-OBT3P**  
Overbed Table  
Parallel Base with Compact Grade Laminate Flat Top & Raised Lip



## Overbed Table

- Chrome plated & powder coated steel frame
- Angle adjustable table top to suit various end users
- Split-legged base that is adjustable in height
- Rails on table edges prevents items slipping off
- Laminated teak effect
- Easy to clean



**Height Adjustment:** 61-91cm  
**Table Size:** 61 x 40cm  
**Max Load:** 10kg

**HDA037** Overbed Table

## PATSLIDE® Patient Transfer

- PATSLIDE® has proven itself through daily use in hospitals around the world.
- Not only makes the job easier and safer, but also reduces the risk of injury to nursing staff when transferring patients.
- Eliminate the distress and discomfort patients can feel when being transferred.
- This unique product has reduced back strain during patient transfer – a factor which previously contributed to many lost working hours.
- Safe & Easy to use and clean
- Static Insulative & Radio-Lucent
- Lightweight, Resilient and Tolerant to impacts



**AE1202** All Purpose - 1525 x 635mm

**AE1203** Theatre - 1525 x 560mm

**AE1204** Slimline - 1400 x 480mm

**AE1205** Half Size - 750 x 635mm

## Able Assist Patient Transfer Aid

The Able Assist Patient Adjustable Transfer Aid provides a safe and easy solution for a carer wishing to transfer a client.

It enables users to participate in transfers, maintaining patient independence, and is also ideal for transferring them from room to room.

- It is very manoeuvrable and light to use
- Manufactured with a substantial aluminium robust frame
- Maximum user weight limit of 185Kg
- The Able Assist enables users to participate in transfers, maintaining patient independence
- Ideal for transferring Users from room to room
- The Able Assist is ideal for those users who can raise from a seated position to a standing position
- The user can have their legs supported by the knee brace and hold on to the horizontal bar in front of them
- The 4 wheels, 2 of which have brakes, enable this aid to be manoeuvred easily from room to room
- The narrow width of this aid enables the Carer to manoeuvre easily through standard doorways
- The Able Assist can be wheeled directly up to a toilet, with wheels positioned either side of the toilet offering the User more dignity to sit down

### Specification:

- Height: 106cm
- Width: 62cm
- Length: 82cm
- Seat Height: 62cm
- Seat Width: 58cm
- Seat Depth: 31cm
- User Weight Capacity: 185kg (29st)
- Product Weight: 31kg

**HDA567** Devilbiss Able Assist – Adjustable Leg

**HDA569** Transfer Sling for Devilbiss Able Assist



**HDA569**



## Sidhil Laundry Trolleys

- Easy to clean, powder coated tubular steel construction
- Easy to steer and manoeuvre, with braked castors for safety
- Variety of attractive colour options
- Nylon, mesh and waterproof bag options available
- When ordering, please specify your choice of lid for each trolley
- **Bag holders are also available**



- |               |   |
|---------------|---|
| <b>HNH141</b> | Sidhil Single Laundry Trolley                     |
| <b>HNH142</b> | Sidhil Double Laundry Trolley                     |
| <b>HNH143</b> | Sidhil Triple Laundry Trolley                     |
| <b>HNH144</b> | Sidhil Quad Laundry Trolley                       |
| <b>HNH149</b> | Sidhil Bag Holder – Required for each Laundry Bin |

## Sidhil Linen Trolleys

- Variety of attractive colour options
- Easy to steer and manoeuvre, with braked castors for safety
- Nylon, mesh and waterproof bag options available
- **Height:** 91.5cm
- **Diameter:** 48.5cm
- **Bag Size:** 46 x 76cm
- **Bag holders are also available**



- |               |   |
|---------------|---|
| <b>HNH128</b> | Linwood Single Linen Trolley – Frame only |
| <b>HNH129</b> | Linwood Double Linen Trolley – Frame only |
| <b>HNH130</b> | White Polyester Linen Bag                 |
| <b>HNH131</b> | Blue Polyester Linen Bag                  |
| <b>HNH132</b> | Red Polyester Linen Bag                   |
| <b>HNH133</b> | Green Polyester Linen Bag                 |

## Soiled/Clean Linen Trolleys

Our robust and practical range of linen trolleys offer a strong and versatile solution for all medical and care applications.

Each can hold one or two linen bags, utilising an open ring shaped loop or can be opened via foot pedal with a secure closing lid. Also available is a lockable linen trolley which is fully enclosed with two internal shelves.

- Single or double ring trolleys
- Designed specifically for the NHS and ideal for use in medical environments
- Trolleys help to organise bed linen
- Cabinet trolleys with optional fully enclosed doors
- Foot pedals with soft closing lids
- Options for mild steel or stainless steel construction
- Other sizes are available upon request



**HCF1561**

- |                |   |
|----------------|---|
| <b>HCF1554</b> | Single Ring Soiled Linen Trolley – Blue                 |
| <b>HCF1555</b> | Single Ring Soiled Linen Trolley – Stainless Steel      |
| <b>HCF1556</b> | Single Soiled Linen Trolley – Soft Close Pedal Operated |
| <b>HCF1557</b> | Double Ring Soiled Linen Trolley – Blue                 |
| <b>HCF1558</b> | Double Ring Soiled Linen Trolley – Stainless Steel      |
| <b>HCF1559</b> | Double Soiled Linen Trolley – Soft Close Pedal Operated |

## Shuttleworth

Made in the UK Since 1953



**HCF1555**



**HCF1558**



**HCF1553**



**HCF1559**

- |                |   |
|----------------|---|
| <b>HCF1553</b> | Bed Changing Trolley                      |
| <b>HCF1560</b> | Clean Linen Trolley with Shelves          |
| <b>HCF1561</b> | Enclosed Clean Linen Trolley with Shelves |

## Pachymetry PachPen

The perfect combination of accuracy, portability and comfort. The superior ergonomic design fits comfortably in any hand, which is a major improvement from other handheld models.

- 65 MHz sampling probe ensures precise measurements
- IOP correction calculation converts IOP measurements quickly
- Superior ergonomic design fits comfortably in any hand
- Versatility helps to save time and ease you practice demands
- Gentle touch 2.5 mm diameter probe tip ensures comfort
- Long-lasting lithium battery will last approx. 15,000 readings



HL0158 Accutome PachPen £2,335.00

## Pulsair intelliPuff Tonometer

The Keeler intelligent puff system giving you a quantum leap forwards in accuracy and ease of use. intelliPuff embodies electronic and optical technology to deliver you the speed, accuracy and ease of use you and your patients deserve.

Gentle is understating the new system - if the patient has high pressures the puff will automatically increase for the next measurement. Kind, intelligent and simple. Technology working for you.

Save valuable space, use less than 50% of the space of conventional non contact tonometers and is the only model that can be wall mounted.



HL0157 Pulsair intelliPuff Non Contact Tonometer £2,965.01

## DGH55B Pachmate2

The ultimate in portable pachymetry, only 6.9 inches long and 3.6 ounces in weight. A handheld pachymeter that gives accurate reliable corneal thickness measurements.

- Accuracy and reproducibility
- Personalised configuration memory
- Durable portability
- Detachable and rotatable probe
- Bluetooth® information transfer



HL0056 DGH55B Pachmate2 Pachymeter

## DGH Scanmate B Scan

Combines the most advanced ultrasound technology available with the processing power, data storage and connectivity advantages of a personal computer. The DGH 8000 is equipped with dual 12.5 MHz and 15 MHz frequencies in the same probe, which results in a unique depth selection range from 3 cm and 6 cm in 12.5 MHz mode and 5 cm and 10 cm in 15 MHz mode.

- Connects to a PC via USB2
- Portable and easy to use
- CD Software included
- Video and still images
- Transducer frequency: 12Mhz & 15Mhz



HL0767 DGH Scanmate B Scan

## Volk Pictor Imaging Device

Volk Pictor is a truly portable digital imaging device that provides a variety of imaging capabilities with interchangeable modules.

This versatile hand held device is available with the option of four key imaging modules for examination: ophthalmic-posterior, ophthalmic-anterior segment, otoscopic and dermatoscopic

- 4x Modules to meet your requirements
- Image resolution of up to 2560 x 1920 pixels
- Image targeting and capture using infrared or white light
- LED illumination
- Digital Zoom



HOP1077 Pictor with all modules

## SK Med Hand Held Slit Lamp

Hand-held slit lamp, bio-microscope – small, portable solution ideal for ophthalmology, optometry and veterinary practices.

- High definition optical performance for accurate diagnosis
- 10x / 16 x zoom magnification
- +/- 60 slit angle
- High luminance: white LED
- Smooth Illumination System
- Diopter Compensation -7D +7D
- Wireless Working Mode via AA Battery (Not Included)
- Filter Red Free, Cobalt Blue, Heat Absorption
- Filter Rotation
- Easy on/off switch
- Application in a wide range of situations
- 2 hours of continuous operation



HLO793 SK Med Hand Held Slit Lamp

### Keeler Retinoscope set

- Glass lenses from UK provide greater clarity than ever before.
- Pupillometer for easier pupil size estimations.
- Morton Lens Track control allows you to select lens powers from +44D to -45D
- Allows rapid confirmation of neutralisation by changing the beam from divergent to convergent.
- Retinoscope has two aperture choices: 4mm to optimise brightness, 1.7mm to optimise resolution
- **Includes:** Specialist ophthalmoscope, Professional retinoscope, 2x Handles, 2x Lithium Ion Batteries, Spare bulbs, Protective case and Instructional CD



HOP740 Specialist Ophthalmoscope and Retinoscope Set

### Keeler Slit Lamp 40H LED

Desktop optical diagnostic device for busy clinics or consulting rooms. Refraction and combi-unit ready. Integrated yellow filter. Built-in diffuser. On-board illumination control.

- LED and Halogen Bulb systems
- Magnification: x6, x10, x16, x25 & x40
- Slit Width: 0 to 12mm
- Slit Length: 12mm
- Varying aperture diameters
- **Effective for:** Glaucoma, Diabetes, ARMD, Cataracts & General Examinations



HOP1398 Keeler Slit Lamp 40H LED

HOP1399 Table leg, IEC input/socket, electric elevation with castors

### PSL One Portable Slit Lamp

Excellence in optics, value and portability are key benefits of the Keeler PSL One. Designed with 10x magnification and manufactured with the strength to withstand the daily traumas of the demanding ophthalmic environment.

Unique features such as the fixation targets, and the 1mm square light patch for assessing a/c flare set the new standard for Portable Slit Lamps.

- Precision machined aluminium chassis
- Advanced 10x optics
- Controllable illumination
- Big Slit Lamp features, great value
- **Effective for:** Glaucoma, Diabetes, & General Examinations



HLO075 PSL One Portable Slit Lamp

### PSL Classic Portable Slit Lamp

The PSL Classic comes with 10x and 16x Magnification for greater acuity. Keeler designed and manufactured with the strength to withstand the daily traumas of the demanding ophthalmic environment, the PSL is lightweight, durable and robust.

Unique features such as the fixation targets, and the 1mm square light patch for assessing a/c flare set the new standard for Portable Slit Lamps.

- Precision machined aluminium chassis
- Lightweight portable device
- Advanced optics, 10x and 16x magnification
- Controllable illumination
- Big Slit Lamp features, great value
- **Effective for:** Glaucoma, Diabetes, & General Examinations



HLO071 PSL Classic Portable Slit Lamp

### Keeler D KAT Applanation Tonometer

New to the Keeler product portfolio is the Digital Applanation Tonometer, (D-KAT). Designed and manufactured in the UK to the same exacting standards as all Keeler products, the Keeler D-KAT delivers reliability and ease of use.

It operates according to the 'Goldmann method'. With less moving parts, the D-KAT is more reliable and accurate with recalibration just taking a few seconds.

HOP1273 Keeler D KAT Applanation Tonometer £1,290.79



## Test cards and Test Types

### Letter Test Card

Portable 3 metre test card with various type sizes

### Finesse Single Sided Test Type 3m/6m

Internally illuminated type panels with spot lights included

HOP178 Finesse Single Sided Test Type 3m - Direct

HOP179 Finesse Single Sided Test Type 6m - Indirect

HOP739 Letter Test Card

HOP739



HOP178



HOP179

## Multi-Sided Finesse Test Types

### Finesse/Elite

An all purpose, internally illuminated, infrared, remote controlled indirect test type. The Elite comes with additional Fan and Block for measurement of astigmatism.

### Four Sided

Internally illuminated with four upper Snellen panels and four lower panels.

HOP176.3 Wall Mounted Four Sided Manual Test Type - Direct

HOP175 Four Sided Manual Test Type - Indirect

HOP177 Four Sided Wired Remote Test Type - Indirect/Direct

HOP177.1 Four Sided Wired Remote Test Type - Indirect



## Vision Testing Charts

Various vision test charts for direct and/or indirect viewing from varying distances.

HOP180 Snellen 6m Test Chart AOE Direct

HOP181 Snellen 6m Test Chart AOE Indirect

HOP182 Snellen 6m Test Chart HAL Direct

HOP183 Snellen 6m Test Chart HAL Indirect

HOP184 Snellen 6m Test Chart TOY Reversible

HOP188 Sussex Vision 3m Tests

HOP189 Sussex Vision Test Types

HOP189.1 Sussex Vision 6m Test Chart OAX & Kindergarten

HOP190 Sussex Vision Reading Test Types

HOP190.1 Sussex Vision 3m Illuminated System



HOP194 Kindergarten Picture Test



HOP195 6m Keeler Elliot Picture Test

## Vision Testing Accessories

Vision testing accessories including wall mirrors

HOP400 Single Sided Test Type 3m

HOP401 Single Sided Test Type 6m

HOP402 Fixed Wall Mirror

HOP403 Adjustable Wall Mirror

HOP406 Vocational Reading Test

HOP407 4 Page Washable Reading Test







## Colour Vision Testing

Long established commercial / industrial colour screening. Patients must identify numbers or patterns formed in a matrix of small coloured dots varying in colour and intensity (psuedo-isochromatic plates).

HLO771	Stereo Optical Fly Stereotest
HLO772	Stereo Optical Butterfly Stereotest
HOP203	Ishihara 14 Plates – Concise 2 Plates for Illiterates
HOP204	Ishihara 24 Plates – Abridged 8 Plates for Illiterates
HOP205	Ishihara 38 Plates – Concise 8 Plates for Illiterates
HOP205.1	Ishihara Type Colour Test – 38 Plates
HOP206	City University Colour Vision Test
HOP206.1	Recording Charts

## Easyton Disposable Prisms

- Single use prisms for all Goldman style applanation tonometers
- Excellent value



HLO059 Easyton Disposable Prisms – 100pk

## Elite Test Chart

This ELITE plug-in adaptor allows you to transform any LCD monitor or TV set into an acuity chart by HDMI or VGA connection. Works out of the box, plug and play.



HLO224.1	Elite Plug in Test Chart (No Monitor)
HLO224	Elite Test Chart with 27" Monitor and Wall Bracket

## Childs Eye Tests

### Thomas the Tank Eye Tests

Keep in the fun in 'Near Vision Testing' with coloured pictures and easy to follow text that encourages full child participation

### LogMAR Crowded Tests

More subtle definition of changes between acuity ranges specifically in amblyopic children. Ideal for testing acuity of children from 3 years of age.

- 3m working distance
- 4 letters at each acuity level from 6/3 to 6/38



HOP192	Thomas the Tank Engine Reading Test Type
HOP591	LogMAR Crowded Test

## Near Vision Unit with Visor and Remote

### Refractive test includes:

- Measurement of visual acuity using Snellen letter and illiterate E-chart and Times Roman reading types.
- Accurate determination of presbyopic additions and other near corrections
- Near vision astigmatism tests
- Amplitude of accommodation including monocular measurements under binocular conditions

### The Binocular Balance includes:

- Fixation disparity test for uncompensated heterophoria
- motor eye dominance – convergence relationship
- Quantitative evaluation of foveal suppression in heterophoria patients
- Near point of convergence
- Targets for subjective cover tests for heterophoria and harmonious ARC



HLO218 Near Vision Unit - Infra-red Remote with Visor

## Grafton Full Aperture Set

- The Full Aperture Set is manufactured to CE standards
- The flat lenses fit easily in all trial frames
- The carry case holds all the lenses securely when moved.
- Full 268 piece set
- Choice of Chrome surround or Red / Black
- All accessory lenses included
- Carry case included



**HLO061** Full Aperture Trial Lens Set (Chrome Metal Rim)

## Grafton Reduced Aperture Set

- The Reduced Aperture Set is manufactured to CE standards
- The flat lenses are mounted in a safe, quality plastic surround
- The colour coded lenses are easy to identify
- Full 268 piece set
- Colour coded for plus and minus
- All accessory lenses included
- Carry case included



**HLO062** Reduced Aperture Trial Lens Set

## Premium Trial Lens Set

### 232 reduced aperture lenses in wooden case

All lenses are marked on both sides so you don't need to think about left and right lenses.

- Cylinder lenses have axis markings on the lenses
- Supplied in wooden case with removable tray
- Supplied with metal rim lenses as standard



**HLO154** Premium Trial Lens Set

## Spectra Iris Indirect

The Spectra Iris Indirect Ophthalmoscope is an AC or battery-powered device containing illumination and viewing optics; and it is intended to be used to examine the cornea, aqueous, lens, vitreous and retina of the eye.

- Affordability without compromising on Keeler Optics quality for the clearest view
- Durability with a secure carry case as a standard for your indirect and condensing lenses
- Portability that can slip into a carry case, your pocket or around your neck at only 132g



**HOP1274** Spectra Iris Indirect

## PSL Classic Aluminium Carry Case

- Protect your investment with a rugged aluminium carrying case
- Perfect when your Slit Lamp is not in use or when you are travelling.
- Lightweight with a pre cut foam insert for protection.



**HLO151** PSL Classic Aluminium Carry Case

## Inami Universal Trial Frame

Excellent quality, light weight adult trial frame.

Please specify colour choice when ordering



**HL0794** Trial Frame - White, Black or Lilac

## Oculus Univeral Trial Frame

- Universal product
- Lightweight and comfortable trial frame



**HLO153** Oculus Univeral Trial Frame

## Oculus Half Eye Adj. Bridge



**HLO064**

**HLO064** Oculus Half Eye

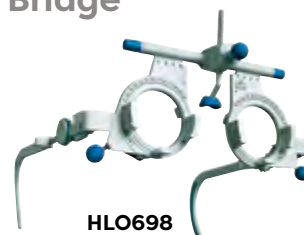

**HLO698**

**HLO773** TF42500 - New Oculus UB4 Trial Frame

## Diamond Diagnostic Lenses

- Lens material is special Schott Optical Glass
- Lens has several layers of professional AR coating (anti-reflection film)
- Available in Blue and Red



HLO698	Diamond 78D Aspheric Lens
HLO699	Diamond 90D Aspheric Lens

## Diamond 20D lens

- Features 3.13x magnification with a 46 degree field of view
- Made of high quality optical glass, finished with anti-reflection coating.
- Can be used with a slit lamp or binocular ophthalmoscope to diagnose the rear and bottom of the eye's vitreous body.



HLO022	Diamond 20D lens
--------	------------------

## Volk Lenses



HLO072	Volk G2 Trabeculum
HLO073	Volk 3 Mirror
HLO073.1	Volk G3 Goniofundus
HLO074	Volk G4 Goniolaser 28.5mm
HLO688	Volk Digital High Mag
HLO689	Volk Digital Wide Field Lens
HLO696	Volk 78D Lens



HLO690	Volk Digital 1.0x Imaging Lens
HLO691	Volk Super Pupil Lens
HLO692	Volk Super Vitreo Fundus Lens
HLO693	Volk Super Field Lens
HLO694	Volk Super 66 Lens
HLO697	Volk 60 Diopter Clear Lens

## DGH A Scan

The DGH6000 Scanmate-A combines the accuracy of DGH's proven A-Scan alignment algorithm with the processing power, data storage and connectivity of a personal computer.

Patient Data can be stored on a local computer or in a centralised network location where it can be accessed by multiple users. Patient records are fully searchable and can be exported in a format that is compatible with EMR/EHR systems.

The IOL Calculator is easy to use and includes modern formulas such as SRK®T, Hoffer® Q, Holladay 1 and Haigis. Lens constants can be optimised automatically based on Post-Operative results.

- Portable USB A Scan
- Contact and Water immersion modes
- Multiple IOL Formulas including Post-Refractive
- Customisable Reports
- Centralised storage of Patient Records in a Networked Office
- Integrates seamlessly with the DGH8000 B-Scan



HLO215	DGH A Scan
--------	------------

## RS5000 Digital LED Slit Lamp

Newly designed wide-field optics and high-tech illumination for ease of use, designed perfectly for daily eye exams.

- Features 12° convergence optics for easy image fusion. Newly designed optical alignment affords wider visibility in eyepiece.
- Built-in yellow filter which may be conveniently switched in/ out quickly for fluorescein techniques
- The new wide field optics have successfully increased the actual field of view up to 37, 23, 14.6, 9.5 & 5.9mm
- The new high-point eyepiece feature means that eye exams are performed in a more natural, comfortable position
- Joystick with camera shutter control, brightness control knob and locking control knob, routinely used functions all conveniently located for ease of use.
- Improved illumination pathway to increase overall luminance
- Wider slit width and longer slit height capability are attractive features when combined with the new wide field optics
- Forward and back movement is increased up to 100mm allowing exams with diagnostic and therapeutic fundus lenses



HLO798	RS5000 LED Slit Lamp
--------	----------------------

## Grafton Motorised Chair

- The Grafton Deluxe Chair features tip up arms and footplate
- The headrest is fully adjustable, ideal for applanation tonometry
- Side control locks allow recline and rotation
- Height control is by a footswitch that can be positioned to suit the operator



HL0054 Grafton Motorised Chair

## Grafton Electric Table

The Grafton TATET20 Electrical Instrument Table has been designed to take a variety of table tops to support one or two instruments, depending on your requirements.

The single white table top shown in the picture is included in the price, and a double table top is charged as extra.



HL0795 Electric Table (for lightweight items)

## Grafton Low Base Electric Table

**Low base, electrical instrument table with your choice of single or double width top.**

The Grafton low base electric instrument table offers smooth and quiet operation and a single column support.

- Elevation range: 606~806mm
- Maximum load: 50KG
- Net weight: 19KG
- Voltage: AC 115/230
- Frequency: 50/60Hz

**Single/double table tops are available separately (see below).**

**NOT SUPPLIED WITH TABLE TOP**



HL0795.1 Electric Table 550 Low Base (Top Purchased Separately)

HL0795.2 Single Top For 550 Table

HL0795.3 Double Top For 550 Table

## Inami Applanation Tonometer

The Inami Mod-T Plate Mount Applanation Tonometer operates according to the 'Goldmann method', by measuring intraocular pressure from the force required to flatten (applanate) a constant area of the cornea.

The T-Type model, which fits most slit lamps and uses applanation prisms, fixes onto the guide plate on the optical axis for the microscope and illumination unit arm.

- The Mod R + T Applanation Tonometers fit on to most slit lamps, both use the applanation prism
- The R model 'swings in' and can be permanently left mounted on the post that fits to the eyepiece
- The T Model sits on the tonometer plate which is further down on the slit lamp body



HL0041 Inami Applanation Tonometer - Head Mounted

HL0042 Inami Applanation Tonometer - Plate Mounted

## NFC-600 Retinal Camera

A portable, fully automatic, all in one non-mydratic retinal camera; providing high quality retinal images for remote screening areas and telehealth.

- High resolution of 12 million pixels, capturing and generating high quality retinal images.
- Uses retinal diagnostic staff and AI systems for more precise and helpful info, increasing diagnostic accuracy and efficiency.
- The image can be enlarged to see tiny details. Users can also change colors or apply photo effects to the image for different purposes.
- Ten internal fixation targets are selectable. The disc, fovea, macular, or other peripheral retina areas can be captured by selecting the specified fixation.
- Easily connected to any Windows-based PC or laptop via USB
- Provides red-free, negative film, RGB, grey scale filters for users to change or apply photo effects to the image.



HLO018 Portable Auto Non-mydratic Retinal Camera

## NFC-700 Retinal Camera

Features fully automatic 3D tracking and image capture and is an essential diagnostic instrument for ophthalmologists to evaluate and record a patient's retina. With its non-mydratic function, patient comfort is maximised during the diagnosis.

- Store, retrieve, archive and share images via USB or LAN. DICOM compliant, easy to integrate with PACS programs.
- Multi-image mosaics to see the broader view of the retina.
- Provides red-free, negative film, RGB, grey scale filters for users to change or apply photo effects to the image.
- Touch panel is easy to control - image details can be viewed and checked directly and precisely through the large screen.
- Ten internal fixation targets are selectable. The disc, fovea, macular, or other peripheral retina areas can be captured by selecting the specified fixation.
- The system automatically calculates the C/D ratio after cup and disc are marked, which helps practitioners to detect glaucoma or other abnormalities.



HLO797 Automatic Non Mydratic Retinal Camera

## FundusVue Reintal Camera

**Provides vivid color, high definition retinal images**

The latest generation of non-mydratic fundus camera is designed to capture and provide images of the eye as an aid to clinicians in the diagnosis of diabetic retinopathy, AMD, glaucoma and other retinal diseases.

- Dedicated FundusVue software speeds up image capture with live previews. The entire process takes only a few minutes.
- Multiple controls and settings are not necessary with the FundusVue. Internal fixation lights and self-guiding software assist the user in capturing high quality images.
- Weighing only 2Kg, FundusVue's compact design saves on setup space and can be easily transported wherever needed.
- The software allows users to store, retrieve, archive, process and share the digital images instantly, with just a mouse click.
- Simple USB connection allows flexibility as to where examinations take place, with easy transfer of data.



HLO019 Manual Non-mydratic Retinal Camera

## CrystalVue Tonovue

**Automatic Non-Contact Tonometer with 3D tracking technique, multiple IOP measurements with a single tap.**

- Auto-tracking and auto-alignment with one tap on the pupil.
- Softer and quieter air puff reduces the discomfort for patient.
- FDA 510(k), CE MDD 93/42/EEC, TFDA & CFDA certified.
- Click 'start', the exam will begin and the result will be printed.
- Large 8" screen and touch panel is easy to control, making IOP measurement simple and fast. It also makes input, search, and display of the patients' database easy.
- Users are able to select either automatic or manual mode, set 1-3 times of measurements, and adjust IOP range based on their preference and patients 'needs.
- The measurements can be printed out automatically by thermal printer, and then be nicely cut by the auto cutter.



HLO020.1

HLO020 CrystalVue Tonovue Auto NCT

HLO020.1 CrystalVue Tonovue with Pachymetry

## LED Slit Lamp

- Warm light source with 14mm aperture
- PWM brightness control and colour temperature stability
- Continuously adjustable illumination
- Microscope type: Parallel type, Galilean system
- Magnification Changer: Revolving drum
- Eyepiece magnification: 12.5x
- Magnification: 6x, 10x, 16x, 25x, 40x
- Diopter: -7D +7D
- Pupil Range: 52mm – 82mm
- Visual Field Diameter: 6x 33mm; 10x 22mm; 16x 14mm; 25x 8.5mm; 40x 5.5mm
- Illumination type: Haag Streit type
- Slit Image Width: 0mm – 14mm continuously adjustable
- Slit Image Length: 1mm – 14mm continuously adjustable
- Slit Image Angle: 0 – 180 degree continuously adjustable
- Illumination Tilting: 5, 10, 15 & 20 degrees
- Slit Aperture Size: 0.2, 1, 3, 5, 10 & 14mm
- Filter: Heat Absorption, Grey, Red Free (green), Cobalt Blue



HLO799 LED Slit Lamp



## Frey Auto Perimeter

The AP-50 uses LED back projection of stimuli in white colour, and offers a wide range of strategies, test fields and test parameters to assure quick and precise measurement. The AP-50 is Compatible with any PC computer running Windows.

Built-in data analysis includes regression analysis and standardised presentation and printing of examination results.

### Small device size with extensive features

The elliptically shaped measurement bowl significantly reduces the device size, yet the diagnostic value of the device is comparable to a full field perimeter. Full central 30° of patient vision with extension to 50° temporally allows precise test nasal step where early glaucoma often commences.

### Binocular testing

AP-50 fulfils specific visual field testing requirements for drivers and occupational medicine. Measurement range covers up to 160° temporally, and both eyes can be tested simultaneously.

### Compact and lightweight design

The AP-50 measures 548 x 382 x 450 mm and weighs only 9kg, making it an ideal desktop clinical tool which can be easily transported, set up and installed.



### Less need for ambient light conditions

The elliptically shaped measurement bowl requires lower test room illumination conditions. Electronically controlled background illumination ensures stable measurement conditions.

### Standard test fields and conditions

Standard test fields including central 30, central 24, and macula are available and all tests allow for easy data comparison with other perimeter systems. Dedicated glaucoma tests are included.

HLO800 Frey Auto Perimeter

## Lensmeter Internal Reading

Value for money, good quality Lensmeter with combined Circle of Dots and Cross Line Target. Internal reading facility able to read most large lenses and Spectacle Frames.



HLO211 Lensmeter Internal Reading

## Auto Lensmeter

Compact Auto Lensmeter which includes Progressive, PD and UV measurements. Compact design with built in printer.

- UV Measurement
- Progressive Lens measurement and detection
- PD measurement
- 5.7" High Resolution Screen
- Green LED Light Source
- Hartman Testing Method
- High specification
- Simple and easy to use
- Automatic reading and memory of data



HLO212 Auto Lensmeter AL900

## Inami Goldman Type Perimeter

Provides precise kinetic quantitative perimetry. Advanced technology providing precise measurements and efficient illumination. Telescope and shutter device with a light meter for checking target illumination.

- **Neutral density filters:**
  - A:** 0.0315, 0.10, 0.315, 1.00
  - B:** 0.40, 0.50, 0.63, 0.80, 1.00
  - C:** 0.01, 0.0001
- **Power:** 100, 110, 240V AC50/60Hz
- **Target sizes:** 1/16, 1/4, 1, 4, 16, 64mm<sup>2</sup>
- **Lamp:** 6V 30W (L1550V1)
- **Dimensions & weight:** 700 x 540 x 930mm, 38kgs

HLO227 Inami Goldman Type Perimeter



## Shin Nippon DL1000 Auto Lensmeter

A compact multi functional lensmeter, using the latest technology. The DL1000 automatically calculates the %UV transmission and displays results on screen. PD distances are measured using the unique 'Dual Nose Pad' frame holder. The 'tiltable' TFT colour screen suits all users and ensures the perfect view. Auto progressive lens detection speeds up the process when working with progressive lenses.

- Compact design
- UV measurement
- PD function
- Large colour screen
- Auto progressive mode
- Built in printer
- Fast and accurate



HLO787 Shin Nippon DL1000 Auto Lensmeter

## Shin Nippon XL1 Hand Held Slit Lamp

The new XL1 Hand Held Slit Lamp from Shin Nippon is the lightest and brightest on the market. The latest LED illumination technology provides a brilliant white light whilst the absence of the conventional bulb and bulb holder results in a very light and easy to use instrument.

The XL1 is supplied complete with strong metal carry case, charger and battery LED light source lasts for over 50,000 hours & 10X and 16X eyepieces included

- Slit width is always variable
- Filters include: cobalt blue, green, and heat filter
- 2 Hour Battery life
- Trigger switch ensures the lamp cannot be left on
- Illumination control
- 10x and 16x Eyepieces
- Lightest and brightest on the market



HLO060 Shin Nippon XL1 Hand Held Portable Slit Lamp

## HENSON 9000 Visual Fields Analyser

**Enhanced visual field screening and analysis for accurate and efficient glaucoma management**

Offers sensitive, specific and fast suprathreshold and threshold screening. Standard single stimulus screening tests or the faster, patient-preferred multiple stimulus versions are available, allowing operators to re-test missed stimuli and/or extend patterns in-test, to rule out false positives with a new level of confidence. It also boasts the ZATA threshold algorithm.

- Modern, ergonomic design which is EMR compatible
- SAP white-on-white testing
- Customise single/multiple stimulus suprathreshold screening
- 26, 68 & 136 point suprathreshold patterns (extendable in-test)
- 10-2, 24-2 & 30-2 threshold test patterns (extendable in-test)
- 60° (monocular) / 160° (binocular) testing range
- ZATA threshold test using prior patient data

### Efficient glaucoma management

Faster, patient-friendly multiple stimulus tests reduce false positives, with no impact on sensitivity, whilst the ZATA threshold algorithm is uniquely able to build on prior patient data for ongoing glaucoma monitoring, rather than starting from age normative data every time – as other perimeters do.

- **Put patients first**  
Customisable screening and threshold testing using prior data
- **Enhance efficiency**  
fast tests save valuable time with no impact on sensitivity
- **Streamline services**  
ease-of-use enables operability by staff at all levels



HLO805 HENSON 9000 Visual Fields Analyser

## Shin Nippon K900 Auto Refractor / Keratometer

The new Slim, Compact and Stylish Accuref K-900 from Shin Nippon stands out from the crowd featuring a Screen with a swivel function to the left of 30° and vertical tilt function of 40°.

### Exquisite detail and quality.

Sophisticated shape combined with soft curves and the attractive color with high quality metallic and pearlescent paintwork which complements any interior and appeals atmosphere of trust to the customer.

### Optical Unit

The optical unit allows measurement of minimum pupil diameter up to 2.0mm. It's touch sensor button enables sensitive and accurate operation, the redesigned joystick allows the operator to control the unit with more precise and instinctive movement.

The modified shape of the forehead rest and the chin rest help to minimise stress on the patient.

- Slim, compact and stylish Design that is easy to use
- Redesigned joystick allowing precise movement
- Modified shape of the forehead rest and the chin rest



HLO221 Shin Nippon K900 Auto Refractor / Keratometer

## HEINE® SIGMA 250 Binocular Indirect Ophthalmoscope

Two separate controls for selecting the ideal setting of parallax and convergence guarantee completely illuminated stereo views in pupils up to 2 mm, as well as viewing in the periphery. The illumination beam can be adjusted by ±3° to eliminate reflexes.

- Extremely light, 110 g without frame
- The standard in LED illumination defining optimal light intensity, homogeneity and colour rendering for each situation
- Lightweight frame. High tensile carbon fibre construction is lightweight and has excellent durability and stability.
- Integrated red-free filter to improve contrast
- Detachable blue & yellow filters
- Dust proof and maintenance-free
- PD selection from 47 to 72 mm
- Optics on swivel mount for an unrestricted view
- Optional clip-in correction frame for prescription lenses
- Apertures: Large and small aperture or M2 micro spot instead of small aperture for M2 kits.
- **SIGMA 250 Kit Comprises:**  
SIGMA 250, S-FRAME, Retaining Cord & Cleaning Fluid
- **SIGMA 250 Set Comprises:**  
SIGMA 250, S-FRAME, mPack mini with E4-USB plug-in transformer and USB cord, Scleral Depressor Small, Scleral Depressor Large, A.R. 20 D Ophthalmology Lens, Teaching Mirror, Blue and Yellow Filters Diffusor, mPack mini Belt Clip, Retaining cord, Cleaning Fluid and Carrying Case



**HEINE** QUALITY



LED NOW IN HEINE QUALITY.



HLO206	HEINE SIGMA 250 Kit with S-Frame
HLO207	HEINE SIGMA 250 M2 Kit with S-Frame
HLO208	HEINE SIGMA 250 Set with S-Frame
HLO209	HEINE SIGMA 250 M2 Set with S-Frame

HOP1406	mPack mini with Li-on recharge battery & E4-USB transformer	£309.91
HOP1407	mPack mini with Li-on recharge battery only	
HOP1408	mPack mini Belt Clip	
HOP1409	USB cord & E4-USB transformer	
HOP1410	E4-USB - Medical approved plug-in power supply for USB cord	

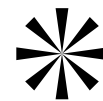

LIGHT INTENSITY

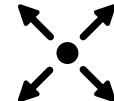

HOMOGENEITY

**CRI 90**

COLOUR RENDERING

**LONG LIFE**

DURABILITY



CONVERGENCE / PARALLAX ADJUSTMENT



THERMAL MANAGEMENT



# HEINE® OMEGA 600 Indirect Ophthalmoscope



We've developed the HEINE OMEGA 600, based on valuable physicians' input.

The new HEINE OMEGA 600 is the lightest high-end indirect ophthalmoscope and offers the best wearing comfort. The extremely compact lithium polymer battery delivers absolutely top performance with up to 8 hours of operating time. With all cables and electronics integrated in the new headband, this ophthalmoscope is the state of the art.

visionBOOST for cataract patients: more confidence in the diagnosis when examining patients with media opacities. Proven to deliver up to 20% better view of the retina in patients with cataracts\*: no matter what circumstances – always the ideal working brightness for both the patient and the user.

- Best 3D imaging due to our unique Stereoscopic Adjustment Technology in dilated and undilated pupils, and even with prematures and newborns
- Personalised fit: ergonomic positioning of controls and levers, adaptable for right and left handed users, flip-up function for more convenient patient interactions
- Easy and effective disinfection thanks to smoothSURFACE: no openings, integrated electronics
- Long-lasting investment due to its robust design: legendary HEINE durability, maintenance-free (dustproof optics), optics firmly mounted on an aluminium frame, unique thermal management of LEDHQ
- Apertures: HEINE Diffusor, small, medium and large spot
- Filters: yellow (for light sensitive patients), red-free and blue



HOP060 OMEGA 600 with battery, +2D/OD eyepieces & E4-USBC £2,794.50

## HEINE® OMEGA 600 Sets

The new HEINE OMEGA 600 is available in a range of sets to suit varying needs. Please see details below:

### OMEGA 600 WALL CHARGER SET:

Indirect Ophthalmoscope (with battery, +2D/OD eyepieces & E4-USBC power supply & cable) and CW1 wall charger

### OMEGA 600 TRAVELLER SET:

Indirect Ophthalmoscope (with battery, +2D/OD eyepieces & E4-USBC power supply & cable) and traveller bag

### OMEGA 600 STUDENT SET:

Indirect Ophthalmoscope (with battery, +2D/OD eyepieces & E4-USBC power supply & cable), TM1 teaching mirror and traveller bag

### OMEGA 600 CHARGING SET:

CC1 charging case and CB1 charging battery



HOP071 OMEGA 600 Wall Charger Set

HOP072 OMEGA 600 Traveller Set

HOP073 OMEGA 600 Student Set

HOP074 OMEGA 600 Charging Set



HOP067

HOP063



HOP066



HOP064



HOP065

HOP061/2



HOP066 CW1 wall charger

HOP063 CC1 charging case

HOP064 CB1 charging battery

HOP065 E4-USBC power supply with cable

HOP067 OMEGA 600 Travelling Bag

HOP068 TM1 teaching mirror with case

HOP069 OMEGA 600 Eyepiece +2D

HOP070 OMEGA 600 Eyepiece 0D

## AccoView 300 LED Diagnostic Sets

A lightweight, pocket-sized LED illumination diagnostic set. Advanced optics ensures excellent illumination and accuracy of diagnosis in every examination.

Built from impact resistant, re-enforced plastics to ensure durability, reliability and a long working life. Supplied with compact handle designed with built-in pocket clip.

### 300 LED Ophthalmoscope

- Bright, long lasting LED illumination
- A selection of 5 varying apertures
- Color coded 18 lenses for excellent resolution

### 300 LED Otoscope

- Distal Fiber Optic LED illumination
- Swivel type window with 3x magnification lens for sharp images and minimal reflection.
- Insufflation port for pneumatic testing of tympanic mobility.

Individual otoscopes and ophthalmoscopes are available with 300 handle supplied either in a soft protective pouch or hard secure case.

### Complete Diagnostic sets

Supplied with both ophthalmoscope and otoscope, available in hard secure case with choice of single or dual handles as required.

**HOP075** AccoView 300 Otoscope with Handle in Soft Pouch

**HOP076** AccoView 300 Otoscope with Handle in Hard Case

**HOP077** AccoView 300 Ophthalmoscope with Handle in Soft Pouch

**HOP078** AccoView 300 Ophthalmoscope with Handle in Hard Case

**HOP079** AccoView 300 Diagnostic Set with 1x Handle in Hard Case

**HOP080** AccoView 300 Diagnostic Set with 2x Handles in Hard Case

ACCOSON



Made in the UK



## AccoView Plus Charging Station

### Desktop versatile diagnostic set charging station

Dual slot handle charger capable of charging either of the AccoView handles (Classic/Premier).

Desk stand includes two bright OLED displays to easily identify current percentage battery charge status for either handle.

OLED display is also capable of indicating if there are any issues that may interrupt charging, such as reverse polarity.

When the battery is fully charged the charger with automatically cut off power supply to the handle, ensuring both safety and the preservation of handle battery life.

- Input power supply 100-250VAC, 50/60Hz
- Dual charging ports, isolated for safety and performance
- Internal microcontroller manages both charging and status display information
- OLED displays help indicate battery charge levels
- Auto-off charging when at 100%

**HOP086** AccoView Plus Charging Station

ACCOSON



Made in the UK



## AccoView 500 LED Classic FO Sets

Our premium quality pocket-sized with enhanced features, LED illumination and 2.5v classic handles.

### Otoscope

- Neutral white LED light with a brightness of 75,000 Lux
- CRI ≥ 95 and Red index ≥ 90 for true colour visualization
- Distal fibre optic illumination
- Swivel-type window with AR coated 4x lens for clarity
- Insufflation port for pneumatic testing of tympanic membrane

### Ophthalmoscope

- Sealed, dustproof design protects precision and ensures both reliability and extends working-life.
- Neutral white LED light with a brightness of 7,000 Lux
- CRI ≥ 90 and Red index ≥ 90 for true colour visualization
- Coaxial optics produce shadow-free spot for easier entry into undilated pupils and a larger field of view
- 7 Apertures for generalist use as needed



**HOP081** AccoView 500 Classic Fibre Optic Otoscope Set - LED 2.5V

**HOP082** AccoView 500GE Classic Ophthalmoscope Set - LED 2.5V

**HOP083** AccoView 500SE Classic Fibre Optic Diagnostic Set - LED 2.5V

## AccoView 500 LED Premier FO Set

The premium AccoView 500 diagnostic set is also available with new Premier 3.5v handles.

This set includes both the 500 Otoscope and 500 Ophthalmoscope heads (as detailed in prior product listing) and is supplied with enhanced, black Premier handles in a secure storage case.

### Premier Diagnostic Set

- Includes both Accoview 500 Otoscope and Ophthalmoscope heads
- USB-C type charger input to easily charge handles
- 3.5v handle power
- Enhanced brightness control by twisting handle head, dimming is stepless and gradual
- Ergonomically designed for easy placement of thumb
- Handle can be turned off with a continuous twist of the Knob for three seconds in clock wise direction
- Handle automatically turns off after 3 minutes of idle state for enhanced safety of the bulb and battery life



**HOP084** AccoView 500SE Premier Fibre Optic Diagnostic Set - LED 3.5V

## AccoView 500 LED Diagnostic Station

A comprehensive wall-mounted solution for hospital and clinic environments. A modern, modular design to serve the needs of practitioners.

This diagnostic station features two premier accoview handles with accompanying fibre optic LED Otoscope and Ophthalmoscope heads. In addition to this the unit also includes a dispenser for Otoscope single-use ear tips.

A separate wall board is available for easy mounting of the complete unit. An excellent feature is if the unit needs to be removed for maintenance of the facility or moving to another place.

- Automatic on/off of handle power when removed from cradle
- 3m spiral cord allows comfortable use from different angles for each of the instruments
- Replacement ear tip dispenser offers quick, convenient replacement of Otoscope ear tips.

**HOP085** AccoView Diagnostic Station with Tip Dispenser

**HOP085.1** AccoView Diagnostic Station with Tip Dispenser & Thermometry



## Welch Allyn® Ophthalmoscopes

Welch Allyn® Ophthalmoscopes generally feature multiple aperture/filter options, combined with bright, vibrant light providing long-lasting, reliable performance for general and specialist examinations.

**Baxter**

This vast range of versatile Ophthalmoscopes, otoscopes and relating accessories provide both economic and effective solutions.

### Welch Allyn® Aperture Key

The Welch Allyn® range of ophthalmoscopes and otoscopes feature a range of apertures/filters. These apertures and their uses can be found here.



#### SMALL APERTURE

Provides excellent view of fundus through an undilated pupil.



#### FIXATION APERTURE

Has graduated cross-hairs for measuring eccentric fixation or locating lesions.



#### SLIT APERTURE

Used to determine levels of lesions and tumors.



#### RED-FREE APERTURE

For easy identification of veins, arteries and also nerve fibers.

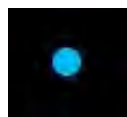

#### COBALT FILTER

Used with dye to view small lesions, abrasions, etc. on the cornea.



#### MICRO-SPOT APERTURE

Allows quick entry into small, undilated pupils.

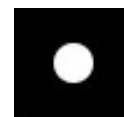

#### LARGE APERTURE

Standard aperture for a dilated pupil and general examination of the eye.

### Welch Allyn PanOptic™ Plus Ophthalmoscope

This direct ophthalmoscope boasts a 20X larger viewing area. When compared to the view through a standard ophthalmoscope, these are views you have to see.

With Quick Eye™ alignment technology, to help direct patient gaze for better optic disc alignment. Paired with long-lasting LED lamps, and DuraShock™ technology, upgrade from your standard or pocket ophthalmoscope to enhance your eye exams.

- 20X larger viewing area when compared to a standard or pocket ophthalmoscope
- Long-lasting LED illumination cuts down on need for lamp replacement
- Quick Eye alignment lights on the patient side help you direct patient gaze
- Compatible with all Welch Allyn 3.5 V power handles and wall transformers

**Baxter**



5 Year Warranty



**HOP003** PanOptic™ Plus LED Ophthalmoscope for iExaminer

**HOP003.1** PanOptic™ Plus LED Basic Ophthalmoscope

**HOP1079** iExaminer SmartBracket

### Welch Allyn MacroView® Plus Otoscope

Offers a 3X larger viewing area for ear exams when compared to views through a standard or pocket otoscope.

When paired with long-lasting LED illumination and our new LumiView™ Clear Single-Use Ear Specula, experience up to 8x brighter views than those seen through a black ear speculum.

With the power to move from optical to digital, you can capture and share images for consultation, when using the MacroView Plus otoscope and our Welch Allyn iExaminer® SmartBracket™ paired with a smart device and our iExaminer Pro App.

- Focus-free design
- Long-lasting LED illumination
- For brighter views, pair with LumiView Clear Ear Specula
- MacroView Plus otoscope models are digitally-capable, for capturing and sharing images of the ear

**Baxter**



5 Year Warranty



**HOP004** MacroView® Plus Otoscope for iExaminer

**HOP004.1** MacroView® Plus Basic Otoscope

**HOP1079** iExaminer SmartBracket

## Welch Allyn 3.5V LED Diagnostic Set

Try sets with our new Welch Allyn PanOptic™ Plus Ophthalmoscope and MacroView® Plus Otoscope.

Our innovative wide-view optical technologies provide a larger area when viewing the optic disc and tympanic membrane. Look for our diagnostic sets that feature longer-lasting power handles and LEDs, for more dependable tools to keep you running.

- Compatible with any Welch Allyn 3.5v handles
- Sets include 3.5v handle, USB Charger and case
- Apertures: Small, Large, Red Free, Slit, Fixation Target, Cobalt Blue

**Baxter**



- HOP030** with PanOptic Plus LED Ophthalmoscope
- HOP031** with Coaxial LED Ophthalm. & MacroView Basic LED Otoscope
- HOP032** with MacroView Plus LED Otoscope for iExaminer

## Welch Allyn 3.5V LED PanOptic Desk Set

Pair your exams with our convenient, compact desk charging unit and exam tool sets. Drop-in desk/well charging Welch Allyn rechargeable power handles to help keep your otoscope, ophthalmoscope and other exam tools ready for use.

- Integrated light indicators highlight that power is flowing to the unit and that handles are charging
- Available with iExaminer® for use with the MacroView Plus otoscope to capture and share images of the ear
- Focus-free design
- Long-lasting LED illumination
- For brighter views, pair with LumiView Clear Ear Specula

**Baxter**



- HOP028** with PanOptic Basic LED Ophthalmoscope and MacroView Basic LED Otoscope
- HOP029** with PanOptic Basic LED Ophthalmoscope and MacroView Basic LED Otoscope for iExaminer

## Welch Allyn® Elite Diagnostic Set

The elite diagnostic set includes:

- Fibre Optic Otoscope
- 3.5v Coaxial Ophthalmoscope
- C-Cell battery handle
- Reusable specula (2mm, 3mm, 4mm and 5mm)
- Hard carry case

**Baxter**



- HOP001** Elite Diagnostic Set with C-Cell Handle
- HOP002** Elite Diagnostic Set with LED bulbs & C-Cell Handle
- HOP006** Elite Diagnostic Set with Lithium Ion Handle & Transformer

## Welch Allyn® 3.5v Professional Otoscope Set

- Fibre optic otoscope with HPX bulb for truer tissue colour
- 2.5 x magnification
- Insufflation port for pneumatic otoscopy
- Set includes c-cell handle, 4 reusable specula and a hard case

**Baxter**



- HOP528** Professional Otoscope Set with C-Cell Handle
- HOP654** Professional Otoscope (Head Only)
- HOP654.1** Professional Otoscope with LED Bulb (Head Only)
- HOP016** Halogen Replacement Bulb (03100-U)
- HOP643** Otoscope LED Replacement Bulb (03100-LED)

## Welch Allyn® 3.5v Elite Ophthalmoscope Set

- Coaxial vision system, sealed optics, and Halogen HPX or LED illumination for excellent views of the fundus
- Shadow-free spot, easier entry into undilated pupils and a larger field of view versus standard ophthalmoscopes
- Sealed optics keep out dust and dirt
- 18 unique aperture/filter combinations for greater versatility
- 28 focusing lenses with a range of -25 to +40 dioptres
- Comes with c-cell battery handle in a hard case
- Patented Welch Allyn coaxial system for easy entry and much wider field of view



**Baxter**



<b>HOP651</b>	Elite Ophthalmoscope (Head Only)
<b>HOP651.1</b>	Elite Ophthalmoscope with LED Bulb (Head Only)
<b>HOP652</b>	Elite Ophthalmoscope Set with C-Cell Handle
<b>HOP014</b>	Halogen HPX Replacement Bulb (04900-U)
<b>HOP645</b>	Ophthalmoscope LED Replacement Bulb (04900-LED)

## Welch Allyn® MacroView Otoroscope

- 4.2 x magnification - 30% greater than a traditional otoscope
- Set comes with C-cell handle and protective carry case
- Twice the field of view - see almost all the tympanic membrane without panning
- Adjustable focusing - suits different ear canal lengths and compensates for far-sighted eyes
- Insufflation port for pneumatic otoscopy
- Tip grip holds the specula firmly in place and gives ejection mechanism for hands-free disposal



**Baxter**



<b>HOP531</b>	MacroView Otoroscope Set with C-Cell Handle
<b>HOP655</b>	MacroView Otoroscope (Head Only)
<b>HOP655.1</b>	MacroView Otoroscope with LED Bulb (Head Only)
<b>HOP655.2</b>	MacroView Otoroscope (Head Only) with Throat Illuminator
<b>HOP476</b>	MacroView Halogen Replacement Bulb (06500-U)
<b>HOP644</b>	MacroView LED Replacement Bulb (6500-LED)

## Welch Allyn® Pocket LED Ophthalmoscope



One of the most durable ophthalmoscopes on the market; a reliable tool through your training and into practice. All the apertures and filters as in our full-size ophthalmoscopes, so you don't have to sacrifice any functionality

- Welch Allyn SureColor™ LED lamps come standard
- Lightest-weight Welch Allyn ophthalmoscope for portability and ease of use
- One of the most durable ophthalmoscopes on the market; a reliable tool through your training and into practice
- All the apertures and filters as in our full-size ophthalmoscopes, so you don't have to sacrifice any functionality

**Baxter**

Model:	Pocket LED	Pocket LED Plus
<b>Neutral Density Filter:</b>	No	Yes
<b>Handle Bumpers:</b>	Available	Set of 2 Incl.
<b>Protective Case:</b>	Not Included	Soft Case Incl.
<b>Warranty Length:</b>	3 Years	5 Years
<b>Product Code - BLACK:</b>	HOP1317	HOP1321
<b>Product Code - WHITE:</b>	HOP1318	HOP1322
<b>Product Code - PLUM:</b>	HOP1319	HOP1323
<b>Product Code - BLUE:</b>	HOP1320	HOP1324
<b>Product Price:</b>	<b>£140.00</b>	<b>£165.20</b>

### Accessories:

<b>HOP1314</b>	Coloured Bumper Accessory Kit - 4 sets
<b>HOP1315</b>	Soft Zip Case - Fits 2 Pocket LED Scopes & accessories

## Welch Allyn® Pocket LED Otoscope

Baxter



The Pocket LED Otoscope is the most durable pocket-style otoscope on the market today, designed to hold up through your training and into practice.

Examine your patients in style, with four colour options to choose from, and optional handle and window bumper accessory kit.

With a manufacturer warranty included you can rely on these pocket otoscopes for years to come.

- Lightest-weight Welch Allyn otoscope for comfort and control during examinations
- SureColor™ LED lamps come standard
- Fibre optics provide cool light with no reflections or obstructions
- Portable, to help you meet the challenges you face when treating patients
- **Colours:** Black, White, Plum and Blue

Model:	Pocket LED	Pocket LED Plus
<b>Light Output:</b>	3 Lumens	5.5 Lumens
<b>Neutral Density Filter:</b>	No	Yes
<b>Handle Bumpers:</b>	Available	Set of 2 Incl.
<b>Protective Case:</b>	Not Included	Soft Case Incl.
<b>Warranty Length:</b>	3 Years	5 Years
<b>Product Code – BLACK:</b>	HOP1306	HOP1310
<b>Product Code – WHITE:</b>	HOP1307	HOP1311
<b>Product Code – PLUM:</b>	HOP1308	HOP1312
<b>Product Code – BLUE:</b>	HOP1309	HOP1313

### Accessories:

**HOP1314** Coloured Bumper Accessory Kit – 4 sets

**HOP1315** Soft Zip Case - Fits 2 Pocket LED Scopes & accessories

## Welch Allyn® Pocket LED Diagnostic Set

Baxter

The Welch Allyn Pocket LED diagnostics combine function and style to provide maximum performance and durability in a compact set.

- The only pocket sets with advanced SureColor LED technology – provides true tissue colour rendition
- The only drop-resistant otoscope on the market
- Lightest 2 battery pocket sets available
- Get 30 x longer life from 2 AA batteries and LED bulbs do not require replacement
- Choose from 4 colours and personalise with unique, interchangeable accessories which also protect your devices
- **LED:** 2x handles, Soft case, 4x reusable specula & bumpers
- **LED Plus:** 2x handles, Hard case, Tube of ear specula, 8x handle bumpers & 4x window bumpers



HOP1331



HOP1332



HOP1325



HOP1326



HOP1327



HOP1328

Model:	Pocket LED	Pocket LED Plus
<b>Light Output:</b>	3 Lumens	3/5.5 Lumens
<b>Neutral Density Filter:</b>	No	Yes
<b>Handle Bumpers:</b>	Available	Set of 2 Incl.
<b>Protective Case:</b>	Not Included	Soft Case Incl.
<b>Warranty Length:</b>	3 Years	5 Years
<b>Product Code – BLACK:</b>	HOP1325	HOP1329
<b>Product Code – WHITE:</b>	HOP1326	HOP1330
<b>Product Code – PLUM:</b>	HOP1327	HOP1331
<b>Product Code – BLUE:</b>	HOP1328	HOP1332

### Accessories:

**HOP1314** Coloured Bumper Accessory Kit – 4 sets

**HOP1315** Soft Zip Case - Fits 2 Pocket LED Scopes & accessories

## Welch Allyn Pocket LED Otoscopes, Ophthalmoscopes and Sets

Maximum performance and durability in a compact set that travels easily with you from one patient to the next.



### Examine your patients in style

Choose from four colours and personalise with unique, interchangeable accessories which also protect your devices.



Pocket LED Sets with Soft Case



Pocket Plus LED Sets with Hard Case & Accessories





## Welch Allyn® 3.5v Prestige Diagnostic Set

**Baxter**



### Ophthalmoscope

- 3.5v Coaxial ophthalmoscope

### Otoscope

- MacroView otoscope has 4.2 x magnification – 30% greater than a traditional otoscope
- Twice the field of view – see almost all the tympanic membrane without panning
- Adjustable focusing – suits different ear canal lengths and compensates for far-sighted eyes

### Diagnostic Set

- C-cell battery handle & 4 reusable specula in a hard case



<b>HOP530</b>	Prestige Diagnostic Set with C-Cell Handle
<b>HOP534</b>	Prestige Diagnostic Set with LED bulbs & C-Cell Handle
<b>HOP476</b>	MacroView Halogen Replacement Bulb (06500-U)
<b>HOP644</b>	MacroView LED Replacement Bulb (6500-LED)
<b>HOP014</b>	Halogen HPX Replacement Bulb (04900-U)

## Welch Allyn® 3.5v Professional Diagnostic Set

**Baxter**



Welch Allyn Professional Diagnostic Set 3.5v with protective case and battery handle.

### Ophthalmoscope

- Ophthalmoscope has 6 diagnostic beams: small, medium & large spot, target, slit and red-free
- Dioptre range: +40 to -25

### Otoscope

- Fibre optic otoscope with HPX bulb for truer tissue colour
- 2.5 x magnification
- Insufflation port for pneumatic otoscopy

### Diagnostic Set

- Comes with c-cell battery handle & 4 reusable specula in a hard case



<b>HOP527</b>	Professional Diagnostic Set with C-Cell Handle
<b>HOP742</b>	Halogen Ophthalmoscope Replacement Bulb (03000-U)
<b>HOP016</b>	Halogen Replacement Bulb (03100-U)

## Welch Allyn® 3.5v Elite Desk Set

Unique coaxial ophthalmoscope allows easy entry to the eye and shadow-free viewing of the retina

- 6 beams: small, medium & large spot, target, slit and blue
- Red-free, and polarising filters
- Dioptre range: +40 to -25
- Double sealed, dust-free optics
- Fibre optic otoscope with HPX bulb for truer tissue colour
- 2.5 x magnification & integral throat illuminator
- Insufflation port for pneumatic otoscopy



**Baxter**



<b>HOP022</b>	Elite Desk Set with Ni-Cad handles
<b>HOP966</b>	Elite Lithium Ion Desk Set
<b>HOP014</b>	Halogen HPX Replacement Bulb (04900-U)
<b>HOP016</b>	Halogen Replacement Bulb (03100-U)
<b>HOP643</b>	Otoscope LED Replacement Bulb (03100-LED)
<b>HOP645</b>	Ophthalmoscope LED Replacement Bulb (04900-LED)

## Welch Allyn® 3.5v Prestige Desk Set

Unique coaxial ophthalmoscope allows easy entry to the eye and shadow-free viewing of the retina

- 6 beams: small, medium & large spot, target, slit and blue
- Red-free, and polarising filters
- Dioptre range: +40 to -25
- 4.2 x magnification, 30% greater than a traditional otoscope
- See almost all the tympanic membrane without panning
- Adjustable focusing to suit different ear canal lengths and compensate for far-sighted eyes
- Insufflation port for pneumatic otoscopy



**Baxter**



<b>HOP481</b>	Prestige Desk Set with Ni-Cad handles
<b>HOP964</b>	Prestige Lithium Ion Desk Set
<b>HOP014</b>	Halogen HPX Replacement Bulb (04900-U)
<b>HOP476</b>	MacroView Halogen Replacement Bulb (06500-U)
<b>HOP644</b>	MacroView LED Replacement Bulb (6500-LED)
<b>HOP645</b>	Ophthalmoscope LED Replacement Bulb (04900-LED)

## Welch Allyn® Green Series™ 777 Wall Unit

A reliable diagnostic solution that delivers accurate results whilst providing energy efficiency and cost savings.

- Auto on/off, saves time and energy, is also more hygienic
- Same wall mounting footprint for simple upgrade from 767
- Improved design, ideal for smaller clinics



**HOP1081** Wall Transformer (No heads)

**HOP1083** Elite with Coaxial Ophthalmoscope & Diagnostic Otolaryngoscope

**HOP1085** Prestige with Coaxial Ophthalmoscope & MacroView Otolaryngoscope



10 Year  
Warranty

**Baxter**

### Welch Allyn® Coaxial Ophthalmoscope

- 18 unique aperture/filter combinations for greater versatility
- 28 focussing lenses with a range of +40 to -25 dioptres



### Welch Allyn® Professional Otolaryngoscope

- Halogen HPX lamp provides light output for true tissue colour and performance
- Fibre optics project cool light to the distal tip with no reflections or obstructions for superior views of the tympanic membrane



### Welch Allyn® PanOptic™ Ophthalmoscope

- Fast, easy entry into undilated pupils with 5X larger view of the fundus for a streamlined examination
- 25° field of view vs. the standard 5° field of view provides optimal visualisation



### Welch Allyn® MacroView™ Otolaryngoscope

- Almost twice the field of view and 30% more magnification than other otolaryngoscopes
- Allows for simplified diagnosis of Otitis Media through superior visualisation of the tympanic membrane



**HOP1086** PanOptic Prestige With Panoptic Ophthalmoscope & Diagnostic Macroview Otolaryngoscope

**HOP1086.1** Elite with LED Coaxial Ophthalmoscope & Diagnostic Otolaryngoscope

**HOP024.1** Mobile Stand for Wall Transformer

## Welch Allyn® Green Series™ 777 Wall System

Industry-leading blood pressure and thermometry devices provide you with fast, accurate and reliable patient data you can trust - to help improve patient care and clinical decisions. All configurations are supplied with the following as standard:

- 777 Wall Transformer
- 767 Aneroid Sphygmomanometer
- Speculum Dispenser
- Easy to install pre-drilled mounting board



### Wall Aneroid

- Recessed, laser-engraved dial face with high-contrast pointer provides certified accuracy to reduce errors and improve patient care
- Lifetime calibration warranty on manometer reduces cost of ownership



### SureTemp® Plus Electronic Thermometer

- Provides several, accurate temperatures in a matter of seconds.
- Single-use probe covers for hygiene
- Takes up to 6,000 readings on 3 AA batteries



### Connex® ProBP™ Digital Blood Pressure Device

- Capable of 15-second NIBP readings
- Portable, to take readings anywhere
- Connect to most leading EMR systems, to improve patient documentation



**Baxter**



**HOP1088** Elite PanOptic Prestige Integrated Diagnostic System Panoptic Ophthalmoscope/Professional Otolaryngoscope

**HOP1088.1** Integrated Wall System with Elite Ophthalmoscope, Professional Otolaryngoscope, Specula holder & LED bulbs

**HOP1090** Elite Integrated Diagnostic System Elite Ophthalmoscope/Diagnostic Otolaryngoscope

**HOP1091** Integrated Diagnostic System With Connex® PRO BP/Elite/Macroview & SureTemp Plus Thermometer

**HOP1092** Integrated Diagnostic System With Connex® PRO BP/Panoptic/Macroview & SureTemp Plus Thermometer

## Welch Allyn® SureColor™ LED Bulbs

Do you ever find yourself wondering where that spare bulb has gone? – If you use LED Technology, you won't need to look.

- Long life removes inconvenient interruptions for bulb changes
- 7-year warranty ensures peace of mind
- LED uses less energy - lower contact temperature and costs
- Extend your rechargeable handle battery life by x 3
- Patented circuitry preserves the feel of halogen while offering the efficient performance of LED technology
- SureColor™ LED technology enables a reduction of intensity to alleviate patient glare while preserving the colour and clarity

<b>HOP643</b>	Otoscope LED Replacement Bulb (03100-LED)
<b>HOP644</b>	MacroView LED Replacement Bulb (6500-LED)
<b>HOP645</b>	Ophthalmoscope LED Replacement Bulb (04900-LED)
<b>HOP646</b>	PanOptic™ Ophthalmoscope LED Bulb (03800-LED)



**Baxter**

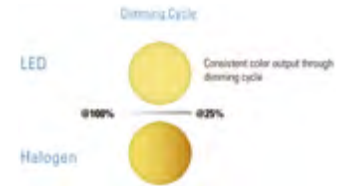

## Welch Allyn® SureColor™ LED Bulbs

A range of replacement bulbs to fit Welch Allyn Ophthalmoscopes and Otoscopies.

<b>HOP014</b>	Halogen HPX Replacement Bulb (04900-U)
<b>HOP016</b>	Halogen Replacement Bulb (03100-U)
<b>HOP017</b>	PocketScope Otoscope Halogen Bulb (03400-U)
<b>HOP018</b>	PocketScope Ophthalmoscope Halogen Bulb (03900-U)
<b>HOP235.1</b>	PanOptic Ophthalmoscope Halogen HPX Bulb (03800-LED)
<b>HOP476</b>	MacroView Halogen Replacement Bulb (06500-U)
<b>HOP742</b>	Halogen Ophthalmoscope Replacement Bulb (03000-U)



## Welch Allyn® Power Sources



**HOP027**



**HOP231**



**HOP510**

<b>HOP027</b>	3.5v Li-Ion Diagnostic Handle & Charger (Handle Shown)
<b>HOP510</b>	3.5v NiCad Battery (72200) for desk charger
<b>HOP231</b>	3.5v NiCad Battery (72300)

## Welch Allyn® Specula & Accessories



<b>HOP011</b>	Disposable Welch Allyn® Otoscope Specula 2.75mm (850)
<b>HOP012</b>	Disposable Welch Allyn® Otoscope Specula 4.25mm (850)
<b>HOP013</b>	Autoclavable Reusable Welch Allyn® Otoscope Specula (x4)
<b>HOP477</b>	Insufflator Bulb for Welch Allyn® MacroView
<b>HOP478</b>	Throat illuminator section for Welch Allyn® MacroView

# LED IN HEINE QUALITY – LED<sup>HQ</sup> THE NEW STANDARD IN LED ILLUMINATION

LED in HEINE Quality – 5 advantages that set a new standard in LED Illumination. With our many years of R&D experience in LED-Technologies, our engineers focused on 5 key elements in the development of new LED-Technologies. Every HEINE LED instrument must fulfil the requirements of each of these key elements to meet the HEINE Standard.



## LIGHT INTENSITY

Light intensity is measured in Lux, at the defined working distance of the instrument. Each HEINE LED instrument has been engineered to provide the optimal illumination that is ideally suited for the application. Depending on the application, the LED either is preset to the optimum brightness or can be continuously adjusted in light intensity.



## THERMAL MANAGEMENT

LEDs will only perform at their optimum level in very specific temperature ranges. Operating outside the specified temperature range will affect brightness, colour temperature as well as result in reduction in lifetime and reliable performance over time. Instrument design and special materials such as ceramics, heat conducting foils, heat dissipating bonding materials and aluminum heat sinks are utilised to ensure that the LEDs always operate at the ideal temperature, ensuring consistent performance and a long life.



## HOMOGENEITY

The HEINE LEDs have been synchronized with the HEINE precision optical systems in each instrument to ensure an absolutely homogeneous distribution of light across the entire field of view, including the edges. The result is high contrast, distortion free images with no distracting reflexes, shadows, or disturbing 'hot-spots'.

## LONG LIFE

## DURABILITY

High quality LEDs that are tailored to and properly integrated into the operating environment have a virtually unlimited working life. HEINE LED instruments are virtually maintenance free, with no need to ever exchange the LED. In addition, the high efficiency of LEDs and low power consumption means extended use times and longer battery life.

**CRI  
90**

## COLOUR RENDERING

The CRI (Colour Rendering Index) indicates how exactly colours are reproduced in comparison with daylight. The closer this number is to a maximum of 100, the more accurate the lighting system is, meaning that colours are displayed in their natural state. Red is red. Blue is blue. HEINE LED instruments have exceptionally high CRI values to ensure the examiner sees the colours as they are, for the most reliable and accurate diagnosis.



LED NOW IN HEINE QUALITY.

## HEINE® BETA® 400 Fibre Optic Oscope

The most advanced high quality otoscope making more details visible, while maintaining familiar handling and functionality. With a magnification factor of 4.2x and multi-coated precision optics for sharp spatial images, it provides for the best diagnosis.

Combined with a large field of view the ear canal and tympanum are clearly visible at a glance. The unique opening mechanism can be operated with one hand and flips up the optical system.

- **4.2x Magnification unrivalled:** More detail of anatomical structures and easy recognition of foreign bodies.
- **Exceptional Depth of Field:** Precise image: Provides sharp spatial images in a convenient working range.
- **One Hand Operation:** Optical system to be flipped open, enabling instrumentation and ease of cleaning.

**HOP1300** XHL Oscope without handle 2.5V

**HOP1301** XHL Oscope without handle 3.5V

**HOP1300.1** LED Oscope without handle



**HOP1371** 2.5V XHL Set – BETA Battery handle

**HOP1372** 3.5V XHL Set – BETA4 USB Recharge handle, Plug-in Power

**HOP1374** 3.5V XHL Set – BETA4 NT Recharge handle & NT4 charger

**HOP1375** LED Set – BETA4 USB recharge handle, Plug-in Power

**HOP1377** LED Set – BETA4 NT Recharge handle & NT4 charger

## HEINE® BETA® 200 Diagnostic Set

Exclusive dustproof design protects the precision optical components and ensures maintenance-free operation. The BETA 200 diagnostic sets are the only instruments with an aluminium frame system.

Optical components are flush-mounted on a cast aluminum frame, eliminating misalignment and making the instrument shock-resistant.

- LED in HQ: The new standard in LED illumination defining optimal light intensity, homogeneity and colour rendering for the most accurate diagnosis.
- Red is red, blue is blue. Colour temperature: 3,500 K, Colour Rendering Index (CRI) > 97, exceptional colour rendering
- BETA200 Otoscope with 3 x magnification. The multi-coated glass viewing window offers high resolution images
- Exclusive continuous brightness control between 100% and 3% (patented) with one-finger operation.
- BETA200 Ophthalmoscope with lenses from -35D to +40D

### Set complete with:

- BETA 200 Ophthalmoscope / BETA 200 F.O. Otoscope both with XHL or LED
- 1x Set of 4 reusable tips and spare bulb each for XHL version
- 5x All Spec disposable tips 2.5mm and 4 mm Ø
- Easy to clean hard case

**HOP374** Spare Bulb for BETA 200 2.5v Fibre Optic Otoscope

**HOP375** Spare Halogen Bulb for BETA 200 3.5v Ophthalmoscope

**HOP375.1** Spare Bulb for BETA 200 3.5v Fibre Optic Otoscope



**HOP1361** 2.5V XHL Set with Battery Handle

**HOP1362** 3.5V XHL Set with USB charge handle & Power supply

**HOP1364** 3.5V XHL with charge handle and NT 4 table charger

**HOP1365** LED Set with USB charge handle & Power supply

**HOP1367** LED with charge handle and NT 4 table charger

**HOP384** Disposable 4.0mm Specula - 100pk

**HOP386** Disposable 2.5mm Specula - 100pk

**HOP382** Set of 4 Reusable Specula - 2.4 / 3.0 / 4.0 / 5.0mm

## HEINE® K180 Diagnostic Set

**A full-featured instrument at an economical price.**

Otoscope with Fiber Optic illumination constructed of light, high-impact polycarbonate. Fiber Optic Illumination. Ensures homogeneous, very bright illumination and an unobstructed view of the ear canal and tympanum.

- Precision spherical HEINE optics. Corneal and iris reflexes are eliminated.
- XHL Xenon Halogen Technology. Bright, white light. Clear retinal image.
- Range of lenses: 27 lenses from -35 D to +40 D. Brilliant image even at high corrections.
- Ergonomical shape. The instrument fits the orbita comfortably.
- Soft orbital rest. Steadies the instrument and protects your glasses.
- Choice of 5 apertures. For both large and small pupils. Choice of fixation star or cobalt blue filter for corneal examination.
- Dust resistant housing. Maintenance-free.
- High-impact polycarbonate housing for durability.

**HOP384** Disposable 4.0mm Specula - 100pk

**HOP386** Disposable 2.5mm Specula - 100pk

**HOP382** Set of 4 Reusable Specula - 2.4 / 3.0 / 4.0 / 5.0mm

**HOP368** Spare Bulb for K180 2.5v Fibre Optic Otoscope

**HOP370** Spare Bulb for K180 2.5v Ophthalmoscope

**HOP369** Spare Bulb for K180 3.5v Fibre Optic Otoscope



**HOP350** 2.5v Set with 1 Battery Handle in Hard Case

**HOP352** 3.5V Set with BETA 4 with USB charge handle & Power supply

**HOP354** 3.5V Set with BETA 4 charge handle and NT 4 table charger

## HEINE® BETA® 200 FO Otoroscope

Heine Beta 200 Otoroscope is the ultimate in performance and quality. With solid, all-metal construction with fibre optic (F.O.) illumination.

- Brass casing for strength, with Matt chrome finish
- Smart and practical design
- 3 x magnification viewing window, air tight
- Pneumatic testing adaptor
- 2.5V standard N battery handle
- Supplied complete in case with, re-usable and disposable speculae



**HOP1065** Beta 200 Fibre Optic Otoroscope Set 2.5v

## HEINE® BETA® 200 LED Otoroscope

The otoroscope has been designed with an all metal housing and a scratch resistant glass window which guarantees a lifetime of maintenance-free use.

- 3x magnification. The multi-coated glass viewing window offers high resolution and distortion-free images.
- Fiber Optic Illumination ensures homogeneous, vbright illumination and an unobstructed view of the ear canal.
- LED in HQ: LED illumination defining optimal light intensity, homogeneity and colour rendering
- Colour temperature: typ. 3,500 K, Colour Rendering Index (CRI) > 97, exceptional colour rendering
- Special optical interface to precisely integrate the LED illumination with the optical system to ensure bright (typ. 77,000 lux with tip), homogeneous light during examinations.
- Exclusive continuous brightness control between 100 % - 3 %



**HOP1396** LED F.O. Otoroscope with 4 reuseable tips

**HOP1397** LED F.O. Otoroscope

## HEINE® mini 3000® Otoroscope

- Very bright Xenon illumination
- Swivelling window rotates from viewing aperture
- Swivelling window cannot be lost
- 3x magnification
- Integral pocket on/off switch
- Durable and very reliable
- Disposable tips minimise cross infection
- Uses 2 x AA batteries



**HOP1058** D.I. Otoroscope with Case, 10 Disposable & 4 Reusable tips

**HOP1059** F.O. Otoroscope with Case, 10 Disposable & 4 Reuseable tips

**HOP716** Spare Bulb for mini 3000 Direct Illumination Otoroscope

**HOP717** Spare Bulb for mini 3000 Fibre Optic Otoroscope

**HOP384** Disposable 4.0mm Specula - 100pk

**HOP386** Disposable 2.5mm Specula - 100pk

**HOP722** Set of 4 reusable tips, 2.4/3.0/4.0/5.0mm diameters

## HEINE® mini 3000® Combi Diagnostic Set

- 20,000 On/Off switch cycles guaranteed.
- Reflex-free illumination of tympanum and ear canal.
- Viewing window with 3x magnification and swivel view built in.
- Pneumatic testing of the tympanum mobility.
- mini 3000 Ophthalmoscope head with 5 apertures
- mini 3000 Fibre Optic or Direct Illumination Otoroscope
- Reusable and Disposable Otoroscope tips included

**Choice of 'Black / Blue' with chrome. Specify when ordering**



**HOP491** Combi Set with FO otoroscope - 2 Handles

**HOP712** Combi Set with DI otoroscope - 2 Handles

**HOP1296** mini NT Charger Set for 2 mini 3000 Handles

**HOP384** Disposable 4.0mm Specula - 100pk

**HOP386** Disposable 2.5mm Specula - 100pk

**HOP382** Set of 4 Reusable Specula - 2.4 / 3.0 / 4.0 / 5.0mm

**HOP715** Spare Bulb for mini 3000 Ophthalmoscope

**HOP716** Spare Bulb for mini 3000 Direct Illumination Otoroscope

**HOP717** Spare Bulb for mini 3000 Fibre Optic Otoroscope

## HEINE® mini 3000® LED Diagnostics

Otoscope with fiber Optic and viewing window with 3x magnification, LED illumination, continuous brightness control and a swivelling viewing window.

Ophthalmoscope with 5 different apertures and 18 lenses from -20D to +20D, guaranteed to be dust free, excellent optics and best colour rendering in minimum dimensions

- LED Thermal management for a consistent light output.
- LED in HQ: The new standard in LED illumination defining optimal light intensity, homogeneity and colour rendering for the most accurate diagnosis. Red is red, blue is blue. Colour temperature: typ. 4,000 K, Colour Rendering Index (CRI) > 95, exceptional colour rendering.
- Exclusive Battery Performance Indicator: When switched on, the maximum light intensity is shown.
- Exclusive fade-out function reduces light intensity with battery level letting you know when to Replace/Charge.
- The batteries need to be changed less often and the rechargeable batteries last longer.

**HOP1279** Otoscope with Battery handle, Reuse/Dispos. Tips and Batteries

**HOP1280** Otoscope with Battery handle, Dispos. Tips and Batteries

**HOP1281** Otoscope with Battery handle and Dips. Tips

**HOP1282** Otoscope Head without handle or accessories

**HOP1287** LED Ophthalmoscope Set

mini 3000 LED Ophthalmoscope, mini 3000 battery handle with batteries and hard protective carry case also included.

**HOP1289** LED Diagnostic Battery Set

mini 3000 LED Ophthalmoscope, mini 3000 LED F.O. Otoscope, 4 pcs. reusable tips, 5 of both 2.5 and 4mm dia. AllSpec disposable tips, mini 3000 handle & batteries, hard case.

## HEINE® mini 3000® Ophthalmoscope

- Outstanding optics provide crisp retinal detail
- -20 to +20 with 18 lenses
- 5 apertures for a full diagnostic capability
- Large spot, small spot, fixation star for eccentric fixation
- Hemispot for small pupils, red free filter



**HOP1073** Ophthalmoscope with Hard case



**HOP1283** Insufflation port connector for mini 3000 F.O. Oscopes

**HOP1284** Ophthalmoscope with Battery Handle and Batteries

**HOP1285** Ophthalmoscope with Recharge handle

**HOP1286** Ophthalmoscope without handle

**HOP1288** LED Otoscope Set

mini 3000 LED F.O. Otoscope, 4 pcs. reusable tips, 5 each of 2.5 and 4mm dia. AllSpec disposable tips, mini 3000 battery handle & batteries, hard case.

**HOP1290** LED Diagnostic Rechargeable Set

mini 3000 LED Ophthalmoscope, mini 3000, LED F.O. Otoscope, mini NT table charger, 2 mini 3000 rechargeable handles, 5 of both 2.5 and 4mm dia. AllSpec disposable tips.

## HEINE® mini NT Table Charger

- Two independent charging compartments. Complete functionality for one or two handles at a time
- Fast charge feature. 4 hours to recharge a mini 3000
- Automatic charging and cannot be overcharged
- Charge status display. Light pulses from the charging compartment to confirm the charging mode



**HOP1291** mini NT Charger, only

**HOP1292** mini 3000 Rechargeable handle complete

**HOP1293** Rechargeable battery NiMH 2Z, only

**HOP1294** Bottom insert for mini 3000 Rechargeable Handle, only

**HOP1295** mini NT Adaptor Set for 1 mini 2000 Handle

**HOP1296** mini NT Charger Set for 2 mini 3000 Handles

## HEINE® BETA® 200/400 Diagnostic Sets

### Set includes:

- BETA 200 Ophthalmoscope
- Choice of BETA 200/400 as Fibre Optic/LED Otoscope
- 1 set (4 pcs.) of reusable tips
- 5 of both AllSpec disposable tips 2.5 and 4 mm Ø
- 2 x BETA 4 NT rechargeable handle
- with NT 4 table charger



**HOP1402** Set with BETA400 F.O. Otoscope XHL, 2 Handles & Table Charger

**HOP1403** Set with BETA400 LED Otoscope, 2 Handles & Table Charger

**HOP1404** Set with BETA200 F.O. Otoscope XHL, 2 Handles & Table Charger

**HOP1405** Set with BETA200 LED Otoscope, 2 Handles & Table Charger



## HEINE® BETA 200S Ophthalmoscope

The BETA 200S Ophthalmoscopes are the only instruments with an aluminium frame system. Optical components are flush-mounted on a cast aluminium frame, eliminating misalignment and making the instrument shock-resistant.

The LED version has virtually unlimited hours of working life (typ. 100,000 hours). No need to ever replace bulbs.

- Exclusive aspherical optical system (AOS)
- LED in HQ: defining optimal light intensity, homogeneity and colour rendering for an accurate diagnosis. Red is red, blue is blue. Colour temperature: 3,500°K. Colour Rendering Index (CRI): > 97, exceptional colour rendering
- Special optical interface to precisely integrate the LED illumination with the optical system to ensure bright, homogeneous light during examinations.
- The BETA 200S accommodates higher refractive errors with 28 single lenses, Rekoss Disc and features a 74 single step design on a non-continuous wheel avoiding extreme diopter jumps.
  - + in 1 D steps: +1 through +38 D
  - in 1 D steps: -1 through -36 D
- Exclusive continuous brightness control between 100% and 3% (patented) with one-finger operation.
- No stray light due to the recessed, multi-coated viewing window which eliminates distractions.
- Suitable for large as well as small or undilated pupils.
- Full functionality of the BETA 200S LED is guaranteed with BETA Rechargeable Handles EN 100 / EN 200 Wall Transformers

**HOP1368** LED Ophthalmoscope without handle

**HOP1369** 2.5V Ophthalmoscope without handle

**HOP1370** 3.5V Ophthalmoscope without handle

## HEINE® K180 Ophthalmoscope

- A full-featured instrument at an economical price
- Precision spherical HEINE optics with an ergonomical shape
- Corneal and iris reflexes are eliminated
- XHL Xenon Halogen Technology. Bright, white light
- Clear retinal image
- Range of lenses: 27 lenses from -35 D to +40 D
- Brilliant image even at high corrections
- The instrument fits the orbita comfortably
- Steadies the instrument and protects your glasses
- Choice of 5 apertures
- For both large and small pupils
- Fixation star or cobalt blue filter for corneal examination
- Dust resistant housing that is maintenance-free
- High-impact polycarbonate housing for durability



**HOP1074** K180 Ophthalmoscope in pouch



## HEINE® EN200 Diagnostic Centre

Everything in its right place, ready to use: No more tiresome searches for instruments, or manual charging necessary.

- Exact light conditions and true colour rendering due to continuous brightness control between 100% and 3%.
- Optimised workflow and energy saving due to Ready to use function. With the HEINE EN 200 the handle switches on and off automatically when taken off or returned to the unit.
- Flat, space-saving housing without any openings (no mechanical switch) allows optimal hygienic reprocessing.
- Anti-theft mechanism, secure instrument heads.
- Connectivity Ready. The device has an USB interface in order to connect modules such as the HEINE EN 200 BP.
- Spiral cord with a length of up to 3.50 m.
- Excellent energy efficiency, with an XHL instrument
- Soft Start Technology prevents current surge in bulbs
- Simultaneous use of handles possible.

<b>HOP1395</b>	Wallboard for device combination - See image
<b>HOP1393</b>	AllSpec Tip Dispenser
<b>HSP1181</b>	Gamma XXL LF - Analogue Sphygmomanometer
<b>HSP1253</b>	Cuff Basket - For Storing blood Pressure Cuffs



<b>HOP1390</b>	EN200 Wall transformer without instrument heads
<b>HOP1392</b>	EN200 with K180 F.O. Otoscope & K180 Ophthalmoscope
<b>HOP1391</b>	EN200 with BETA 400 LED F.O. Otoscope & BETA 200 LED Ophthalmoscope
<b>HOP1411</b>	EN200 with GAMMA XXL, BETA 400 LED F.O. Otoscope & BETA 200 LED Ophthalmoscope
<b>HOP1412</b>	EN200 with GAMMA XXL, BETA 200 LED F.O. Otoscope & BETA 200 LED Ophthalmoscope
<b>HOP1413</b>	EN200 with BETA 400 F.O. Otoscope & BETA 200 Ophthalmoscope
<b>HOP1414</b>	EN200 with BETA 200 F.O. Otoscope & BETA 200 Ophthalmoscope

## HEINE® Disposable Specula

Our range of HEINE Disposable specula for the range of HEINE Oscopes, as well as a specula dispenser.



<b>HOP383</b>	Disposable 4.0mm Specula - 500pk (for mini, mini 3000, alpha and Standard Size FO i.e K180/B200)
<b>HOP384</b>	Disposable 4.0mm Specula - 100pk (for mini, mini 3000, alpha and Standard Size FO i.e K180/B200)

<b>HOP385</b>	Disposable 2.5mm Specula - 500pk (for mini, mini 3000, alpha and Standard Size FO i.e K180/B200)
<b>HOP386</b>	Disposable 2.5mm Specula - 100pk (for mini, mini 3000, alpha and Standard Size FO i.e K180/B200)
<b>HOP388</b>	Disposable 4.0mm Specula - 500pk (for Standard Size DI i.e K100/B100)
<b>HOP389</b>	Disposable 4.0mm Specula - 100pk (for Standard Size DI i.e K100/B100)
<b>HOP390</b>	Disposable 2.5mm Specula - 500pk (for Size DI i.e K100/B100)
<b>HOP391</b>	Disposable 2.5mm Specula - 100pk (for Size DI i.e K100/B100)
<b>HOP736</b>	Wall Mounted Specula Dispenser for both 2.5mm and 4.0mm Holds 2 x tubes of 50

## HEINE® EN200 Diagnostic Centre

A range of accessories available for HEINE products including reusable specula, otoscope & ophthalmoscope bulbs and other accessories.

<b>HOP382</b>	Set of 4 Reusable Specula - 2.4 / 3.0 / 4.0 / 5.0mm (for mini, mini 3000, alpha, Standard FO K180/B200)
---------------	---

### Bulbs:

<b>HOP368</b>	Spare Bulb for K180 2.5v Fibre Optic Otoscope
<b>HOP370</b>	Spare Bulb for K180 2.5v Ophthalmoscope
<b>HOP369</b>	Spare Bulb for K180 3.5v Fibre Optic Otoscope
<b>HOP371</b>	Spare Bulb for K180 3.5v Ophthalmoscope
<b>HOP374</b>	Spare Bulb for BETA 200 2.5v Fibre Optic Otoscope



<b>HOP737</b>	Otoscope Insufflation Bulb
<b>HOP375</b>	Spare Halogen Bulb for BETA 200 3.5v Ophthalmoscope
<b>HOP375.1</b>	Spare Bulb for BETA 200 3.5v Fibre Optic Otoscope
<b>HOP715</b>	Spare Bulb for mini 3000 Ophthalmoscope
<b>HOP716</b>	Spare Bulb for mini 3000 Direct Illumination Otoscope
<b>HOP717</b>	Spare Bulb for mini 3000 Fibre Optic Otoscope

## Keeler Ophthalmoscopes & Otoscopes

A combination of optical perfection, superb ergonomics and versatile feature make Keeler otoscopes and ophthalmoscopes the ideal choice. With curved surfaces and subtle patient side marking, each ophthalmoscope has been designed to fit snugly into the orbital bone ensuring a patient friendly, non threatening instrument. The Otoscopes range from the small and portable pocket to the outstanding top of the range Fibre Optic Otoscope all providing the best possible view.

Manufactured in the UK and built from resilient, lightweight materials, a Keeler instrument will give you many years of trouble free service and withstand the rigours of everyday use. So, whatever your requirement from basic examination to detailed diagnosis, Keeler has the instrument for you.

# Keeler

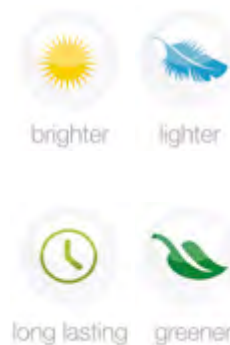

### Keeler Aperture Key



#### Wide Angle

Illuminates the largest area of fundus for the best possible general diagnosis through a dilated pupil.



#### Intermediate

Permits easier access through an undilated pupil and in peripheral examination. Useful in paediatric examination.



#### Macular

Designed to examine the macular region of the fundus where a larger beam would create excessive pupillary reaction or patient discomfort.



#### Slit

Used primarily to determine retinal elevations and depressions but may also be used to assess anterior chamber depth.



#### Glaucoma

Projects a graticule onto the retina to assess the optic cup/disc ratio as an aid to glaucoma diagnosis.



#### Fixation Cross

Projects a graticule onto the retina for assessment of the degree and direction of eccentric fixation.



#### Semi Circle

Provides a combination of depth perception and field of view.



#### Red Free

Used to examine blood vessels in fine detail. By filtering out the red light, blood vessels are silhouetted black.



#### Cobalt Blue

Used in conjunction with fluorescein dye for the detection and examination of corneal scars and abrasions.

### Keeler Jazz Pocket Ophthalmoscope

Our new stylish Jazz Ophthalmoscope will fit in any environment. You can change the colour of your set by adding coloured rings that can suit any mood.

- Brilliant LED illumination
- +/- 20D range of powers
- Renowned high performance Keeler optics with aspherical lens
- 3 Interchangeable Colour Rings

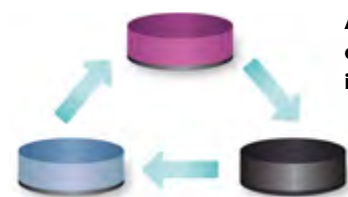

All Jazz instruments are supplied with 3 interchangeable colour rings



- |               |                                   |
|---------------|-----------------------------------|
| <b>HOP681</b> | Jazz Pocket Ophthalmoscope 2.8v   |
| <b>HOP711</b> | 2.8v Bulb for Jazz Ophthalmoscope |
| <b>HCP641</b> | Duracell Ultra MN1500 (AA) - 4pk  |



# Keeler



## Keeler Jazz Fibre Optic Pocket Otoscope

Our new stylish Jazz Otoscope will fit in any environment. You can change the colour of your set by adding coloured rings that can suit any mood.

- Fibre Optic Otoscope
- Brilliant Xenon illumination
- 3x magnifying lens
- 3 Interchangeable Colour Rings



All Jazz instruments are supplied with 3 interchangeable colour rings

<b>HOP680</b>	Jazz Pocket Fibre Optic Otoscope 2.8v
<b>HOP707</b>	Disposable Jazz Otoscope Specula 2.5mm (100)
<b>HOP708</b>	Disposable Jazz Otoscope Specula 3mm (100)
<b>HOP709</b>	Disposable Jazz Otoscope Specula 4mm (100)
<b>HOP710</b>	Disposable Jazz Otoscope Specula 5mm (100)
<b>HCP641</b>	Duracell Ultra MN1500 (AA) - 4pk



Keeler

3 Year Warranty

Keeler

3 Year Warranty



## Keeler Jazz Pocket Diagnostic Set

- Brilliant Xenon illumination
- +/- 20D range of powers
- Renowned performance Keeler optics with aspherical lens
- Fibre Optic Otoscope
- 3 x magnifying lens In a handy pouch with two handles



All Jazz instruments are supplied with 3 interchangeable colour rings



<b>HOP707</b>	Disposable Jazz Otoscope Specula 2.5mm (100)
<b>HOP708</b>	Disposable Jazz Otoscope Specula 3mm (100)
<b>HOP709</b>	Disposable Jazz Otoscope Specula 4mm (100)
<b>HOP710</b>	Disposable Jazz Otoscope Specula 5mm (100)

<b>HOP682</b>	Jazz Pocket Diagnostic Set – Two Handles
<b>HOP711</b>	2.8v Bulb for Jazz Ophthalmoscope
<b>HCP641</b>	Duracell Ultra MN1500 (AA) - 4pk

## Keeler Jazz Pocket Ultra Diagnostic Set

Weighing in at just 89g, less than half the weight of an apple, and measuring just 130mm, the Jazz Ultra really is pocket sized. The 'go anywhere' Jazz Ultra, with its sleek ergonomic design, can be with you where ever you are working.

- Ideal for domiciliary or ward use or as a second instrument
- Full diagnostic capability with 6 diagnostic beams
- Supplied in a hard case with one handle (requires 2 x AA batteries, not supplied), 4x reusable specula, 4x disposable specula, spare otoscope bulb, spare ophthalmoscope bulb & bulb extractor
- Pure white uniform illumination shows colours as they really are for more efficient diagnosis plus a longer life battery
- Sealing precision optics for optimum views every time
- Specula available in 5 sizes: 2mm, 2.5mm, 3mm, 4mm, 5mm



<b>HOP1351</b>	Jazz Pocket Ultra Diagnostic Set 2.8v – Two Handles
----------------	---



Keeler

3 Year Warranty

<b>HOP707</b>	Disposable Jazz Otoscope Specula 2.5mm (100)
<b>HOP708</b>	Disposable Jazz Otoscope Specula 3mm (100)
<b>HOP709</b>	Disposable Jazz Otoscope Specula 4mm (100)
<b>HOP710</b>	Disposable Jazz Otoscope Specula 5mm (100)

## Keeler Standard Ophthalmoscope

- The positive maywheel lens control allows you to click through the lens powers from +40D to -25D.
- This increased lens range allows detailed examination of the ocular structures and provides ease of use for spectacle wearers
- Two diagnostic beams - wide angle beam for general examination. Macular beam for more detailed examination
- Red free filter for enhanced vessel examination can be used with both diagnostic beams, particularly useful for diabetic assessment & monitoring
- Soft integral brow rest allows for easy positioning and protects your lenses if you are a spectacle wearer
- Supplied in hard case with spare bulb

**Keeler**



<b>HOP268.1</b>	Standard LED Ophthalmoscope 2.8V
<b>HOP268</b>	Standard Ophthalmoscope 2.8v
<b>HOP261</b>	Standard / Practitioner Ophthalmoscope Bulbs 2.8v - 2pk
<b>HCP641</b>	Duracell Ultra MN1500 (AA) - 4pk

## Keeler Practitioner Ophthalmoscope

- The positive maywheel lens control allows you to select the lens powers from +40D to -25D.
- This increased lens range allows detailed examination of the ocular structures and provides ease of use for spectacle wearers
- Six beams for full diagnostic capability
- Blue filter - useful for assessing corneal scratches in children
- Red free filter for enhanced vessel examination can be used with diagnostic beams, particularly useful for diabetic assessment & monitoring
- Soft integral brow rest allows for easy positioning and protects your lenses if you are a spectacle wearer
- Supplied in hard case with spare bulb

**Keeler**



<b>HOP282.1</b>	Practitioner LED Ophthalmoscope 2.8V
<b>HOP285.1</b>	Practitioner LED Ophthalmoscope 3.6V
<b>HOP282</b>	Practitioner Ophthalmoscope 2.8v
<b>HOP285</b>	Practitioner Ophthalmoscope 3.6v
<b>HOP261</b>	Standard / Practitioner Ophthalmoscope Bulbs 2.8v - 2pk
<b>HOP291</b>	Standard / Practitioner Ophthalmoscope Bulbs 3.6v - 2pk
<b>HCP641</b>	Duracell Ultra MN1500 (AA) - 4pk

## Keeler Standard Otoscope

The industry standard for ward and GP use. A great Otoscope to take on ward rounds or for GP's to get a quick look. Ideal for domicilliary or ward use or as a second instrument.

- 2.5x magnifying lens, removable to allow the introduction of small instruments
- Closed head design suited to pneumatic testing
- Supplied with 4 disposable specula
- Supplied in hard case with spare bulb, bulb extractor and pneumatic testing adaptor

**Keeler**



<b>HOP267</b>	Standard Otoscope 2.8v
<b>HOP287</b>	Standard Rechargeable Otoscope 3.6v
<b>HOP133</b>	Standard / Deluxe / Pocket Otoscope 2.8v Bulb - 2pk
<b>HOP134</b>	Standard / Deluxe Otoscope 3.6v Bulb - 2pk
<b>HOP259</b>	Mini Lithium Charger for Rechargeable Sets
<b>HCP641</b>	Duracell Ultra MN1500 (AA) - 4pk

## Keeler Practitioner Otoscope

A popular otoscope that tends to be purchased by the GP or Primary Care Specialist. Unobstructed open style head for easy introduction of small instruments for wax/foreign body removal.

- Large slide aside 2.5x lens for clear view of aural structures and procedures under magnification
- Facility to undertake pneumatic testing for tympanic mobility
- Disposable specula supplied
- Supplied in hard case with spare bulb, bulb extractor and pneumatic testing adaptor.

**Keeler**



<b>HOP270</b>	Practitioner Otoscope 2.8v (batteries required)
<b>HOP271</b>	Standard Rechargeable Otoscope 3.6v
<b>HOP135</b>	2.8v Bulb for Practitioner Otoscope - 2pk
<b>HOP136</b>	3.6v Bulb for Practitioner Otoscope - 2pk
<b>HOP259</b>	Mini Lithium Charger for Rechargeable Sets
<b>HCP641</b>	Duracell Ultra MN1500 (AA) - 4pk

## Keeler Fibre Optic Otoscope

Halogen illumination transmitted via optic fibres for homogenous illumination with clear and accurate diagnosis for aural images.

- Closed head ideally suited to pneumatic testing for tympanic mobility
- Large slide aside 2.5x lens for clear view of aural structures and procedures under magnification
- Supplied with 4 reusable and disposable specula
- Supplied in hard case with spare bulb and pneumatic testing adaptor
- 2.8v Version requires 2 x AA batteries (not supplied)  
Charger not included with rechargeable model.

<b>HOP260</b>	Fibre Optic Otoscope 2.8v
<b>HOP284</b>	Fibre Optic Rechargeable Otoscope 3.6v
<b>HOP135</b>	2.8v Bulb for Practitioner Otoscope - 2pk



**Keeler**  
3 Year Warranty

<b>HOP136</b>	3.6v Bulb for Practitioner Otoscope - 2pk
<b>HOP259</b>	Mini Lithium Charger for Rechargeable Sets
<b>HCP641</b>	Duracell Ultra MN1500 (AA) - 4pk



Please Note: LED sets only contain LED in Ophthalmoscope

<b>HOP458.1</b>	Standard LED Diagnostic Set 2.8V
<b>HOP269.1</b>	Standard LED Diagnostic Set 3.6V
<b>HOP458</b>	Standard Diagnostic Set 2.8v
<b>HOP269</b>	Standard Diagnostic Set 3.6v rechargeable
<b>HOP259</b>	Mini Lithium Charger for Rechargeable Sets
<b>HOP139</b>	Permanent Specula - 5pk
<b>HOP133</b>	Standard / Deluxe / Pocket Otoscope 2.8v Bulb - 2pk
<b>HOP134</b>	Standard / Deluxe Otoscope 3.6v Bulb - 2pk

## Keeler Standard Diagnostic Set

- Ideal for domiciliary or ward use or as a second instrument
- 2.5x magnifying lens, removable to allow the introduction of small instruments
- Closed head design suited to pneumatic testing
- Positive mawheel lens control of - +40D to -25D
- Increased lens range allows detailed examination of ocular structures and provides ease of use for spectacle wearers
- Wide angle beam for general examination
- Macular beam for more detailed examination
- Red free filter for enhanced vessel examination can be used with both diagnostic beams, particularly useful for diabetic assessment & monitoring
- **Supplied in a hard case with:**  
One handle, 4 x reusable specula, pneumatic adaptor, spare otoscope bulb, spare ophthalmoscope bulb and bulb extractor.

<b>HOP261</b>	Standard / Practitioner Ophthalmoscope Bulbs 2.8v - 2pk
<b>HOP291</b>	Standard / Practitioner Ophthalmoscope Bulbs 3.6v - 2pk

## Keeler Standard Diagnostic Set with Fibre Optic Otoscope

### Otoscope

- Halogen illumination transmitted via optic fibres for homogenous illumination leading to clear and accurate diagnosis for aural images
- Closed head ideally suited to pneumatic testing for tympanic mobility
- Large slide aside 2.5x lens for clear view of aural structures and procedures under magnification

### Ophthalmoscope

- The positive mawheel lens control allows you to click through the lens powers from +40D to -25D. This increased lens range allows detailed examination of the ocular structures and provides ease of use for spectacle wearers
- Two diagnostic beams - wide angle beam for general examination. Macular beam for more detailed examination
- Red free filter for enhanced vessel examination can be used with both diagnostic beams
- Two diagnostic beams - wide angle beam for general examination. Macular beam for more detailed examination

<b>HOP701.1</b>	Standard Fibre Optic LED Diagnostic Set 2.8v
<b>HOP701</b>	Standard Fibre Optic Diagnostic Set 2.8v

Please Note: LED sets only contain LED in Ophthalmoscope

**Keeler**  
3 Year Warranty



<b>HOP139</b>	Permanent Specula - 5pk
<b>HOP133</b>	Standard / Deluxe / Pocket Otoscope 2.8v Bulb - 2pk
<b>HOP261</b>	Standard / Practitioner Ophthalmoscope Bulbs 2.8v - 2pk

## Keeler Practitioner Diagnostic Set

- Unobstructed open style head for easy introduction of small instruments for wax or foreign body removal
  - Large slide aside 2.5x lens for clear view of aural structures and procedures under magnification
  - Facility to undertake pneumatic testing for tympanic mobility
  - Disposable specula supplied
  - Positive mawheel lens control of - +40D to -25D
  - Increased lens range allows detailed examination of ocular structures and provides ease of use for spectacle wearers
  - Wide angle beam for general examination
  - Macular beam for more detailed examination
  - Red free filter for enhanced vessel examination can be used with both diagnostic beams, particularly useful for diabetic assessment & monitoring
- **Supplied with:**  
Hard carry case, one handle, spare bulb, bulb extractor and pneumatic testing adaptor

<b>HOP272.1</b>	Practitioner LED Diagnostic Set 2.8v
<b>HOP290.1</b>	Practitioner LED Diagnostic Set 3.6v Rechargeable
<b>HOP272</b>	Practitioner Diagnostic Set 2.8v
<b>HOP290</b>	Practitioner Diagnostic Set 3.6v Rechargeable
<b>HOP259</b>	Mini Lithium Charger for Rechargeable Sets
<b>HOP135</b>	2.8v Bulb for Practitioner Otoscope - 2pk
<b>HOP136</b>	3.6v Bulb for Practitioner Otoscope - 2pk
<b>HOP261</b>	Standard / Practitioner Ophthalmoscope Bulbs 2.8v - 2pk
<b>HOP291</b>	Standard / Practitioner Ophthalmoscope Bulbs 3.6v - 2pk



**Keeler**  
3 Year Warranty

**Please Note: LED sets only contain LED in Ophthalmoscope**

<b>HOP139</b>	Permanent Specula - 5pk
<b>HCP641</b>	Duracell Ultra MN1500 AA x4

## Keeler Practitioner Diagnostic Set with Fibre Optic Otoscope

- Halogen illumination transmitted via optic fibres for homogenous illumination for accuracy and clarity
  - Closed head ideally suited to pneumatic testing
  - Large slide aside 2.5x lens for clear view of aural structures and procedures under magnification
  - Positive mawheel lens control of - +40D to -25D
  - Increased lens range allows detailed examination of ocular structures and provides ease of use for spectacle wearers
  - Wide angle beam for general examination
  - Macular beam for more detailed examination
  - Red free filter for enhanced vessel examination can be used with both diagnostic beams, particularly useful for diabetic assessment & monitoring
- **Supplied with:**  
Hard carry case, 4 x reusable & disposable specula, pneumatic adaptor, spare otoscope bulb, spare ophthalmoscope bulb and bulb extractor.

<b>HOP252.1</b>	Practitioner LED Diagnostic Set F/O Otoscope 2.8v
<b>HOP281.1</b>	Practitioner LED Diagnostic Set F/O Otoscope 3.6v
<b>HOP252</b>	Practitioner Diagnostic Set F/O Otoscope 2.8v
<b>HOP281</b>	Practitioner Diagnostic Set F/O Otoscope 3.6v
<b>HOP259</b>	Mini Lithium Charger for Rechargeable Sets
<b>HOP139</b>	Permanent Specula - 5pk
<b>HOP135</b>	2.8v Bulb for Practitioner Otoscope - 2pk
<b>HOP136</b>	3.6v Bulb for Practitioner Otoscope - 2pk
<b>HOP261</b>	Standard / Practitioner Ophthalmoscope Bulbs 2.8v - 2pk
<b>HOP291</b>	Standard / Practitioner Ophthalmoscope Bulbs 3.6v - 2pk
<b>HCP641</b>	Duracell Ultra MN1500 AA x4

**Please Note: LED sets only contain LED in Ophthalmoscope**

**Keeler**  
3 Year Warranty



## Keeler Pocket Diagnostic Set

- Removable 2.5x magnifying lens
- Closed head design suited to pneumatic testing
- Supplied with 4 disposable specula
- Full diagnostic capabilities with 6 Diagnostic Beams



<b>HOP278</b>	Pocket Diagnostic Set
<b>HOP133</b>	Standard / Deluxe / Pocket Otoscope 2.8v Bulb - 2pk
<b>HOP130</b>	2.8v Bulb for Pocket Ophthalmoscope - 2pk C
<b>HOP139</b>	Permanent Specula - 5pk
<b>HCP641</b>	Duracell Ultra MN1500 AA x4

## Keeler Standard Desk Set

- Complete with Lithium Charger & Slim Line Handles
- Ideal for ward, surgery, consulting or casualty rooms & Wall mountable
- 3.6v Illumination
- Standard otoscope and standard ophthalmoscope heads

Please Note: LED sets only contain LED in Ophthalmoscope



<b>HOP456.1</b>	Standard LED Diagnostic Desk Set
<b>HOP456</b>	Standard Diagnostic Desk Set
<b>HOP134</b>	Standard / Deluxe Otoscope 3.6v Bulb - 2pk
<b>HOP291</b>	Standard / Practitioner Ophthalmoscope Bulbs 3.6v - 2pk
<b>HOP139</b>	Permanent Specula - 5pk
<b>HOP143</b>	Disposable Specula for all Otoscopes 3.5mm (500)

## Keeler Practitioner Desk Set

- Complete with Lithium Charger & Slim Line Handles
- 3.6v Illumination
- Wall Mountable
- Practitioner otoscope and ophthalmoscope heads

Please Note: LED sets only contain LED in Ophthalmoscope



<b>HOP454.1</b>	Practitioner LED Diagnostic Desk Set
<b>HOP454</b>	Practitioner Diagnostic Desk Set
<b>HOP136</b>	3.6v Bulb for Practitioner Otoscope - 2pk
<b>HOP291</b>	Standard / Practitioner Ophthalmoscope Bulbs 3.6v - 2pk
<b>HOP139</b>	Permanent Specula - 5pk
<b>HOP143</b>	Disposable Specula for all Otoscopes 3.5mm (500)

## Keeler Practitioner Fibre Optic Desk Set

- Complete with Lithium Charger & Slim Line Handles
- 3.6v Illumination
- Wall Mountable
- Fibre Optic Practitioner otoscope and ophthalmoscope heads

Please Note: LED sets only contain LED in Ophthalmoscope



<b>HOP457.1</b>	Practitioner LED Fibre Optic Diagnostic Desk Set
<b>HOP457</b>	Practitioner Fibre Optic Diagnostic Desk Set
<b>HOP136</b>	3.6v Bulb for Practitioner Otoscope - 2pk
<b>HOP291</b>	Standard / Practitioner Ophthalmoscope Bulbs 3.6v - 2pk
<b>HOP139</b>	Permanent Specula - 5pk
<b>HOP143</b>	Disposable Specula for all Otoscopes 3.5mm (500)

## Keeler Standard Wall Set

Keeler's anti-theft designed diagnostic sets have a lockable head and handle fitting. Keeping them safe and secure.

- Compact modern wall mounted design is ideal for ward, surgery, consulting room and casualty use
- Robust construction suited to the busiest working conditions
- Strong coiled tangle free cable permits instrument use up to 3 metres for transformer position
- Automatic illumination when the instruments are removed from their cradle. With LED confirmation
- Modern design and neutral colour
- Standard otoscope and standard ophthalmoscope

### Wall Sets:

**HOP274** Standard Diagnostic Wall Set - A

**HOP275** Practitioner Wall Set - B

**HOP276** Practitioner Fibre Optic Wall Set - C

### Accessories:

**HOP139** Permanent Specula - 5pk

**HOP143** Disposable Specula for all Otoscopes 3.5mm (500)



## Keeler Roll Stand Mounted Diagnostic Sets

- Compact modern wall mounted design is ideal for ward, surgery, consulting room and casualty use
- Robust construction is ideally suited to busu working conditions
- Strong coiled tangle free cable permits instrument use up to 3 metres for transformer position
- Automatic illumination when the instruments are removed from their cradle. With LED confirmation
- Modern design and neutral colour
- Complete with Dispos-A-Spec Dispenser

### Choice of either:

- Standard otoscope and standard ophthalmoscope
- Fibre Optic otoscope and Practitioner ophthalmoscope heads

**HOP274.1** Roll Stand Mounted Standard Diagnostic Set

**HOP276.1** Roll Stand Mounted Practitioner F/O Diagnostic Set



## Keeler Dispos-A-Spec & Disposable Specula

- The ideal companion for the Keeler Diagnostic Wall Set
- Complete with 25 x 2.5mm, 25 x 3.5mm, 4.5mm and 5.5mm disposable specula
- Easy removeable lid for inserting replacement specula
- Modern, robust design matches Keeler wall set
- Disposable reduces risk of cross infection

**HOP292** Dispos-A-Spec wall mounted ear specula dispenser

### Disposable Specula:

**HOP293** Disposable Specula for all Otoscopes 2.5mm (500)

**HOP143** Disposable Specula for all Otoscopes 3.5mm (500)

**HOP294** Disposable Specula for all Otoscopes 4.5mm (500)

**HOP144** Disposable Specula for all Otoscopes 5.5mm (500)



**HOP707** Disposable Jazz Otoscope Specula 2.5mm (100)

**HOP708** Disposable Jazz Otoscope Specula 3mm (100)

**HOP709** Disposable Jazz Otoscope Specula 4mm (100)

**HOP710** Disposable Jazz Otoscope Specula 5mm (100)



## Keeler Bulbs

- All Keeler instruments use genuine Halogen and Xenon technology, yielding a brighter, whiter illumination and a longer life.
- Look at the bottom of your bulb to identify if your instrument is 2.8V (Dry cell) or 3.6V (Rechargeable).



2.8V (Dry cell)

3.6V (Rechargeable)

Keeler



### Ophthalmoscope Bulbs:

<b>HOP130</b>	2.8v Bulb for Pocket Ophthalmoscope - 2pk C
<b>HOP711</b>	2.8v Bulb for Jazz Ophthalmoscope
<b>HOP131</b>	Vista 2.8v Bulbs for Ophthalmoscope - 2pk A
<b>HOP132</b>	Vista 3.6v Bulbs for Ophthalmoscope - 2pk A
<b>HOP261</b>	Standard / Practitioner Ophthalmoscope Bulbs 2.8v - 2pk
<b>HOP291</b>	Standard / Practitioner Ophthalmoscope Bulbs 3.6v - 2pk

### Otoscope Bulbs:

<b>HOP133</b>	Standard / Deluxe / Pocket Otoscope 2.8v Bulb - 2pk
<b>HOP134</b>	Standard / Deluxe Otoscope 3.6v Bulb - 2pk
<b>HOP135</b>	2.8v Bulb for Practitioner Otoscope - 2pk
<b>HOP136</b>	3.6v Bulb for Practitioner Otoscope - 2pk

## Keeler Power Sources

### Mini Lithium Charger

The Lithium-ion Mini charger can be connected quickly and simply to the base of your Keeler handle, making it the perfect choice for domiciliary visits or practitioners on the move.

- Fast charge in 2 hours
- Provides over 2 hours of continuous use
- Can use instrument whilst charging battery
- LEDs indicate when battery life is low, charging or fully charged



HOP259

Keeler



HOP259.1

### Double Charger

The compact charger takes two handles and fits neatly into your immediate testing environment, allowing easy access to your hand-held instruments. It can be table top or wall mounted.

- Fast charge in 2 hours
- Provides over 2 hours of continuous use
- LEDs indicate when battery life is low, charging or fully charged



HOP286

<b>HOP508</b>	Wall Mounting Kit
<b>HCP641</b>	Duracell Ultra MN1500 AA x4

<b>HOP259</b>	Mini Lithium Charger for Rechargeable Sets
<b>HOP286</b>	Double Charger
<b>HOP259.1</b>	Lithium Battery 3.6v

## Keeler Accessories

A range of accessories suitable for Keeler ophthalmoscopes and otoscopes

Keeler



<b>HOP139</b>	Permanent Specula - 5pk
<b>HOP146</b>	Bulb Extractor for all Keeler
<b>HOP150</b>	Airtight Chamber/Magnifier for Standard/FO & Pocket

<b>HOP151</b>	Pneumatic Testing/Insufflator Bulb for all Otoscopes
<b>HOP293</b>	Disposable Specula for all Otoscopes 2.5mm (500)
<b>HOP294</b>	Disposable Specula for all Otoscopes 4.5mm (500)

## Riester e-scope®

### e-scope® Fibre Optic LED Otoscope

- Alkaline batteries, 50 hours of use
- Service life time of LED of 20,000
- Unique LED technology 3.7V LED illumination (5,500 Kelvin)
- Sealing precision optics pivotable to both sides
- Suitable for performance of pneumatic tests (supplied without connector and insufflator)

### e-scope® LED Ophthalmoscope (Available in black or white)

- 3.7V LED Ophthalmoscope
- Dioptre disc with 18 corrective lenses (+/- 1, 2, 3, 4, 6, 8, 10, 15, 20 dioptres)
- Easy-to-use aperture wheel with six different apertures (fixation star, large and small circle, red free, blue, semi circle)
- High performance optics with aspherical condenser lens
- Spectacle protection & dust-protected



**HOP683** Fibre Optic LED Otoscope

**HOP684** LED Ophthalmoscope (Choice of Black or White)

**HOP685** LED Set (Otoscope & Ophthalmoscope in a case)

## Riester EliteVue oto-/ophthal

Offers a significantly improved view of the auditory canal and tympanic membrane, enabling more efficient diagnosis and enhanced patient outcomes. Suitable for throat illumination.

- High-performance LED illumination (4,000 Kelvin, CRI = 92)
- More than 5-fold magnification & Twice the field of view
- Complete view of the tympanic membrane
- Reflection-optimized high performance glass optics
- Wheel to adjust focal depth
- Easy to operate SpecEjec specula ejection device at the rear side of the otoscope to avoid contamination
- Suitable for pneumatic otoscopy (supplied without ball)



**HOP1417** Oto/ophthal set L2, LED, 2.5V & C-handle (Requires 2x Alkaline)

**HOP1418** Oto/ophthal set L2, LED, 3.5V & C-handle (Requires Li-ion Battery)

**HOP1420** Otoscope set, LED, 2.5V & C-handle (Requires 2x Alkaline)

**HOP1421** Otoscope set, LED, 3.5V & C-handle (Requires Li-ion Battery)

**HOP1419** Recharger (phone type) and battery



### ri-Standard Otoscope Inexpensive Fibre Optic model

- 2.5V halogen Fibre optics for optimal light transmission
- Bi-directional swivelling, sealing optical glass with 3x magnification
- Optional operation lens with 4x magnification available
- Metal fitting for ri-mini® / pen-scope® specula
- Suitable for pneumatic tests (supplied without ball)



### ri-standard L2 Ophthalmoscope 3.5V HL Xenon Illumination

- Diopter wheel with 29 corrective lenses Plus: 1-10, 12, 15, 20, 40 Minus: 1-10, 15, 20, 25, 30, 35
- Easy-to-operate aperture hand-wheel: semi-circle, small/medium/large circle, fixation star, and slit apertures
- Includes filter wheel for all apertures: symbol display, red-free, blue and polarization filters
- High-performance optics with aspherical condenser lens
- Parallel beam path whilst completely dust-proof

**HOP543** Otoscope 2.5V XL, C-Cell Handle (Requires 2x Alkaline)

**HOP551** Ophthalmoscope 3.5V XL on C-Cell Size Handle

**HOP557** 3.5V Diagnostic Set for ri-accu

## Riester ri-standard Instruments

High quality ri-Standard Instruments from Riester, providing a combination of bright illumination and long-lasting power.

The optics are designed to deliver high performance with minimal reflection using optical quality glass and aspherical lenses.

### Diagnostic Set Includes:

- 1x ri-Standard Otoscope Head
- 1x ri-Standard Ophthalmoscope Head
- 1x C-cell Handle
- Durable Li-ion Batteries
- Protective Carry Case



### Desk Set Includes:

- 1x ri-Standard Otoscope Head
- 1x ri-Standard Ophthalmoscope Head
- 2x C-cell Handles
- ri-Charger L for two handles



**HOP562** Complete Desk Set with ri-accu Lithium Charger

**HOP547** Riester ri-charger L for 2 Handles

**HOP548** Riester ri-accu L 3.5V Lithium Rechargeable Battery

## Riester ri-standard Instruments

Premium ri-scope LED Instruments from Riester, The new LED / Li-ion technology results in more reliable instruments due to significantly longer service life of batteries and LEDs.

Nearly unlimited lifetime with the highest luminosity: these advantages make the LED technology and ri-scope unique.

### Diagnostic Set Includes:

- 1x ri-scope LED Otoscope Head
- 1x ri-scope LED Ophthalmoscope Head
- 1x C-cell Handle
- Durable Li-ion Batteries
- Protective Carry Case



### Desk Set Includes:

- 1x ri-scope LED Otoscope Head
- 1x ri-scope LED Ophthalmoscope Head
- 2x C-cell Handles
- ri-Charger L for two handles



**HOP545** Otoscope 3.5V LED & C-Cell Handle (Requires Li-ion Battery)

**HOP553** Ophthal. 3.5V LED & C-Cell Handle (Requires Li-ion Battery)

**HOP563** Desk Set with ri-accu Lithium Charger (Includes Li-ion Battery)



### ri-scope LED Advanced Otoscope

- Fibre optics for optimal beam and light transmission
- Bi-directional swivelling, sealing optical glass with 3x magnification
- Optional operation lens with 4x magnification available
- Metal fitting for ri-mini® / pen-scope® specula
- Suitable for pneumatic tests (supplied without ball)
- More efficient diagnosis by natural, bright LED illumination
- Requires rechargeable battery & charger



### ri-scope LED Advanced Ophthalmoscope

- Corrective lenses for 89 diopter values: Plus 1-45 in single steps Minus 1-44 in single steps
- Easy-to-operate aperture hand-wheel: semi-circle, small/medium/large circle, fixation star, slit and grid apertures
- Includes filter wheel for all apertures: symbol display, red-free, blue and polarization filters
- Focusing device with zero retention force for the correction of ametropias
- Parallel beam path whilst completely dust-proof
- Brilliant powerful natural LED for a better diagnosis
- Requires rechargeable battery & charger

**HOP563.1** Complete Diagnostic Set

**HOP547** Riester ri-charger L for 2 Handles

**HOP548** Riester ri-accu L 3.5V Lithium Rechargeable Battery

## Riester RCS-100 Wireless Camera System

A portable and versatile digital diagnostic camera. Featuring multiple lens attachments, enabling instant sharing across your practice and across the world. This WiFi enabled camera with a 5" screen delivers high-resolution (3264 x 2448) images to accurately document and monitor conditions.

- Rotary wheel for one-hand operation
- Digital camera allows accurate first diagnosis and planning of consistent follow-up treatment
- Easy to use touch screen
- Multi functional diagnosis designed for ENT, dermatology endoscopy and general practice
- Simple lense connections makes changing fast and easy
- 5" full HD color TFT-LCD display 1.280 x 720 pixel including scratch proof cover LCD screen
- 8 MP CMOS delivers high resolution, scaleable images
- Automatic (oto/general lens) & manual (all) focus settings
- Choice of 4° or 9° Endoscope Adapters



**HOP1426** RCS-100 Basic model with no lenses

**HOP1426.1** RCS-100 with otoscope lens

**HOP1426.2** RCS-100 with dermatoscope lens

**HOP1426.3** RCS-100 with general lens

**HOP1426.4** RCS-100 with all lenses (otoscope, dermatoscope & general)

**HOP1426.5** RCS-100 with dermatoscope and general lens

**HOP1426.6** RCS-100 with general and otoscope lens

**HOP1426.7** RCS-100 with dermatoscope and otoscope lens

**HOP1426.8** 4° endoscope lens for RCS-100

**HOP1426.9** 9° endoscope lens for RCS-100

## Riester ri-former Mobile Diagnostic Station

The modular diagnostic station, offers optimal flexibility for medical environments. Can be combined individually to suit each individuals requirements and/or location.

### All your instruments in one place:

- Available with L1, L2 or L3 range of instruments
- Non-slip, ergonomically designed handles with rheostat: the handle enables continuously adjustable brightness as well as manual switching on and off
- Spiral cord stretches up to 3m
- Easy cleaning and disinfection of the instruments
- Maintenance free High-performance LED technology, colour temperature 4.000 K, CRI >90

<b>HOP564</b>	Premium Diagnostic Wall Station with LED Heads
<b>HOP565</b>	Standard Diagnostic Wall Station with Xenon Heads
<b>HOP565.1</b>	Extension module: Big Ben with Adult velcro cuff
<b>HOP1345</b>	Mobile Station with 2 handles, ri-spec, 3.5V/230 V, L2 FO LED otoscope, L2 Ophthalmoscope
<b>HOP1346</b>	Mobile Station with 2 handles, ri-spec, 3.5V/230 V, L2 FO LED otoscope, L2 Ophthalmoscope & Big Ben

HOP1346



HOP1345



HOP564



**Riester**

## Riester ri-former Extension Modules

### Big Ben Square Sphyg

- Large scale with 145.5mm long sides. High-contrast layout guarantees optimum readability
- With extra sturdy wall mounting made of glass-fibre reinforced plastic & extremely sturdy casing
- Maximum error tolerance: +/- 2mm Hg
- Also available as latex-free version (when ordering please indicate LF for 'latex-free' before the article number)
- Supplied with spacious basket for storage of tubes and cuffs, as well as wall mounting plate, plugs and screws
- Individual basket assembly option due to expandable cord



### ri-spec Ear Specula Dispenser

- Specula dispenser with 5 tubes for up to 5 specula sizes
- Hygienic and practical solution, dispenses a new speculum for each examination
- Simple to clean and disinfect
- Easy to refill and can be closed over with a cover
- Filling level of specula tubes can be seen through front
- Suitable for all Riester specula - except uni@/econom@ with metal attachment
- Complete with plugs and screws



<b>HSP031</b>	Riester Big Ben - Wall (Square)
<b>HOP296</b>	ri-spec Ear Specula Dispenser (without specula)
<b>HOP296.1</b>	ri-spec Ear Specula Dispenser with L3 Specula
<b>HOP296.2</b>	ri-spec Ear Specula Dispenser with L1/L2 Specula
<b>HEL217</b>	ri-Thermo N with Anti-Theft Security
<b>HOP640</b>	Tongue Blade Holder 3.5V HP LED Head with Anti-Theft
<b>HOP641</b>	Nasal Speculum 3.5V HP LED Head with Anti-Theft
<b>HOP642</b>	ri-former Extension with Handle (for HOP640/HOP641)

### Tongue Blade Holder

- 3.5V HP LED lamp
- High quality fibre-optic light wave conductor for optimum beam and transmission of light. With the lamp this provides cool light similar to daylight
- Slide attachment for fixing and detaching wooden tongue depressors for a firm hold
- Bayonet fitting for fast and secure attachment to the handle
- Sturdy, light casing made of ABS plastic
- Simple swap of lamp at base of head



### Nasal Speculum

- 3.5V HP LED lamp
- High quality fibre-optic light wave conductor for optimum beam and transmission of light. With the lamp this provides cool light similar to daylight
- Swivel/removable lens with 2.5x mag.
- Bayonet fitting for fast and secure attachment to the handle
- Impact resistant casing made of glass-fibre reinforced plastic
- Simple swap of lamp at base of head



### ri-thermo N

- Precise 'in ear' temperature measurement
- Clinical validation
- Measurement takes approx. 1-2 seconds
- Digital display for optimum readability of the measurement values in °C or in °F
- Memory function for 12 measurements



<b>HEL217.1</b>	Riester Disposable Probe Covers - 25pk
<b>HEL217.2</b>	Riester Disposable Probe Covers - 100pk
<b>HEL217.3</b>	Riester Disposable Probe Covers - 1000pk

## Riester e-xam Diagnostic Pen Light



- Photo-biologically validated according to EN62471:2008
- Available with LED and XL illumination
- LED life span at least 20.000 hrs
- Low maintenance cost thanks to long LED and battery service lives
- Pre-focused an even field of light
- Natural high-performance lighting (180.000 Lux maximum)
- Blade holder, batteries and nylon zipper case included
- Designed for durability
- 2 year warranty including LED



**HOP1347** Black XL - 2.5V

**HOP1348** White XL - 2.5V

**HOP1349** Black LED - 2.5V

**HOP1350** White LED - 2.5V

## Riester Specula



### Reusable ear specula for ri-scope® L1/L2, ri-mini®, e-scope and pen-scope® otoscopes – Packs of 10:

- Selection of sizes: 2–5mm
- Made of black plastic
- Sterilization at 134° C for 10 minutes in steam
- Delivered in a poly bag

**HOP596** Riester Reusable Ear Specula Black - 2mm - 10pk

**HOP597** Riester Reusable Ear Specula Black - 2.5mm - 10pk

**HOP598** Riester Reusable Ear Specula Black - 3mm - 10pk

**HOP599** Riester Reusable Ear Specula Black - 4mm - 10pk

**HOP601** Riester Reusable Ear Specula Black - 5mm - 10pk

### Reusable specula for ri-scope® L3 otoscope– Packs of 10:

- Specially developed for use with the SpecEjec option, absolutely reliable handling
- The 9mm speculum is suitable for use as a nasal speculum
- Selection of different sizes: 2–9mm
- Sterilization at 134° C for 10 minutes in steam sterilizer

**HOP602** Riester Reusable Ear Specula Black - 2mm - 10pk

**HOP603** Riester Reusable Ear Specula Black - 3mm - 10pk

**HOP604** Riester Reusable Ear Specula Black - 4mm - 10pk

**HOP605** Riester Reusable Ear Specula Black - 5mm - 10pk

**HOP606** Riester Reusable Ear Specula Black - 9mm - 10pk

### Disposable ear specula for ri-scope® L1/L2, , e-scope, ri-mini® and pen-scope® otoscopes – Packs of 100:

- Selection of sizes: 2–5mm
- An especially hygienic option for the prevention of cross-contamination
- Made of blue plastic for single use

**HOP607** Riester Disposable Ear Specula Blue - 2mm - 100pk

**HOP608** Riester Disposable Ear Specula Blue - 2.5mm - 100pk

**HOP609** Riester Disposable Ear Specula Blue - 3mm - 100pk

**HOP610** Riester Disposable Ear Specula Blue - 4mm - 100pk

**HOP611** Riester Disposable Ear Specula Blue - 5mm - 100pk

### Disposable specula for ri-scope® L3 otoscope– Packs of 100:

- An especially hygienic option for the prevention of cross-contamination
- Made of blue plastic for single use
- The 9mm speculum is suitable for use as a nasal speculum
- Selection of different sizes: 2–9mm

**HOP612** Riester Disposable Ear Specula Blue - 2mm - 100pk

**HOP613** Riester Disposable Ear Specula Blue - 3mm - 100pk

**HOP614** Riester Disposable Ear Specula Blue - 4mm - 100pk

**HOP615** Riester Disposable Ear Specula Blue - 5mm - 100pk

**HOP616** Riester Disposable Ear Specula Blue - 9mm - 100pk

## Riester Bulbs



Riester bulbs for ophthalmoscope and otoscope ranges. Further ranges are available online.

Contact us for help with suitable bulbs for your device.



**HOP617** Riester 11440 XL 2.5V Bulb

**HOP618** Riester 11860 XL 2.5V Bulb

**HOP619** Riester 11862 XL 2.5V Bulb

**HOP620** Riester 11442 XL 3.5V Bulb

**HOP622** Riester 12033 XL 3.5V Bulb

**HOP631** Riester 10599 LED 3.5V Bulb – 6pk

**HOP632** Riester 10473 Vacuum Lamp XL 2.5V – 6pk

**HOP633** Riester 10489 Vacuum Lamp 2.5V – 6pk

## Primo Therasonic 360 and 460

The Primo Therasonic has been completely redesigned to offer you a wide range of choices for your ultrasound treatment programme.

Widely used to improve healing time on soft tissue injuries, it has integrated evidence based algorithms and clinical protocols.

- Colour Touch screen technology
- Dual frequency ultrasound (1MHz and/or 3MHz)
- Programmable memory Easy wipe clean for hygiene
- Mains powered as standard, Alternative battery option is also available for this unit
- **Treatment Protocols:** Pressure Ulcers, Chronic Venous Ulcers, Trigger Point Low irritability, Tendon Injury/ Lesion, Chronic Osteoarthritis, Rheumatoid Arthritis, Tennis Elbow, Carpal Tunnel, Fibromyalgia, Soft Tissue Stretch, Impingement Syndrome, Calcific Tendonitis, Perineal Pain (Persistent), Perineal Pain (Partum)
- **Treatment time:** 0-30 min
- **Dimensions:** 108 x 237 x 333mm
- **Weight:** 1.3 kg
- **Includes:** large treatment head and 250ml of coupling gel

**PHY115** 360 Colour Touchscreen - Mains and 1MHz Only

**PHY117** 460 Colour Touchscreen Dual Frequency - Mains Only

**PHY193** 460 Colour Touchscreen Dual Frequency - Mains/Battery



**PHY118** Large Dual Frequency Treatment Head

**PHY119** Small Dual Frequency Treatment Head

**PHY120** Coupling Medium 8 x 250 ml

**PHY121** Coupling Medium 1 litre bottles

**PHY122** Padded Carrying Case

**PHY123** Primo Treatment Trolley

**PHY124** Battery Pack - Factory Fitted

**PHY125** Ultrasound Output Indicator

## Primo Interferential 960

The Primo Interferential 960 uses a mid-frequency electrical signal to treat muscular spasms and strains which makes it particularly effective in treating acute injuries, especially injuries sustained from sports.

The interferential therapy is used to relieve pain, stimulate muscles, increase local blood flow and reduces oedema.

- Colour Touch screen technology
- 0-100mA peak constant or 0-70/140V peak constant voltage
- 2 independent output channels which allow for 2 different treatments
- Operates in conjunction with EMS vacuum unit if required
- Easy wipe clean reducing the risk of cross-infection
- Mains powered as standard, optional battery available
- **Treatment protocols:** Pain relief, Oedema, Stimulate local blood flow, OA Knee, Chronic low back pain, Acute low back pain, Fibromyalgia, Trigger points, Post operative knee pain, Fracture healing, Stress incontinence, Urge incontinence, Constipation (children)
- **Three carrier frequencies:** 2kHz, 4kHz and 8kHz
- **Dimensions:** 108 x 237 x 333mm
- **Weight:** 1.3 kg

### Complete with:

- 2/4-pole patient lead
- 4 electrode connection cables (blue and yellow)
- 4 medium (100 x 70mm) rubber electrodes
- 4 medium sponge covers and 2 bandages (1200 x 75mm)

**PHY190** 960 Colour Touchscreen - Mains only **£1,395.00**

**PHY191** 960B Colour Touchscreen - Mains/Battery **£1,665.00**



**PHY127** EMS Guide to Interferential

**PHY128** Small Sponge Electrode Covers (4)

**PHY129** Conductive Rubber Electrodes

**PHY130** Medium Sponge Covers

**PHY131** Medium Conductive Rubber Electrodes

**PHY132** Large Sponge Electrode Covers

**PHY133** Large Conductive Rubber Electrodes

**PHY134** 2/4 Pole Patient Lead

**PHY135** Blue Electrode Cables

**PHY136** Yellow Electrode Cables

**PHY137** Vaginal Probe

**PHY138** Anal Probe

## Primo Multidyne 970

Stimulation therapy used for rehabilitation purposes, preventing muscle atrophy caused by musculoskeletal injuries, such as damage to bones, muscles, ligaments and tendons.

- Colour Touch screen technology
- Operates in conjunction with EMS vacuum unit if required
- Easy wipe clean reducing the risk of cross-infection
- 0-100mA peak const. current / 0-70/140V peak const. voltage
- Mains powered as standard, optional battery available
- **Three carrier frequencies:** 2kHz, 4kHz and 8kHz
- **Treatment protocols:** Same as for interferential 2 independent output channels allowing 2 different treatments
- **Stimulation on the Primo Multidyne 970 includes:** Interferential (2/4-pole), Russian, Diadynamic, TENS, Sinusoidal, Faradic, Galvanic, Interrupted Galvanic, Trabert, Medi-Wave and Microcurrent and S/D curve
- **Dimensions:** 108 x 237 x 333mm
- **Weight:** 1.5kg

### Supplied With:

- 4 electrode connection cables (blue and yellow)
- 4 medium (100 x 70mm) rubber electrodes
- 2 stretch bandages (1200 x 75mm)
- 4 medium sponge covers
- 2/4-pole patient lead

**PHY139** 970 Colour Touchscreen - Mains Only

**PHY140** 970B Colour Touchscreen - Mains/Battery

**PHY122** Padded Carrying Case

**PHY123** Primo Treatment Trolley



**PHY141** Stretch Bandage 600 x 75mm

**PHY142** Stretch Bandage 1200 x 75mm

**PHY143** Stretch Bandage 600 x 50mm

**PHY144** Self Adhesive Electrodes 33 x 54

**PHY145** Self Adhesive Electrodes 50 x 50

**PHY146** Self Adhesive Electrodes 75 x 100

**PHY147** Self Adhesive Electrodes 25mm dia

**PHY127** EMS Guide to Interferential

## Primo Combination 860

The Primo Combination 860 offers dual frequency ultrasound (1 and 3MHz) and the complete range of stimulation outputs can be used individually or simultaneously in combination therapy.

- Touch screen technology & Dual frequency ultrasound
- Operates in conjunction with EMS vacuum unit if required
- Mains powered as standard, optional battery available
- **Stimulation outputs:** two and four pole interferential, Diadynamic, TENS, Sinusoidal, Galvanic and interrupted galvanic, Faradic, Trabert, Medi-Wave, Russian & Microcurrent output Diagnostic feature to help locate difficult to pinpoint lesions
- **Treatment protocols:** (same as ultrasound/stimulation units) 2 independent output channels allow 2 different treatments
- **Dimensions:** 108 x 237 x 333mm
- **Weight:** 1.5kg

### Supplied with:

- 2 stretch bandages (1,200 x 75mm)
- 4 medium (100 x 70 mm) rubber electrodes
- 4 electrode connection cables (blue and yellow)
- 250 ml bottle of coupling medium
- 4 medium sponge covers
- Large treatment head
- 2/4 pole patient lead

**PHY148** Primo Combi 860 Therapy Unit - Mains Only

**PHY149** Primo Combi860 Therapy Unit - Mains/Battery

**PHY118** Large Dual Frequency Treatment Head

**PHY119** Small Dual Frequency Treatment Head



**PHY141** Stretch Bandage 600 x 75mm

**PHY142** Stretch Bandage 1200 x 75mm

**PHY143** Stretch Bandage 600 x 50mm

**PHY144** Self Adhesive Electrodes 33 x 54

**PHY145** Self Adhesive Electrodes 50 x 50

**PHY146** Self Adhesive Electrodes 75 x 100

**PHY147** Self Adhesive Electrodes 25mm dia



**Further Accessories:**

PHY127	EMS Guide to Interferential
PHY128	Small Sponge Electrode Covers (4)
PHY129	Conductive Rubber Electrodes
PHY130	Medium Sponge Covers
PHY131	Medium Conductive Rubber Electrodes
PHY132	Large Sponge Electrode Covers
PHY133	Large Conductive Rubber Electrodes

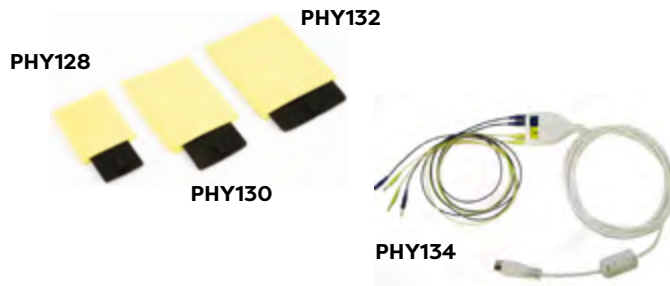

PHY122	Padded Carrying Case
PHY123	Primo Treatment Trolley
PHY134	2/4 Pole Patient Lead
PHY135	Blue Electrode Cables
PHY136	Yellow Electrode Cables
PHY137	Vaginal Probe
PHY138	Anal Probe

### Primo Radial Shockwave

The Primo Shockwave device provides energy through an electromechanical process opposed to compressed mechanical energy, thereby providing a comfortable patient experience.

Extracorporeal Shockwave using the Primo Radial Shockwave unit is fast becoming one of the most popular modalities used in any modern clinic.

- Energy levels from 60–180 mJ (equivalent to 1–5 bar)
- Pulse frequencies 8–22 Hz
- Burst mode for trigger point treatment
- Positive and negative shockwave counter
- 16 user defined treatment suggestions
- Preset treatment suggestions for common injuries
- Total treatment energy displayed

**This product is supplied complete with:**

Handpiece & Footpiece, 6mm/15mm/25mm applicator tips

PHY207	Primo Radial Shockwave
PHY213	Carrying case



PHY208	Replacement handpiece
PHY209	Replacement footswitch
PHY210	6mm applicator tip
PHY211	15mm applicator tip
PHY212	25mm applicator tip

### Vacuum 660 Unit

The Vacuum 660 unit is designed to be integrated with the existing MK2 Primo range of units, a lightweight option.

- Pulsed or continuous vacuum
- Powerful new super-quiet vacuum with virtually no vibration
- 2 Channel selection option:  
Channels A and B or Channel A or B only
- Supplied with complete set of accessories
- Independent cup suction capability
- Optional shoulder bag
- **Weight:** 1.5 kg
- **Dimensions:** 65 x 210 x 100 mm
- **Complete with:** four vacuum electrode cups (60mm) each with sponge inserts, four vacuum electrode leads and one link lead to connect unit to interferential / stimulation/ combination unit

PHY194	EMS Vacuum unit
--------	-----------------



PHY195	Link lead to Primo 960 or Primo 970
PHY196	Vacuum Cup – Grey, 60mm
PHY197	Vacuum Lead – Red
PHY198	Vacuum Lead – Black
PHY199	Vacuum Cup Sponge Inserts – 4pk



## Megapulse Senior 265

An innovative, stylish and practical addition to the new generation of EMS equipment. Megapulse Senior 265 offers pulsed and continuous shortwave therapy with many additional features, from one of the world's largest specialised manufacturers of shortwave therapy products.

- 1,000W pulsed and 400W continuous maximum power
- Optional treatment protocols, based on proven results
- Continuous and pulsed shortwave from one unit Back-lit display with clear operational information
- Simple quick set-up 10 programmable memory functions
- Distinctive ergonomic design with rugged, lockable castors
- Up to 30 minutes treatment time
- **Wide range of pulse widths:** 20 - 400 microseconds
- **Wide range of pulse frequencies:** 5 - 800 pulses per second
- **Output modes:** continuous/pulsed 1 in 3, 2 in 3 or 3 in 3
- **Dimensions:** 470 x 470 x 940mm
- **Weight:** 38kg
- **Includes:** two electrode arms, two 100mm capacitive electrodes with cables, output tester and user manual

**PHY167** Megapulse Senior 265



**PHY168** Monopulse Inductive Applicator

**PHY169** Flexipulse Inductive Applicator

**PHY170** 100mm Capacitive Electrodes and Cable - One Pair

**PHY171** 50mm Capacitive Electrodes and Cable - One Pair

**PHY172** Rubber Pad Electrodes 180 x 120mm

**PHY173** Felt Spacers for Above

**PHY174** Rubber Pad Electrodes 260 X 180mm

**PHY175** Felt Spacers for Above

## SISSEL Basic Portable Massage Table

The Sissel Basic Portable Massage Table is a handy folding, lightweight massage table for use in the home, even in confined spaces. Its soft cushioning and memory foam top layer offer additional comfort.

Comfortable Visco elastic memory foam top layer (for comfort) bonded to a layer of high density foam (for stability) to produce a durable foam platform, offering the perfect relaxation aid for better massage.

- Ideal for partner massage after a hard day at work
- Lightweight and easy set up - even in confined spaces
- Folds flat for easy storage in the carry case
- Blue "leather" like, durable, easy to clean surface
- Removable breath hole with bung

### Specification:

- **Platform dimensions:** 175 x 60cm
- **Height adjustable:** 60 to 80cm
- **Weight:** 13kg
- **Maximum user weight:** 215kg



**FURN-05** SISSEL Basic Massage Table - Blue with Bag

## SISSEL Robust Portable Massage Table

Includes a range of enhanced features for improved user comfort and better positioning on the platform. Centre folding and lightweight to be used portably on location.

This larger, stronger platform improves on the basic model, with a larger maximum user weight and is supported on taller legs, increasing the height of the platform.

- Includes the addition of arm rests an adjustable, removable headrest and sturdy carry case
- Pleasant and soft cushioning aids relaxation helping towards a perfect massage
- Lightweight and easy set up, parts slot into base
- Blue "leather" like, durable, easy to clean surface
- Removable breath hole with bung

### Specification:

- **Platform dimensions:** 188 x 72cm
- **Height adjustable:** 63 to 87cm
- **Weight:** 19kg
- **Maximum user weight:** 245kg



**FURN-06** SISSEL Robust Massage Table - Blue with Bag

## Polar 8 Hour Vaccine Bag

Specifically designed to maintain a temperature of between 2–8°C, for up to a max of 8 hours with the correct use of cooling blocks. The bag is made of our patented Polartherm™ materials.

- **Cool blocks included:** 4
- **Storage capacity:** 12–24 vials
- **Weight with coolant:** 5 kgs
- **External & Internal material:** Cotton coated PVC
- **Insulation thickness:** 45mm
- **External dimensions:** 350 x 450 x 350mm
- **Internal dimensions:** 300 x 400 x 300mm
- **Capable of a 17 hour cold life if zip lid is unopened**



**HRF087** Polar 8 Hour Vaccine Bag



**HRF086** Clamshell Vaccine Bag

## Polar Clamshell Vaccine Bag

Our most compact and light bag, this can hold up to 12 standard size vaccines, ideal for anyone with 2/3 calls to make. Maintains a temperature of between 2–8°C, for up to a max of 4 hours with correct use of cooling blocks

- **Waterproof, anti-fungal with rot proof stitching**
- **Cool blocks included:** 2
- **Storage capacity:** 2 Litres
- **Weight empty:** 2 kgs
- **External and Internal materials:** Cotton coated PVC
- **External dimensions:** 300 x 120 x 270mm
- **Internal dimensions:** 250 x 70 x 200mm

## Polar Thermal/ Vaccine Bags

Thermal bags suitable for the transport of vaccines & medicals. Can use gels to extend performance but with increased weight.

Will maintain a product temperature between 2–8°C for up to a maximum for 4 hours when in use. All materials are waterproof, have rot proof stitching, are antifungal and come with a two year guarantee, subject to normal wear and tear.

### 10 Litre Thermal Bag

- Estimated capacity 80 HPV packs (without blocks)
- Weight: 0.76kg
- External Dimensions: 400 x 220 x 280mm
- Internal Dimensions: 355 x 175 x 235mm
- **Recommended Accessories:** 10L Patient Safety Pack

### 20 Litre Thermal Bag

- Estimated capacity 120 HPV packs (without blocks)
- Weight: 0.93kg
- External Dimensions: 400 x 330 x 280mm
- Internal Dimensions: 355 x 285 x 235mm
- **Recommended Accessories:** 20L Patient Safety Pack

### 30 Litre Thermal Bag

- Estimated capacity 220 HPV packs (without blocks)
- Weight: 1.10kg
- External Dimensions: 480 x 300 x 350mm
- Internal Dimensions: 435 x 265 x 305mm
- **Recommended Accessories:** 30L Patient Safety Pack

### 75 Litre Thermal Bag

- Estimated capacity 460 HPV packs (without blocks)
- Weight: 1.36kg
- External Dimensions: 640 x 350 x 440mm
- Internal Dimensions: 595 x 315 x 395mm
- **Recommended Accessories:** Portable wheeled trolley



2 Year Warranty

**HRF084**



**HRF080**



**HRF079**



**HRF078** Polar 10L Thermal Carry Bag

**HRF080** Polar 20L Thermal Carry Bag

**HRF082** Polar 30L Thermal Carry Bag

**HRF079** Polar 75L Thermal Bag

**HRF084** Polar Wheeled Trolley

**HRF078.1** Polar Temperature Data Logger Probe

**HRF078.2** Polar 10L Safety pack

**HRF080.1** Polar 20L Safety pack

**HRF082.1** Polar 30L Safety pack



# LABCOLD™

medical & scientific refrigeration

## IntelliCold® pharmacy refrigeration

*Innovative, intuitive, intelligent*

### Door Lock

Key lock fitted as standard.

Digital locks, which eliminate the problems of lost and generic keys are an optional extra and available on all models apart from RLDF/G1819.



### Remote Alarm Connection

Can also be used for the Labcold Repeat Alarm.



### Touch Screen Controller

Displays temperature reading from both temperature probes

High and Low temperature alarm

Minimum/maximum temperature recording

Door open alarm

Mains Failure alarm

24/7 minute by minute temperature data recording

Optional Micro SD card available to transfer data from the refrigerator to your computer for storage as a CSV/Excel file



Touch Screen Controller

### Second Temperature Probe

This independent 'wandering' probe can be placed anywhere within the refrigerator, for example in a packet to record the product temperature. Ideal for wholesale pharmacists needing to comply with MHRA regulations.

### Alarm Battery Back Up

Fit batteries (not supplied) to your refrigerator and it will alarm if there is an interruption in mains power plus the controller will continue to record temperature data.



LED Light

Fan Assisted Cooling

Self Closing Door

### Choice of Glass or Solid Door

Labcold IntelliCold® Pharmacy Range is available in a variety of sizes from 36 to 543 litres in storage capacity. Every model is available with a solid or glass door option.

Access Port



## Labcold IntelliCold® Pharmacy Refrigeration Features



Is there a **FREE** Labcold penguin in your new pharmacy fridge?

Selected refrigerators in the Labcold pharmacy range are available to 'penguin' owners.

- Touch Screen IntelliCold® controller
- 24/7 automatic temperature data logging
- Alarm battery back up
- Power fail alarm (if batteries are fitted)
- Remote alarm contacts
- Digital temperature display
- Door lock with two keys/digital lock option
- High/low temperature alarm
- Second independent temperature probe
- Minimum/maximum temperature recording with reset
- Internal LED light on all models
- Fan assisted cooling
- Off cycle auto defrost
- Low GWP Environmentally friendly refrigerant
- Self closing door with door open alarm
- Adjustable shelves
- Access port
- **FREE 5 year warranty (UK only)**

## Labcold 36L Bench Top Refrigerator

A professional pharmacy refrigerator powered by our IntelliCold® touch screen controller, designed from the ground up for the safe storage of cold chain medicines as advised by Public Health England in Protocol for Ordering, Storing and Handling Vaccines.

Features a 1 metre secondary temperature probe that can be placed anywhere inside the fridge and it features a touch screen controller which is completely flat for thorough cleaning. The controller displays, alarms and records minimum and maximum temperatures for both temperature probes. The screen locks after 30 secs to ensure buttons can't be activated accidentally.

- **Gross Capacity: 36 litres**
- **External dimensions (H W D) 538 x 450 x 510mm**
- **Weight: 30kg**
- **Shelves: 2**
- Temperature: +2°C to +8°C
- IntelliCold® touch screen
- Option of key or digital lock
- Temperature display
- Hi/Lo temperature alarm
- Door open alarm
- Mains failure alarm
- Max/Min temp. recording
- Alarm battery backup
- Off cycle auto defrost
- Fan assisted cooling
- Access port
- Remote alarm contact
- Self closing door
- Brackets for wall mounting
- Internal light
- Integral temp. data logging
- **Free Five year parts & labour warranty**
- **Compliant with all leading professional guidelines**

<b>HRF340</b>	Solid Door – RLDF0119
<b>HRF340.1</b>	Solid Door with Digital Lock – RLDF0119DIGLOCK
<b>HRF341</b>	Glass Door – RLDG0119
<b>HRF341.1</b>	Glass Door with Digital Lock – RLDG0119DIGLOCK



**HRF340**



**HRF340.1**



**HRF341.1**



## Labcold 66L Bench Top Refrigerator

A professional pharmacy refrigerator powered by our IntelliCold® touch screen controller, designed from the ground up for the safe storage of cold chain medicines as advised by Public Health England in Protocol for Ordering, Storing and Handling Vaccines.

Features a 1 metre secondary temperature probe that can be placed anywhere inside the fridge and it features a touch screen controller which is completely flat for thorough cleaning. The controller displays, alarms and records minimum and maximum temperatures for both temperature probes. The screen locks after 30 secs to ensure buttons can't be activated accidentally.

- **Gross Capacity: 66 litres**
- **External dimensions (H W D) 740 x 450 x 510mm**
- **Weight: 34kg**
- **Shelves: 3**
- Temperature: +2°C to +8°C
- IntelliCold® touch screen
- Option of key or digital lock
- Temperature display
- Hi/Lo temperature alarm
- Door open alarm
- Mains failure alarm
- Max/Min temp. recording
- Alarm battery backup
- Off cycle auto defrost
- Fan assisted cooling
- Access port
- Remote alarm contact
- Self closing door
- Brackets for wall mounting
- Internal light
- Integral temp. data logging
- **Free Five year parts & labour warranty**
- **Compliant with all leading professional guidelines**

<b>HRF342</b>	Solid Door – RLDF0219
<b>HRF342.1</b>	Solid Door with Digital Lock – RLDF0219DIGLOCK
<b>HRF347</b>	Glass Door – RLDG0219
<b>HRF347.1</b>	Glass Door with Digital Lock – RLDG0219DIGLOCK



**HRF340**



**HRF340**



**HRF340**



## Labcold 150L Undercounter Refrigerator

A professional pharmacy refrigerator powered by our IntelliCold® touch screen controller, designed from the ground up for the safe storage of cold chain medicines as advised by Public Health England in Protocol for Ordering, Storing and Handling Vaccines.

Features a 1 metre secondary temperature probe that can be placed anywhere inside the fridge and it features a touch screen controller which is completely flat for thorough cleaning. The controller displays, alarms and records minimum and maximum temperatures for both temperature probes. The screen locks after 30 secs to ensure buttons can't be activated accidentally.

- **Gross Capacity: 150 litres**
- **External dimensions (H W D) 835 x 600 x 600mm**
- **Weight: 51kg**
- **Shelves: 3**
- Temperature: +2°C to +8°C
- IntelliCold® touch screen
- Option of key or digital lock
- Temperature display
- Hi/Lo temperature alarm
- Door open alarm
- Mains failure alarm
- Max/Min temp. recording
- Alarm battery backup
- Off cycle auto defrost
- Fan assisted cooling
- Access port
- Remote alarm contact
- Self closing door
- Internal light
- Integral temp. data logging
- **Free Five year parts & labour warranty**
- **Compliant with all leading professional guidelines**

HRF346	Solid Door – RLD0519
HRF346.1	Solid Door with Digital Lock – RLD0519DIGLOCK
HRF343	Glass Door – RLDG0519
HRF343.1	Glass Door with Digital Lock – RLDG0519DIGLOCK



HRF346



HRF346.1



HRF343.1



5 Year Warranty



## Labcold 340L Freestanding Refrigerator

A professional pharmacy refrigerator powered by our IntelliCold® touch screen controller, designed from the ground up for the safe storage of cold chain medicines as advised by Public Health England in Protocol for Ordering, Storing and Handling Vaccines.

Features a 1.6 metre secondary temperature probe that can be placed anywhere inside the fridge and it features a touch screen controller which is completely flat for thorough cleaning. The controller displays, alarms and records minimum and maximum temperatures for both temperature probes. The screen locks after 30 secs to ensure buttons can't be activated accidentally.

- **Gross Capacity: 340 litres**
- **External dimensions (H W D) 1510 x 600 x 700mm**
- **Weight: 91kg**
- **Shelves: 6**
- Temperature: +2°C to +8°C
- IntelliCold® touch screen
- Option of key or digital lock
- Temperature display
- Hi/Lo temperature alarm
- Door open alarm
- Mains failure alarm
- Max/Min temp. recording
- Alarm battery backup
- Off cycle auto defrost
- Fan assisted cooling
- Access port
- Remote alarm contact
- Self closing door
- Internal light
- Integral temp. data logging
- **Free Five year parts & labour warranty**
- **Compliant with all leading professional guidelines**

HRF348	Solid Door – RLD0519
HRF348.1	Solid Door with Digital Lock – RLD0519DIGLOCK
HRF349	Glass Door – RLDG0519
HRF349.1	Glass Door with Digital Lock – RLDG0519DIGLOCK



HRF349.1



HRF348



5 Year Warranty



## Labcold 440L Freestanding Refrigerator

A professional pharmacy refrigerator powered by our IntelliCold® touch screen controller, designed from the ground up for the safe storage of cold chain medicines as advised by Public Health England in Protocol for Ordering, Storing and Handling Vaccines.

Features a 1.6 metre secondary temperature probe that can be placed anywhere inside the fridge and it features a touch screen controller which is completely flat for thorough cleaning. The controller displays, alarms and records minimum and maximum temperatures for both temperature probes. The screen locks after 30 secs to ensure buttons can't be activated accidentally.

- **Gross Capacity: 440 litres**
- **External dimensions: (H W D) 1875 x 600 x 700mm**
- **Weight: 93kg**
- **Shelves: 6**
- Temperature: +2°C to +8°C
- IntelliCold® touch screen
- Option of key or digital lock
- Temperature display
- Hi/Lo temperature alarm
- Door open alarm
- Mains failure alarm
- Max/Min temp. recording
- Alarm battery backup
- Off cycle auto defrost
- Fan assisted cooling
- Access port
- Remote alarm contact
- Self closing door
- Internal light
- Integral temp. data logging
- **Free Five year parts & labour warranty**
- **Compliant with all leading professional guidelines**

<b>HRF344</b>	Solid Door – RLDF1519
<b>HRF344.1</b>	Solid Door with Digital Lock – RLDF1519DIGLOCK
<b>HRF350</b>	Glass Door – RLDG1519
<b>HRF350.1</b>	Glass Door with Digital Lock – RLDG1519DIGLOCK



**HRF344**

**HRF350.1**



## Labcold 543L Freestanding Refrigerator

A professional pharmacy refrigerator powered by our IntelliCold® touch screen controller, designed from the ground up for the safe storage of cold chain medicines as advised by Public Health England in Protocol for Ordering, Storing and Handling Vaccines.

Features a 1.6 metre secondary temperature probe that can be placed anywhere inside the fridge and it features a touch screen controller which is completely flat for thorough cleaning. The controller displays, alarms and records minimum and maximum temperatures for both temperature probes. The screen locks after 30 secs to ensure buttons can't be activated accidentally.

- **Gross Capacity: 543 litres**
- **External dimensions (H W D) 1960 x 750 x 755mm**
- **Weight: 120kg**
- **Shelves: 5**
- Temperature: +2°C to +8°C
- IntelliCold® touch screen
- Option of key or digital lock
- Temperature display
- Hi/Lo temperature alarm
- Door open alarm
- Mains failure alarm
- Max/Min temp. recording
- Alarm battery backup
- Off cycle auto defrost
- Fan assisted cooling
- Access port
- Remote alarm contact
- Self closing door
- Internal light
- Integral temp. data logging
- **Free Five year parts & labour warranty**
- **Compliant with all leading professional guidelines**

<b>HRF363</b>	Solid Door – RLDF1819
<b>HRF364</b>	Glass Door – RLDG1819



**HRF363**

**HRF364**



## Labcold Refrigerator Options

Optional extras can be purchased with your Labcold refrigerator to further improve its performance and meet your personal requirements.

You can choose from fridge alarms, drawer organisers, door locks and even calibration certificates all provided by Labcold, so you can trust in the quality and reliability.

## Labcold Repeat Alarm

This unit plugs into the Labcold accessory socket with the cabling run outside of the room. The unit is then wall mounted and will give an audio/visual alarm if the fridge goes over or under the temperature behind closed doors.



HRF251 Labcold Repeat Alarm

## Labcold Micro SD Card

The IntelliCold® controller automatically stores readings from the two temperature probes, plus any alarms and info about the fridge itself, such as whether the door was open or if the compressor is running.

This data is collected and saved every minute, 24/7, 365 days of the year. As long as the battery back-up compartment is powered by four live AA batteries data will be recorded and stored on this card.

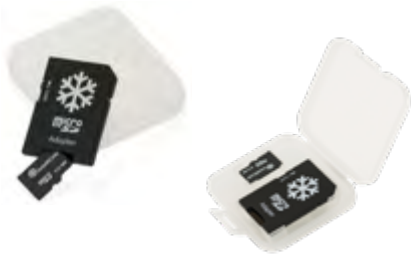

HRF352 Micro SD Card

## Calibration Certificate

For complete conformity and peace of mind, you can purchase a manufacturer's calibration certificate proving that the temperature displayed is accurate.

Labcold are a UKAS temperature calibration laboratory #8898, all aspects of calibration are carried out using UKAS methodology. This is especially useful for wholesale pharmacies and has become a requirement for some health authorities.



HRF263 Calibration Certificate

## Labcold Divided Drawers

Designed for use in the RLDF/G1019 and 1519 ONLY

- Easy glide mechanism
- Ventilated for maximum air circulation
- Can be used in conjunction with shelves
- Maximises storage space
- Simple to install in fridge
- Can be retro fitted
- Aids stock rotation and helps prevent clutter



HRF353 Plastic Divided Drawers

## Labcold Data Logger

Specially designed for the monitoring of the pharmaceutical cold chain and are ideal for using when vaccines or in transit or as an independent thermometer for your vaccine refrigerator.

With an LED screen which can display alarm alerts in real time, these waterproof loggers plug directly into a USB PC port for configuration, data download and analysis via free software.

- **Free software – Windows compatible only**
- Creates a PDF report which includes a data curve, data report and all data points
- 2.0 A-Type USB connection
- Accuracy: +/-0.5 at -20°C to +40°C
- Up to 5 alarm settings programmable
- Adjustable sample rate
- Replaceable battery
- Visual alarm (if configured)



HRF354 Labcold Data Logger

## Labcold Temperature USB Loggers

Record time, date and precise temperature for later analysis. Sealed in a hygienic plastic casing, this logger can be located amongst product and has a green normal operation light and a red warning light to alert the user to temperature deviations.

The required software allows the user to download the data to a Windows enabled PC. Data can then be displayed graphically.

- **Temperature Range:** -30°C to +60°C
- **Dimensions:** 117 x 57 x 10mm
- **Total Weight:** 54g
- **Construction Materials:** ABS
- **Maximum data points:** 24,576
- **Battery life:** 4 years
- **Accuracy:** +/- 0.5°C
- **Resolution:** 0.02c
- **Software and Reader Required**



HRF271 Labcold Transport Temperature Loggers

HRF273 Reader for Transport Temperature Logger

## Lec Medical Large Capacity Refrigerators

- 2°C to 8°C temperature range
- External digital controller and temperature display showing air and core temperatures
- Fitted lock and 2 keys
- Audible and visual temperature alarms
- Monitoring software records air and load temperatures constantly and also holds a full 7 day alarm history, USB data download and power failure alarm (Included with all fridges except 444L versions)
- **Free Standard delivery for 444L fridge**
- **Extra carriage charge required for 600/1200L fridges – Contact us for more details**
- **Free WEEE collection of any fridge within 2 weeks of delivery**



Code	Model	Dimensions (mm)	Capacity	Warranty	Shelves/Baskets	Door
HRF043	PE1607C	685 x 1688 x 910	444L	5 Year	5 / 0	Solid
HRF042	PG1607C	685 x 1688 x 910	444L	5 Year	5 / 0	Glass
HRF206	PSR600UK	690 x 1995 x 840	600L	5 Year	5 / 0	Solid
HRF212	PGR600UK	690 x 1995 x 840	600L	5 Year	5 / 0	Glass
HRF207	PSR1200UK	1300 x 1995 x 840	1200L	5 Year	10 / 0	Solid
HRF213	PGR1200UK	1300 x 1995 x 840	1200L	5 Year	10 / 0	Glass

## Lec Medical Essential Refrigerators

All Lec Medical Pharmacy refrigeration conforms to storage standards laid out by The Royal Pharmaceutical Society of Great Britain (RPSGB)

- Ready to use with a default pre-set temperature range of between +2°C and +8°C
- Lock with 2 keys fitted as standard and guaranteed for the full warranty period of 2 years
- Open Door audible and visual alarms – warning if the door has been left open
- Choice of solid or glass doors
- Varying numbers of shelves and wire baskets
- 2 Year warranty included
- **Free Standard delivery**
- **Free WEEE collection of any fridge within 2 weeks of delivery**



Code	Model	Dimensions (mm)	Capacity	Warranty	Shelves/Baskets	Door
HRF301	PESR41UK	702 x 379 x 500	41L	2 Year	2 / 1	Solid
HRF312	PEGR41UK	702 x 379 x 500	41L	2 Year	2 / 1	Glass
HRF302	PESR47DC-UK	565 x 480 x 505	47L	2 Year	3 / 1	Solid
HRF304	PESR82UK	660 x 502 x 540	82L	2 Year	2 / 1	Solid
HRF314	PEGR82UK	660 x 502 x 540	82L	2 Year	2 / 1	Glass
HRF305	PESR107UK	830 x 495 x 620	107L	2 Year	2 / 1	Solid
HRF315	PEGR107UK	830 x 495 x 620	107L	2 Year	2 / 1	Glass
HRF316	PEGR107UK-LHH	830 x 495 x 620	107L	2 Year	2 / 1	Glass / Hinge on Left





Free Delivery



5 Year Warranty



## Lec Medical Pharmacy Plus Refrigerators

All Lec Medical Pharmacy refrigeration conforms to storage standards laid out by The Royal Pharmaceutical Society of Great Britain (RPSGB)

**Cloud Connected Controller** – Remote temperature monitoring, adjustment, and alarm history via encrypted secure cloud storage over a wireless or Bluetooth connection.

**Smartphone App & Online Portal** – Contactless remote monitoring of air and load temperatures via app or online portal.

**Intelligent Fan Management** – Smart fan optimisation aids in temperature stability following door openings, minimising fan activity when door is open.

**Dual Probe Temperature Monitoring** – Offers greater temperature accuracy within your appliance, simultaneously measuring both air and product temperatures.

- User friendly external digital controller & temperature display
- Ready to use with a default pre-set temperature range of between +2°C and +8°C
- Represents your vaccine vial
- Provides you with the true temperature of your vaccines
- Will ensure you always measure what matters
- Has a built-in warning system for safe guarding vaccines
- Forced Air Cooling to ensure best temperature stability
- Controller Temperature Display Accuracy to 0.1°C on most Lec Medical solid door models
- Anti-Microbial Handle helps prevent growth of bacteria and minimises cross contamination
- Open Door Sensors and alarms to warn if the door is open
- Door activated LED light switch – making it even easier to see stock at a glance
- Fully removable door seal on all glass door models
- New Access port in back of fridge to utilise temperature monitoring cables.
- Energy Efficient R600a Refrigerant on most models which is kinder to the environment with reduced running costs
- Storage Flexibility with adjustable shelf heights to maximise the storage potential
- Auto Defrost Feature ensures the most efficient cooling
- **Free Standard delivery**
- **Free WEEE collection of any fridge within 2 weeks of delivery**

Code	Model	Dimensions (mm)	Capacity	Warranty	Shelves/Baskets	Door
HRF106.1	PPSR47BT-UK	565 x 475 x 445	47L	5 Year	2 / 1	Solid
HRF106	PPGR47BT-UK	565 x 475 x 445	47L	5 Year	2 / 1	Glass
HRF107.1	PPSR158BT-UK	850 x 595 x 660	158L	5 Year	3 / 1	Solid
HRF107	PPGR158BT-UK	850 x 595 x 660	158L	5 Year	3 / 1	Glass
HRF108.1	PPSR158BT-DWP	850 x 595 x 660	158L	5 Year	3 / 1	Solid / Sliding Drawers
HRF108	PPGR158BT-DWP	850 x 595 x 660	158L	5 Year	3 / 1	Glass / Sliding Drawers
HRF109	PPGR158BT-LHH	850 x 595 x 660	158L	5 Year	3 / 1	Glass / Hinge on Left
HRF110.1	PPSR310BT	1560 x 595 x 660	273L	5 Year	5 / 1	Solid
HRF110	PPGR310BT	1560 x 595 x 660	273L	5 Year	5 / 1	Glass
HRF112.1	PPSR400BT	1935 x 595 x 660	353L	5 Year	6 / 1	Solid
HRF112	PPGR400BT	1935 x 595 x 660	353L	5 Year	6 / 1	Glass

## Lec Medical Ward Refrigerators

- Ready to use with a pre-set temperature range of +1°C to +5°C to keep food at the optimum temperature
- Forced air cooling to ensure best temperature stability
- Controller temp. display accuracy to 0.1°C on most models
- Anti-Microbial handle helps prevent growth of bacteria and minimises cross contamination
- Control panel lock avoiding any accidental changes to fridge settings
- Open Door Sensors and alarms to warn if the refrigerator door has been left open
- Storage Flexibility with adjustable shelf heights
- Advanced Controller enables you to see min/max temperatures and manage the warning alarm system
- Internal LED light (except WSR82UK)
- Auto defrost feature ensures the most efficient cooling
- Lock with 2 keys fitted as standard
- Heavy duty Wire Shelves for optimal air circulation
- Entire ward range is built in the UK
- Free 2 year parts and labour warranty providing you with peace of mind
- **Free Standard delivery**
- **Free WEEE collection of fridge within 2 weeks of delivery**

HRF336 WSR82DC-UK

HRF130 WSR158DC-UK

HRF131 WSR310DC-UK



**WSR82DC-UK**

- **Gross:** 82L
- **Storage:** 2 shelves, 1 basket
- **Size:** 495 x 540 x 660
- **Weight:** 27.5kg



**WSR158DC-UK**

- **Gross capacity:** 158L
- **Storage:** 3 shelves, 1 basket
- **Size:** 595 x 660 x 850
- **Weight:** 33.25kg

Lec  
MEDICAL



2 Year  
Warranty



Made in  
the UK



Free  
Delivery



**WSR310DC-UK**

- **Gross capacity:** 310 Litres
- **Storage:** 5 shelves
- **Size:** 595 x 660 x 1560mm
- **Weight:** 50kg



DOMETIC

## Dometic DS301H Refrigerator

### 28 Litre Capacity pharmacy refrigerator

- Circulation from internal fan can increased performance
- Maximum temperature differential +/- 2 degrees C.
- Internal fan reduces frost build up on cooling fins
- Lockable with two 'door open' alarms
- Interior draw fronts protect from external temperatures
- Improved electronics in thermostatic controller
- Absorption cooling system for noiseless running
- Store heat sensitive medicines between 2-8°C
- Wall mounting option
- Manual Defrost
- **Outer dimensions:** 580 x 422 x 393mm
- **Weight:** 16kg

HRF006 Dometic DS301H Refrigerator

## Dometic DS601H Refrigerator

### 53 Litre Capacity pharmacy refrigerator

- Circulation from internal fan can increased performance
- Maximum temperature differential +/- 2 degrees C.
- Internal fan reduces frost build up on cooling fins
- Lockable with two 'door open' alarms
- Interior draw fronts protect from external temperatures
- Improved electronics in thermostatic controller
- Absorption cooling system for noiseless running
- Store heat sensitive medicines between 2-8°C
- Wall mounting option
- Manual Defrost
- **Outer dimensions:** 592 x 486 x 494mm
- **Weight:** 20kg

DOMETIC



HRF008 Dometic DS601H Refrigerator

## Labcold Vaccine Carry Bags

The ideal option for transporting vaccines. Tested and validated to hold between +2 and +8°C. Minimum temperature hold is 6-7.5 hours, dependent on ambient temperature, bag openings and product load. These carry bags can take additional gel packs/blocks at the discretion of the user.

### Wallet Vaccine Carrier

- External Dimensions: 350 x 430 x 340mm
- Internal Dimensions: 300 x 415 x 315mm
- Recommended Cool Packs: 6x Gel packs and 4x Cool blocks

### Small Carry Bag

- External Dimensions: 350 x 430 x 340mm
- Internal Dimensions: 300 x 415 x 315mm
- Recommended Cool Packs: 6x Gel packs and 4x Cool blocks

### Medium Carry Bag

- External Dimensions: 350 x 430 x 340mm
- Internal Dimensions: 300 x 415 x 315mm
- Recommended Cool Packs: 6x Gel packs and 4x Cool blocks

### Large Carry Bag

- External Dimensions: 350 x 430 x 340mm
- Internal Dimensions: 300 x 415 x 315mm
- Recommended Cool Packs: 6x Gel packs and 4x Cool blocks

<b>HRF367</b>	Wallet Size (110 x 370 x 270mm)
<b>HRF368</b>	Small Carry Bag (220 x 410 x 280mm)
<b>HRF369</b>	Medium Carry Bag (340 x 410 x 280mm)
<b>HRF370</b>	Large Carry Bag (350 x 430 x 340mm)



<b>HRF370.1</b>	Trolley for Carry Bags (Suitable for Medium & Large)
<b>HRF370.2</b>	Single Gel Pack
<b>HRF370.3</b>	Rigid Cool Block
<b>HRF354</b>	Labcold Data Logger

## Labcold Portable Vaccine Carriers

There is an easy to read digital temperature display, accurate to one decimal place. Can be calibrated so you can be confident that the temperature displayed is correct. Using a thermoelectric, solid state cooling system means no dangerous liquids or any moving parts which could be damaged.

- **Temp range:** +2 to +10°C
- **Capacity:** 12 or 19 Litres
- Supplied with mains and in-car power cables, shoulder strap, interior dividers and lid cushion
- Tough plastic exterior and top insulation pad
- Safe gas free peltier refrigeration
- Digital temperature display
- Easy digital temperature adjustment



\*Product not designed to be run for extended periods, nor to hold temperature when not connected to power source. Also not suitable for the transport of blood or blood products.



<b>HRF059.1</b>	12L Capacity Vaccine Carrier
<b>HRF059.2</b>	19L Capacity Vaccine Carrier

## Lec Medical Portable Vaccine Coolers

- +2°C to +8°C operating temperature range
- External LED temperature display
- Aluminium heat preserving foil lining
- Covered bung non slip feet

### 8L Portable Cooler Specification

- Holds temperature inside between 2–8°C for up to 17 hours
- Typical vaccine storage 2.5–3L
- Includes 9 gel packs
- Dimensions: 240 x 340 x 210mm
- Weight: 1.4kg

### 18L Portable Cooler Specification

- Typical vaccine storage 12–13L
- Holds temperature inside between 2°–8°C for up to 30 hours
- Webbing adjustable shoulder strap
- Includes 12 gel packs
- Dimensions: 310 x 440 x 285mm
- Weight: 4.03kg



<b>HRF365</b>	Lec Medical 8 Litre Portable Vaccine Cooler
<b>HRF365.1</b>	Lec Medical 18 Litre Portable Vaccine Cooler

## Lec Medical ATMDL01 Data Logger

- Connects directly to a USB port
- Huge data capacity without the need to frequently download the readings, Stores 16,382 readings
- Measurement range -35°C to +80 °C, Can be used in all types of freezers and refrigerators within this temperature range
- All the necessary software is included in the price (Download)
- IP67 standard Moisture protection
- Temperatures can be set to desired setting, whether it's a Pharmacy, Ward or Laboratory fridge or freezer
- Visual flashing LED status indicators to warn for temperatures going above or below set parameters and to notify user that the logger's battery is low



HRF077 ATMDL01 Data Logger

## Lec Medical ATMDL-LCD Data Logger

- Download code, containing the configuration software
- IP67 protection (when protective cap is fitted)
- High contrast LCD, with 2½ digit temperature display function
- Temperature measurement range of -35°C to +80°C
- Capable of storing up to 16,382 readings
- Choice of immediate, delayed and push-to- start logging
- User-programmable alarm thresholds
- Status indication via red, yellow or green LED's
- Dimensions: 119.5mm x 22.1mm x 25.3mm

### EL-WIN-USB (Control Software) features:

- °C or °F Logging Rate (10s, 1m, 5m, 30m, 1h, 6h, 12h)
- Immediate, delayed & push-to-start settings
- Display off, on for 30 sec after button press, or always on
- Data Rollover allows unlimited logging periods by overwriting the oldest data when the memory is full



HRF262 ATMDL-LCD Data Logger

## Lec Medical ATMDL01 Data Logger

Wirelessly stream and view data via WiFi on PC or Lec Medical Cloud. Subscription required (See below).

- Thermistor probe temperature measurement range
- Easy sensor set-up using free PC software application
- Configurable high and low alarms with indicator
- View and analyse multiple sensors, including graphing of historic data
- Sensor memory stores all data even if WiFi is disconnected
- Peace of mind with alerts for any temperature set points
- **Range:** -40 to +125°C (with accuracy +/-0.6°C)
- **Two probes:** Air & Load (Glycol liquid)
- **Power:** Rechargeable battery or mains operation
- **Dimensions:** 82 x 70 x 36mm(W x H x D)

### Cloud Subscription

- 12 months subscription package for up to 3 loggers.
- View data from multiple data loggers across multiple sites
- Assign multiple users to access
- View, export and print data from your logger
- Set up email alerts providing alarm and status reports
- Broadcast daily summary emails



HRF077.3 Dual Probe Cloud Based Wifi Temperature Logger

HRF077.2 1 Year Cloud Subscription (For Wifi Data Logger)

## Labcold ITV Cubed Ice Maker

**Designed to produce hygienic cylindrical ice from tap water.**

Utilising the latest technology this ice make has been designed for minimum maintenance.

For the production and storage of cylindrical ice from tap water for medical and laboratory use

- Stainless steel exterior, fully moulded plastic ice collection bin
- **Produces:** 35kg/24hrs
- **Bin store capacity:** 15kg
- **Dimensions:** 870 x 460 x 595mm



HRF229 Cubed Ice Maker Unit 35kg/Day

## Clinell Rediair Instant Air Purifier

### Make poorly ventilated spaces safer - Instant air filtration

Rediair is an instant air purification device, providing clean air where & when you need it. Capturing particulates, odours and 99.995% of airborne pathogens.

At the heart of Rediair is its dual HEPA 14 and carbon filters. These filters capture 10x the particles of a HEPA 13 machine. Adaptable to any situation, Rediair has 4 different operating modes that begin to decontaminate the surrounding air, within seconds. While trapping particles and odours, Rediair was designed to capture airborne pathogens like bacteria, fungi & viral aerosols.

- **10x more effective than HEPA 13** – Two carbon composite HEPA 14 filters work in tandem with the dual centrifugal intake fans to capture particulates, odours and 99.995% of airborne pathogens.
- **High clean air delivery rate** – Despite its small form factor, Rediair has an exceptionally high clean air delivery rate (CADR) of up to 600m<sup>3</sup>/h.
- **Ultra quiet device** – Rediair is surprisingly quiet when in normal use. With its 4 modes of operation, Rediair is designed to decontaminate without causing distraction.
- **Just plug in and turn on** – Rediair starts trapping airborne contaminants right away.
- Built around dual HEPA 14 and carbon cloth composite filters, Rediair begins to decontaminate a room's air almost instantly.

**STR006** Clinell Rediair Air Purifier – Dual HEPA 14 Filters

**STR006.1** Clinell Rediair Dual Replacement Filter Kit

### Rediair filter replacement

Rediair filters will last for around 3000 before indicating to prompt filter replacement. This is roughly 12 months use at 8 hrs a day.

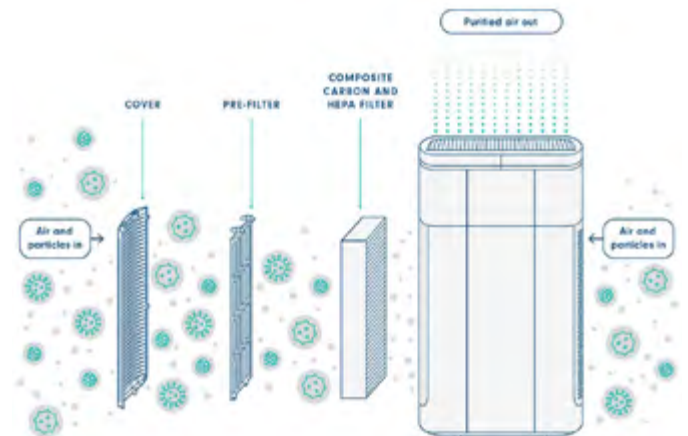

## Grant AP360 Air Purifier

The next generation in air purification, made for medical settings and businesses. Kills 99.95% of known viruses and will recycle the air in a 90m<sup>3</sup> room four times in an hour, maximising air quality and combating the risks of dangerous pathogens.

Innovative design with 360° air intake. Designed to create clean air in more enclosed spaces, together with optimal efficiency.

- Controlled airflow to create clean air in more enclosed spaces
- H13 HEPA filter with UVC lamps captures and destroys 99.95% of viruses and bacteria
- Kills 99.95% of known viruses up to 280 J/m<sup>2</sup> and will recycle the air in a 90m<sup>3</sup> room four times in an hour.
- Ozone free, low power usage for sustainability and cost
- Smooth three speed fan pushes air through a HEPA 13 filter for 360m<sup>3</sup>/hour air processing
- UV chamber damages the DNA and RNA in bacteria & viruses
- Quiet operational mode for minimal noise and disruption

### Details:

- Plug & play no installation needed simply plug in and turn on.
- UV lamp operation indicators to alert when lamp needs replacing or there is a fault.
- Clock & automatic mode with on/off switch.
- Large air processing capacity of 360m<sup>3</sup> /hour.
- Three air flow settings with timer functionality for ease of use.
- Portable design for easy transportation.

**HRS874** Grant AP360 Air Purifier

The next generation in air purification, made for medical settings and businesses. The uv360 kills 99.95% of known viruses and will recycle the air in a 90m<sup>3</sup> room four times in an hour, maximising air quality and combating the risks of dangerous pathogens.

Innovative design with 360° air intake. The uv360 is designed to create clean air in more enclosed spaces, together with optimal efficiency. The air intake system consists of several concentric ducts to extract air in different directions quickly and efficiently.

### Features:

- Controlled airflow to create clean air in more enclosed spaces
- H13 HEPA filter with UVC lamps captures and destroys 99.95% of viruses and bacteria
- The uv360 can kill 99.95% of known viruses up to 280 J/m<sup>2</sup> and will recycle the air in a 90m<sup>3</sup> room four times in an hour.
- Ozone free and low power usage for sustainability and cost efficiency
- Smooth three speed fan pushes air through a HEPA 13 filter for



## Vitalograph asmaPLAN Peak Flow

### Accurate, compact and lightweight Peak Flow Meter

The user-friendly and accurate way to monitor Asthma. Close monitoring of peak flow helps protect quality of life and optimize the efficacy of medication.

- Accurate, lightweight, and portable asthma monitor.
- Robust design.
- Easy to read scale markers.
- Conforms to relevant standards for peak flow meters.
- Suitable for use with Vitalograph Bacterial Viral Filters (BVF's).
- 50-800L/min. measuring range.



**HRS222** Vitalograph asmaPLAN Peak Flow Meter

**HRS106** Vitalograph SafeTway Mouthpieces – 200pk

## Vitalograph MyPEF Peak Flow Meter

Highly accurate, lightweight and portable peak flow meter. Suitable for adults and children. Close monitoring of peak flow helps protect quality of life and optimize the efficacy of medication. For use in clinics, general practice, sports and home.

- Lightweight, pocket size design for convenient portability.
- 50-800L/min. measuring range.
- Accurate 100mm scale – longer than any other PFM's scale.
- Features adjustable 'traffic light' colour coded scale and action plan.
- Conforms to all relevant standards for peak flow meters.
- Includes a robust protective case and integral dust cover for hygiene and protection.
- When used with Bacterial Viral Filters (BVF's) MyPEF is suitable for training purposes involving multi-patient use.



**HRS228** Vitalograph MyPEF Peak Flow Meter

**HRS106** Vitalograph SafeTway Mouthpieces – 200pk

## Vitalograph Lung Monitor

### Fast, accurate lung function monitor for use at home, at work, in primary or secondary care.

Provides accurate and effective monitoring of lung function for respiratory conditions including COPD, cystic fibrosis and post-transplant patients.

Ideal for monitoring at home, work, in clinical trials, in primary or secondary care.

- Measures FEV1, FEV6 and calculates the ratio.
- Large, easy to read display.
- Displays % of personal best FEV1.
- Electronic record – no need for record cards.
- Displays % of personal best FEV1.
- Automatically stores best values in a test session.
- Quality of blow indicator.
- 200 test memory.
- Suitable for multi-subject use in clinic with Vitalograph Bacterial Viral Filters (BVF™).
- CE certified.



**HRS145** Vitalograph Lung Monitor

**HRS286** Vitalograph Eco SafeTway Mouthpieces – 200pk

**HRS106** Vitalograph SafeTway Mouthpieces – 200pk

**HRS106.3** Vitalograph SafeTway Mouthpieces – Child 50pk

**HRS231** Vitalograph Noseclips – 200pk

## Vitalograph Lung Monitor USB

### Fast, accurate lung function monitoring and reporting anytime, anywhere, with USB connectivity.

Provides accurate and effective monitoring of lung function for respiratory conditions including COPD, cystic fibrosis and post-transplant patients.

Ideal for monitoring at home, work, in clinical trials, in primary or secondary care. Links easily to other devices by USB for reporting.

- Measures FEV1, FEV6 and calculates the ratio.
- Displays % of personal best FEV1.
- Automatically stores best values in a test session.
- Quality of blow indicator.
- 200 test memory.
- Suitable for in clinic use with Vitalograph Bacterial Viral Filters (BVF™).
- Large, easy to read display.



**HRS146** Vitalograph Lung Monitor USB

**HRS286** Vitalograph Eco SafeTway Mouthpieces – 200pk

**HRS106** Vitalograph SafeTway Mouthpieces – 200pk

**HRS106.3** Vitalograph SafeTway Mouthpieces – Child 50pk

**HRS231** Vitalograph Noseclips – 200pk

## Vitalograph asma-1 Monitor

The Vitalograph asma-1™ is a lightweight home use electronic respiratory monitor that measures PEF and FEV1. It offers greater accuracy than mechanical peak flow meters and eliminates the need for paper record cards.

Ideal for monitoring at home, work, in clinical trials, in care.

- Measures FEV1 and PEF.
- Electronic record – no need for cards.
- Set unique ‘personal best’ zones.
- Automatically stores best values in a test session.
- Quality of blow indicator.
- 600 test memory.
- Suitable for use in clinic with Vitalograph Bacterial Viral Filters (BVF™).
- Compliant with ATS/ERS 2019 and ISO 23747 / 26782 / 13485
- Large, easy to read display.



HRS141	Vitalograph asma-1 Monitor
HRS286	Vitalograph Eco SafeTway Mouthpieces – 200pk
HRS751	Vitalograph Eco SafeTway Mouthpieces – 50pk
HRS106	Vitalograph SafeTway Mouthpieces – 200pk
HRS106.3	Vitalograph SafeTway Mouthpieces – Child 50pk
HRS231	Vitalograph Noseclips – 200pk

## Vitalograph copd-6 Screener

Identifies those at risk of COPD at the pre-symptomatic stage. The device screens out those whose FEV1 is normal.

The copd-6 screener allows early medical intervention and facilitates better clinical outcomes.

- Monitors COPD patients using their ‘number’, the obstructive index.
- Facilitates ‘case selection’ so that spirometry can be focused on those likely to be diagnosed with COPD.
- Displays FEV1, FEV6, ratio and % predicted, obstructive index, COPD classification and lung age.
- Displays the GOLD COPD classification (stage I – IV) to help recognize the need for a change in the patient’s management plan.
- Built-in quality of blow indicator.
- Suitable for use in clinic with Vitalograph Bacterial Viral Filters (BVF™).
- Large, easy-to-read display.



HRS142	Vitalograph copd-6 COPD Screening Device
HRS286	Vitalograph Eco SafeTway Mouthpieces – 200pk
HRS106	Vitalograph SafeTway Mouthpieces – 200pk
HRS106.3	Vitalograph SafeTway Mouthpieces – Child 50pk
HRS231	Vitalograph Noseclips – 200pk

## Vitalograph copd-6 USB Scener

Identifies those at risk of COPD at the pre-symptomatic stage. Generates reports via USB connection and Vitalograph Reports software. The device screens out those whose FEV1 is normal.

This allows early medical intervention and facilitates better clinical outcomes.

- Monitors COPD patients using their ‘number’, the obstructive index which is based on a percent of predicted.
- Facilitates ‘case selection’ so that spirometry can be focused on those likely to be diagnosed with COPD.
- Screens out anyone with normal FEV1 without the risk of false COPD negatives.
- Displays FEV1, FEV6, ratio and % predicted, obstructive index, COPD classification and lung age.
- Displays the GOLD COPD classification (stage I – IV) to help recognize the need for a change in the patient’s management plan.
- Built-in quality of blow indicator.
- Suitable for use in clinic with Vitalograph Bacterial Viral Filters (BVF™).
- Large, easy-to-read display.



HRS147	Vitalograph copd-6 USB COPD Screening Device
HRS286	Vitalograph Eco SafeTway Mouthpieces – 200pk
HRS106	Vitalograph SafeTway Mouthpieces – 200pk
HRS106.3	Vitalograph SafeTway Mouthpieces – Child 50pk
HRS231	Vitalograph Noseclips – 200pk

## Vitalograph AIM

**Improves inhaler technique for effective drug administration.**

8 out of 10 people use their inhalers incorrectly<sup>1</sup>. The Vitalograph Aerosol Inhalation Monitor is designed to assist medical practitioners in training patients to use their inhaler correctly. Mastery of the correct technique will support more accurate delivery, helping patients get the full benefit of their medication.

The AIM validates good technique in the use of both DPI and MDI inhalers. Using a hygienic, single-use disposable inhaler simulator, AIM provides clear feedback and information to support correct technique including:

- Inspiratory acceleration at start of inspiration
- Timing of firing of MDI
- Inspiratory flow rate throughout inspiration
- Inhalation time within target flow range
- Breath-hold time at end of inhalation

<sup>1</sup>d’Ancona, G., & Weinman, J. (2021). Improving adherence in chronic airways disease: are we doing it wrongly? *Breathe (England)*, 17(2), 210022. DOI: 10.1183/20734735.0022-2021



HRS705.1	Vitalograph AIM (Includes x1 Placebo, x5 MDI and x5 DPI)
HRS705.2	Vitalograph Disposable DPI Inhaler Simulator – 25pk
HRS705.3	Vitalograph Disposable MDI Simulator – 25pk
HRS705.5	Placebo Canisters – 8pk

## Vitalograph Pneumotrac Spirometer with Spirotrac 6 Software



The next generation Pneumotrac™ Spirometer combined with our new and improved Spirotrac® software is a powerful and flexible respiratory diagnostic device. Improved sleek design with no moving parts for optimal robustness. With a reduced footprint spirometry testing can take place anywhere near a PC/tablet.

Suitable for testing both adults and paediatrics due to the extremely reliable Fleisch flow technology which is accurate even at very low flow rates.

Compliant with the 2019 ATS/ERS spirometry update, ensuring your service meets international guidelines on accuracy and reporting. Spirotrac 6 features a brand-new intuitive interface with advanced quality control feedback for rapid and easy testing. Vitalograph Connect middleware software is included, connecting to all major EHR/EMR systems via HL7 and GDT.

- Meets 2019 ATS/ERS standardisation of spirometry update.
- Supports Full Feature Spirometry Testing and Bronchodilator Responsiveness Testing with over 50 available parameters.
- Highly accurate, robust, and stable flow-measuring tech.
- Lowest running costs & environmentally friendly; no need for costly disposable sensors, turbines, or flow tubes.
- Save time & money on cleaning using Vitalograph Bacterial Viral Filters with validated cross-contamination efficiency >99.999%, protecting the device, patient, and operator.
- Real-time curves and all new incentive animations encourage optimal subject performance.
- Instant quality feedback using the latest test/session acceptability, usability and repeatability criteria
- Automatic computer interpretation based on ATS/ERS & GOLD standards.
- Fast evaluation of results using latest GLI spirometry predicted equations with LLN, %Pred and Z-scores. Other predicted equations are selectable.
- Ensuring best practice with quick and easy calibration verification routines recommended by 2019 ATS/ERS spirometry guidelines.
- Automatic BTPS correction with built-in temperature sensor for optimal accuracy.
- Share test data easily with compatible Electronic Medical Record (EMR) systems through HL7.

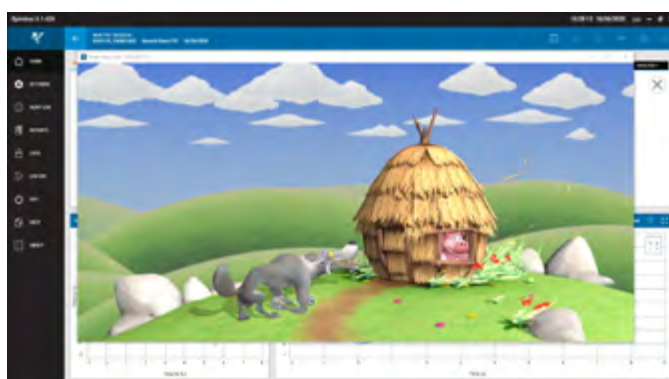

**HRS201.1** Vitalograph Pneumotrac Spirometer with Spirotrac 6 Software

**HRS041.1** Vitalograph 3L Precision Syringe

**HRS750** Vitalograph Eco BVF with Bite Lip – 100pk

**HRS760** Vitalograph Eco BVF with Bite Lip – 75pk

**HRS759** Vitalograph Eco BVF with Bite Lip & Disposable Nose Clip – 75pk

**HRS760.1** Vitalograph Eco BVF and Disposable Nose Clip – 80pk

**HRS042** Vitalograph BVF Bacterial Viral Filters – 50pk

## Vitalograph SafeTway Mouthpieces

Suitable for use with spirometers from Vitalograph, Micro Medical, MIR, Cosmed, Clement Clarke & Peak Flow Meters. For expiratory only spirometry testing

### ECO SafeTway Mouthpieces

Recyclable SafeTways, the best choice for one-way valve mouthpieces

80% less energy to make  
100% recyclable plastic  
57% reduction in weight



**HRS286** Vitalograph Eco SafeTway Mouthpieces – 200pk

**HRS751** Vitalograph Eco SafeTway Mouthpieces – 50pk

**HRS106** Vitalograph SafeTway Mouthpieces – 200pk

**HRS106.3** Vitalograph SafeTway Mouthpieces – Child 50pk

## Vitalograph BVF™ Bacterial Viral Filters

Protects patients, medical personnel and equipment from cross infection and contamination during pulmonary function testing.

Eco BVFs combine independently validated 99.999% bacterial and viral cross-contamination efficiency, with a reduced environmental impact as less plastic used in manufacturing.

- Validated cross-contamination efficiency >99.999%.
- Proven efficiency at flow rates in excess of ERS high expiratory flow recommendations.
- Traps expectorated matter, bacteria and viruses.
- Reduces device cleaning, saving time.
- 80% reduction in energy expended during manufacturing\*
- 54% reduction in filter waste volume\*

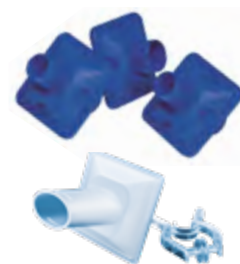

\*Compared to standard BVF

**HRS759** Vitalograph Eco BVF with Bite Lip & Disposable Nose Clip – 75pk

**HRS760** Vitalograph Eco BVF with Bite Lip – 75pk

**HRS042** Vitalograph BVF Bacterial Viral Filters – 50pk



## Vitalograph Alpha Spirometer



### The next generation of diagnostic desktop spirometers

Designed for testing on the go, remotely or in a clinic, the Alpha is our ultimate desktop spirometry solution.

The new Alpha encompasses compliance with the ATS/ERS 2019 spirometry guidelines, multiple testing options, quick loading integrated thermal printer and direct links to Vitalograph Device Studio to generate PDF reports. Vitalograph Connect provides versatile connectivity to your electronic medical records via HL-7 and GDT, taking spirometry testing to the next level. Features a 7" high-resolution touchscreen and a redesigned intuitive user-friendly interface.

- Meets 2019 ATS/ERS standardization of spirometry update.
- Supports full feature Spirometry Testing and Bronchodilator Responsiveness Testing with over 50 available parameters.
- Utilising proven, highly accurate, robust, and stable flow measuring technology.
- Save time & money on cleaning using Vitalograph BVFs with validated cross-contamination efficiency >99.999%, protecting the device, patient, and operator.
- Fast integral thermal printer – No PC required.

- Automatic interpretation based on ATS/ERS & GOLD standards.
- Instant quality feedback using the latest test/session acceptability, usability and repeatability criteria.
- Lowest running costs & environmentally friendly: no need for costly disposable sensors, turbines, spirettes or flow tubes.
- Ensure accurate results with quick and easy calibration verification routines recommended by 2019 ATS/ERS spirometry guidelines.
- Fast evaluation of results using latest GLI spirometry predicted equations with LLN, %Pred and Z-scores. Other predicted equations are selectable.
- Direct connectivity with Vitalograph Device Studio to generate PDF reports and receive the latest firmware updates.
- Share test data easily with compatible Electronic Health Records (EHR) and Electronic Medical Records (EMR) systems through HL7, GDT.

**HRS140** Vitalograph Alpha Spirometer with Device Studio and Connect Software

**HRS041.1** Vitalograph 3L Precision Syringe

**HRS750** Vitalograph Eco BVF with Bite Lip – 100pk

**HRS760** Vitalograph Eco BVF with Bite Lip – 75pk

**HRS759** Vitalograph Eco BVF with Bite Lip & Disposable Nose Clip – 75pk

**HRS760.1** Vitalograph Eco BVF and Disposable Nose Clip – 80pk

**HRS042** Vitalograph BVF Bacterial Viral Filters – 50pk

**HRS231** Vitalograph Noseclips – 200pk



## Vitalograph Micro Spirometer



A versatile handheld respiratory diagnostics solution that delivers detailed spirometry testing, in a range of environments.

Ideal for multiple subject testing scenarios, the micro has paperless reporting and includes Device Studio for creating full PDF reports, along with USB and Bluetooth connectivity.

- Features advanced flowhead technology offering high-quality spirometry testing that's accurate, repeatable, easy and safe.
- ATS/ERS 2019 accuracy compliant.
- Fast evaluation of results with %Predicted comparison, LLN and Z scores. Latest GLI predicted sets.
- Customisable PDF reports and 325 test subject memory.
- Clear and instant test results with 2.8" capacitive touchscreen and high-end graphics.
- Optional detachable flowhead makes it easier to view data during test and is an effective option for improving hygiene through creation of distance between subject and tester.
- Bluetooth connectivity for effortless communication with other devices and healthcare monitoring apps.

**HRS035** Vitalograph Micro Spirometer

**HRS231** Vitalograph Noseclips – 200pk

**HRS231** Vitalograph Noseclips – 200pk

**HRS231** Vitalograph Noseclips – 200pk

**HRS042** Vitalograph BVF Bacterial Viral Filters – 50pk



## Vitalograph In2itive Spirometer

The Vitalograph In2itive was created for healthcare professionals that need spirometry in a smaller, portable but powerful package. The In2itive is a handheld spirometry solution that uniquely solves this with high-performance spirometry on the move compliant to ATS/ERS 2019 guidelines for accuracy and test quality with direct wireless EMR connectivity as standard.

- Meets 2019 ATS/ERS standardization of spirometry update ensuring that testing meets the most up-to-date, internationally recognised guidelines.
- The updated test quality grading system and live testing prompts give you the power to get the best quality results possible.
- Supports Full Feature Spirometry Testing and Bronchodilator Responsiveness Testing for comprehensive testing wherever you go.
- Quickly evaluate results using GLI predicted equations with LLN, %Pred and Z-scores.
- Highly accurate, robust and stable flow measuring technology gives peace of mind for accurate results.
- Low running costs: no need for costly disposable sensors, turbines, spirettes or flow tubes.
- Automatic interpretation based on ATS/ERS & GOLD standards.



**HRS264** Vitalograph In2itive with Vitalograph Reports Software

**HRS262** Vitalograph In2itive with Spirotrac® 6 software

## FeNO by NIOX

By accurately assessing airway inflammation, FeNO testing can help improve asthma patient outcomes in one simple test.

- Accurately assess airway inflammation at the point-of-care.
- NIOX® protects your patients from failing a test. Flow Rate Control™ guides your patients to a successful test, leading to an accurate result each time, every time.
- Designed to make FeNO testing as simple as inhaling and exhaling. Help diagnose patients, optimise treatment, reduce exacerbations, uncover non-adherence to Inhaled Corticosteroids (ICS), all in one breath.
- FeNO levels are interpreted worldwide with cut-off points from ATS guidelines. Those cut-off points were derived from studies where 83% of patients used NIOX® technology.
- NIOX® is trusted by clinical researchers across the globe and has participated in thousands of trials, including pivotal studies for asthma biologics.
- Excellent repeatability and reproducibility, enabling a successful measurement in a single test. With unique technology to guarantee an accurate result every time.
- The only device in Europe and US that is fully compliant with ERS and ATS recommendations for FeNO.



**HRS015** NIOX VERO® device with Sensor for 100 tests and 100 filters

**HRS015.1** NIOX VERO® device with Sensor for 300 tests and 300 filters

**HRS015.2** NIOX VERO® device with Sensor for 500 tests and 500 filters

## Vitalograph Noseclips

Vitalograph disposable nose clips are comfortable to wear and save time & money by eliminating cleaning.



**HRS231** Vitalograph Noseclips – 200pk

## Vitalograph Precision Syringes

Provide quick and easy accuracy checks with reliability and fast verification. The 3L precision syringe can be used with flow or volume sensor systems and is compatible with any manufacturers' equipment. Each syringe has accuracy certified to better than 0.5%.

Use of a precision syringe is recommended for all spirometers as required by ISO 26782:2009.



**HRS041** Vitalograph 1L Precision Syringe

**HRS041.1** Vitalograph 3L Precision Syringe

## AioCare Spirometer

A professional system to monitor and treat pulmonary diseases, consisting of a portable hospital-grade spirometer connected to a smartphone app and an online panel to access the results.

The device enables a full spirometry test to be conducted, including a bronchial challenge workflow. If required, AioCare may be used for patients at home.

### Breakthrough in diagnostics of patients with asthma/ COPD

- Small, portable device that can be taken anywhere.
- Two dedicated apps for doctor and patient.
- Simple interface for creating records and insights enabling statistical analysis and management of history/trending.
- Automatic environmental conditions adaption (BTPS).
- Integrated SpO2/HR measurement.
- Calibration free. Be ready for spirometry at any time.
- GDPR compliant. Keep control of the usage of your data.
- Transmitted data is secured by the SSL protocol. Data is entirely stored in the certified Microsoft Azure cloud.

**HRS003** Spirometer Doctors Unit +12 Month Software

**HRS003.1** AioCare Doctor 12 Month Software (Year 1)

**HRS003.2** AioCare Spirometer - Patient Unit

**HRS003.3** AioCare Dr/Patient Replacement Base (Tube Holder)

**HRS003.4** AioCare Doctor/Patient Replacement Tube

- Buy the device and download the app to your phone or tablet.
- Create a patient's record and enter their data
- Pair the device and perform the spirometry test/ screening
- Results immediately available on your phone or computer



## SleepCube CPAP with SmartFlex

DeVilbiss SleepCube range of Standard and Auto Plus with both utilising SmartFlex expiratory relief comfort feature

- Smallest surface of CPAP with heated humidification system
- Includes SmartFlex which reduces the pressure when the patient is exhaling to aide patient comfort
- Among the quietest CPAPs on the market – only 26 dBA
- Introduction to CPAP therapy and instructional video included
- Patient air tubing extends from the back for aesthetics
- Large slip-resistant pads on bottom of unit for stability
- CPAP can run from a 12V DC source (not heated humidifier) and will switch automatically to AC power if available
- Included in every SleepCube is the SmartCode data compliance feature which encodes usage data into a code that can be easily decrypted using free software
- Large backlit LCD and easy to follow patient menu
- Delay pressure ramp eases to the prescribed pressure
- Extra air inlet and fine particle filter included



The **SleepCube Standard Plus** is a fixed pressure CPAP with SmartFlex expiratory relief comfort feature designed for the effective treatment of Obstructive Sleep Apnoea.

The **SleepCube Auto Plus** is an auto adjusting PAP device with SmartFlex expiratory relief comfort feature.

**HRS188** SleepCube CPAP Standard Plus with Smartflex

**HRS189** SleepCube CPAP Auto Plus with Smartflex

**HRS190** Heated Humidifier

## In-Check™ Nasal

Measures peak nasal inspiratory flow through the nasal passages; providing information of nasal obstruction. Objective measurement of nasal obstruction for diagnostic uses.

- Measures nasal inspiratory flow between 30–370 L/min
- Judge the degree of obstruction in the nasal airway
- Helps assess the benefits of therapeutic intervention by providing an objective assessment of nasal airway patency
- Supplied with medium mask, small masks are available
- Re-usable masks are also available

**HRS753** In-Check with Medium Mask

**HRS755** Medium Mask (Single patient use)

**HRS753.1** PNIF Anti-bacterial Filter



## MicroCO Monitor

Provides accuracy and simplicity in CO breath testing. Some of its many features include, fast response time, 1ppm resolution, immediate display of CO levels in PPM and %COHB, colour light indicators, capable of interfacing with COBRA™ software (please enquire for more details)

- Designed for use in smoking cessation programmes
- Also used for CO poisoning / smoke inhalation screening
- Measures carbon monoxide in PPM and % COHb
- COBRA Windows software available (please enquire)
- Small, very lightweight and easily portable
- Breath hold timer for an accurate assessment
- Very simple device that is easy to use, cleaned and maintain
- Calibration kit available

<b>HRS046</b>	MicroCO Monitor
<b>HRS860</b>	Calibration Kit for CO Monitors (Gas & Regulator)
<b>HRS861</b>	MicroCO and Smokecheck Mouthpieces – 250pk
<b>HRS863</b>	Micro Medical CO Calibration Gas (replacement gas) 20L



## Micro I™ Pocket Spirometer

Designed specifically for situations where low cost precision spirometry measurements are required, the Micro I™ is extremely lightweight and portable making it suitable for remote testing.

The backlit graphical display and touch sensitive keypad, ensure ease of use and functionality, combined with a rechargeable battery for remote use in this ergonomically designed spirometer.

- Choice of up to 9 indices recorded & choice of predicted value
- Results can be configured and displayed as a % of predicted, standard deviation (SD) or z Scores
- Measurements: FEV1, FEV6, FVC, FEV1/FEV6, FEV1/FVC, PEF, FEF25-75, FEF75, FEF25 ATS/ERS
- Quality prompt for each manoeuvre
- **Dimensions:** 162x61x30mm
- **Weight:** 152g



**HRS703** Micro I™ Pocket Spirometer

## PulmoLife COPD Screening Tool

**What is it for?**

- Quick, simple COPD screening in adult smokers
- Perfect for the Doctor's room/bag deciding if full spirometry is required
- Encouraging patients to stop smoking

**What results does it give?**

- FEV1 – the measurement of choice in COPD screening
- % Predicted FEV1 – how the FEV1 compares to normal values
- Lung Age – meaningful and powerful information for the patient
- Visual image of a smoker - helps the patient realise the physical damage caused by smoking



**HRS255** PulmoLife COPD Screening Tool

## Bedfont piCO Smokerlyzer®

An essential tool used by stop smoking clinics and health advisors in order to help motivate smokers to quit the habit. The device analyses a breath sample and displays results to the user.

- Clear colour graphics and simple interface for complete ease of use
- Perform a test in seconds with easy to follow prompts on-screen
- Visual way to easily interpret test results with traffic light symbols
- USB connectivity to PC using COdata+
- Built with SteriTouch®, bacteria is killed on contact minimising infection risk



<b>HRS108</b>	Bedfont piCO Smokerlyzer®
<b>HRS110.1</b>	Steribreath ECO Mouthpieces – 200pk
<b>HRS108.5</b>	D-Pieces for Bedfont Smokerlyzers Pack – 12pk

## Bedfont piCO Baby Smokerlyzer®

A breath carbon monoxide monitor, specifically designed for use with pregnant smokers. It is a valuable tool for pregnant smokers to visualise the effects of smoking on them and their child.

- Measures ppm, %COHb with automatic conversion to %FCOhb (foetal carboxyhaemoglobin)
- Clear colour graphics and simple interface for complete ease of use
- Perform a test in seconds with easy to follow prompts on-screen
- Traffic light results indicator
- USB connectivity to PC using COdata+



<b>HRS109</b>	Baby Bedfont Scientific piCO Baby Smokerlyzer
<b>HRS110.1</b>	Steribreath ECO Mouthpieces – 200pk
<b>HRS108.5</b>	D-Pieces for Bedfont Smokerlyzers Pack – 12pk

# Precise medical weighing, from the market leader



seca 959

EMR-validated chair scale with precise graduation



seca 704

EMR-validated column scale with 300 kg capacity



seca 877

Flat scale with Mother+child function



Image contains optional portable stadiometer seca 217



## seca Scale-up Line

### Price includes Initial Calibration & Verification with Certificate

Developed for electronic medical records – We're not only concerned with the perfect integration of measured data into your EMR, we also deliver the ideal measuring station. These scales offering rapid measurement in just seconds, plus an extremely resistant glass platform offering a capacity of 300kg. Transportation is simple with rubber wheels to rear of base.

The ID-Display lets you see which patient was recorded with the scanner to prevent any confusion. That means more control for you when transferring to the Electronic Medical Records (EMR) and significantly improved safety for users and patients.

- The display shows names or IDs of users and patients
- Display-controlled data transfer
- Voice response for patient guidance aids personnel
- Rapid measurement process within seconds thanks to the innovative ultrasound technology
- Elegant design featuring extreme robustness thanks to a steel handrail directly anchored to the cast iron base
- Large platform made of seca Bearclaw Glass® virtually break-resistant glass for extreme durability and hygiene
- Footprint LED lights show the patient the correct position for height measurement.
- Convenient transport with extremely robust rubber wheels.
- **Calibration class:** III
- **Capacity:** 300 kg
- **Graduation:** 50 g < 150 kg > 100 g
- **Display type:** 4.3" tilttable and rotatable touchscreen
- **Interfaces:** WiFi, Ethernet
- **Measuring range:** 60 – 220 cm
- **Graduation of measuring range:** 1 mm



<b>HSC898</b>	Handrail scale with ID-Display
<b>HSC899</b>	Ultrasonic measuring station with ID-Display
<b>HSC897</b>	Ultrasonic measuring station with ID-Display and handrail

## seca 287 Ultrasonic Measuring Station

### Price includes Initial Calibration & Verification with Certificate

Voice guidance can be optionally selected and there is a sticker directly on the measuring station that illustrates the correct stance and posture. This makes it easy for the patient to use without any assistance from the nursing staff. This station also features a touchscreen display keylock function for accuracy.

- Three pairs of sensors and constant auto-calibration ensure the most precise results
- The digital evaluation algorithm eliminates imprecision for the highest measurement accuracy
- A wide variety of output options for the measurement results
- **Approval class:** III
- **Capacity:** 300 kg
- **Graduation:** 50 g < 150 kg > 100 g
- **Measuring range:** 60 – 210 cm
- **Measure:** 434 x 2.270 x 466 mm
- **Net weight:** 15.6 kg

Weight, Height, BMI and Patient/Self Measurement with voice guidance.

**Fully integrates with EMIS, TPP SystemOne and Vision EMR systems, saving time and increasing patient safety. Contact us for more details.**



<b>HSC099</b>	seca 287 Ultrasonic Measuring Station
<b>HSC099.1</b>	seca 287DP direct print software & seca 456 usb receiver

## seca 487 Animal Sticker

Your seca measuring station will immediately become more child-friendly, and the weighing and measuring of young patients will be quick and easy. A different animal is affixed at eye level depending on the height of the child. Measurement can be taken while they focus on the raccoons, lions and co. Child's head will be quickly positioned for precise height measurement.

- Colorful animals make measuring stations more child-friendly
- Animal figures at eye-level help obtain a correct head position for height measurement
- Quality self-adhesive sticker stays colourful for a long time
- Approved medical device: resistant to disinfectants
- Suitable for the seca 287 ultrasonic measuring station and seca Scale-up Line

**HSC099.2** seca 487 Animal sticker for measuring stations



## seca mBCA 525

The seca mBCA 525 is one of a kind in terms of function and performance. The unique measuring mat measures all of the required parameters such as fat mass, muscle mass and body water in a fully self-sufficient way. The short cables simplify working. The mat is also automatically linked to the touchscreen monitor by Wi-Fi, which can also be deactivated if required.

The large memory of the monitor has sufficient capacity for over 100,000 measurements. This enables a large number of patients and courses of therapy to be reliably documented for years. Furthermore, measurements can be reliably carried out regardless of location in hospitals or in private practices.

In brief, the seca mBCA is the best help for diagnosis of many diseases such as of obesity, diabetes or malnutrition

- **Precise:** proven by international medical studies
- **Fast:** measurements executed in 17 seconds
- **Power supply:** Rechargeable batteries, Power adapter
- **Measure:** 252 x 262 x 230 mm / Net weight: 3 kg
- **Measure method:** 8-point Bio-electrical Impedance Analysis
- **Measurement time:** Maximum of 30 seconds

**HSC100** seca mBCA 525



## seca 899 Class III Approved Scale

**Price includes Initial Calibration & Verification with Certificate**  
Remote display scale, recommended by the Child Growth Foundation for the National Child Measurement Programme. Lightweight and mobile with carrying handle. Remote display ideal for desk, wall mounting or handheld (for discreet weighing)

- BMI (Body Mass Index) calculation
- Stable low-level base
- Automatic power down and long-life battery operation
- Capacity: 200 kg
- Graduation: 100g < 150 kg > 200 g
- Dimensions: 315 x 58 x 313 mm
- Weight: 4.2 kg
- CE marked approval class III

**HSC071** seca 899 Class III Approved Scale

**HSC069** seca 421 Carry Case

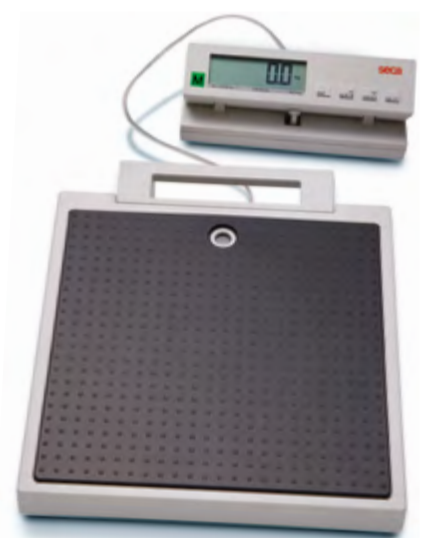

## seca 285 Wireless Measuring Station

**Price includes Initial Calibration & Verification with Certificate**

Weighing and measuring in one step is made possible by the seca 285. The scale features high weighing capacity, a heel positioner and a solid headpiece with integrated seca Frankfurt Line for precise positioning of the patient's head.

Moreover, the complete measuring station has two displays. One display is for direct read-out of height from the headpiece and the other is a three-line multi-function touch display for simultaneous display of height, weight and BMI. Moreover, the scale shows the slightest weight changes with its fine 50-gram graduation and transmits all measurements via the seca 360° wireless.

**Fully integrates with EMIS, TPP SystemOne and Vision EMR systems, saving time and increasing patient safety.**

- Network-capable with seca 360° wireless technology
- Frankfurt Line for precise positioning of head
- Fine 50-gram graduation and high capacity of up to 300 kg
- Large height measurement range from 30 to 220 cm
- The three-line multi-function touch display shows weight, height and the automatically calculated BMI

### Scale Specification

- Capacity: 300 kg
- Graduation: 50 g < 150 kg > 100 g
- Dimensions: 440 x 2.400 x 470 mm
- Platform dimensions: 440 x 60 x 470 mm
- Weight of scales: 16 kg
- Data transmission: seca 360° wireless
- Functions: auto/HOLD, auto-BMI, clear, other/child, weighing range switch-over
- Calibration Class: III (3)

**HSC111.1** seca 285 Wireless Measuring Station



## seca 635 Bariatric Platform Scale

**Price includes Initial Calibration & Verification with Certificate**

As the obesity rate continues to rise, it's important to have a scale that can accommodate patients of all shapes and sizes. The seca 635 personal scale is the recommended choice.

It has a very large, flat platform and an increased weighing capacity, which is necessary to accommodate overweight patient or individuals affected by obesity.

The seca 635 is designed to perform heavy work for years and withstand the highest loads.

- Functions: damping / HOLD / BMI / Automatic switch-off / Upper limit value / TARE / Pre-TARE
- Capacity: 300kg
- Graduation: 100g < 200kg > 200g
- CE marked approval class III
- Dimensions: 640 x 55 x 600mm
- Platform dimensions: 560 x 55 x 560mm
- Cable length: 2.3m
- Weight: 14.4kg

**HSC070** seca 635 Bariatric Platform Scale

**HSC867** seca 635R Bariatric Platform Scale with RS232 interface





## seca 878dr Class III Approved Scale

**Price includes Initial Calibration & Verification with Certificate**

The doctor scale seca 878dr is specially designed for use in medical practices. Equipped with an LCD display, the foot switch makes this flat scale an ideal tool for any medical facility.

- Designed for medical practices with impressive long service life
- Robust quality production with an innovative design Double facing display for ease of reading from various positions
- Customised label for personalisation such as clinicians, the practices' or departments name available
- Resistant to NHS cleaning agents, including Clinell
- Capacity: 200 kg
- Graduation: 100 g < 150 kg > 200 g
- Dimensions: 321 x 61 x 361 mm
- Platform dimensions: 288 x 60 x 280 mm
- Weight: 4.1 kg

**seca**



**HSC494** seca 878dr Class III Approved Scale

**HSC073** seca 415 Carry Case

## seca 875 class III Approved Scale

**Price includes Initial Calibration & Verification with Certificate**

In the seca 875 you've found the right solution if you're looking for a lightweight scale that's stable, compact and easy to clean. Features an easy to clean slip-resistant base, a clear easy to read LCD display and long battery life.

- Extra long life battery operation
- Capacity: 200kg
- Graduation: 200g
- Dimensions: 321 x 60 x 356mm
- Dimensions platform: 288 x 60 x 278 mm
- Weight: 3.9kg
- CE approval class III
- Can be integrated (via seca 437 adaptor) with the seca 217 to provide a complete measuring and weighing station.

**seca**



**HSC080** seca 875 class III Approved Scale

**HSC073** seca 415 Carry Case

## seca 877 Class III Approved Scale

**Price includes Initial Calibration & Verification with Certificate**

Lightweight, fully portable scales with multiple features and functions that make this a versatile low-level scale.

- Touch start with automatic power-down
- 2 in 1 (mother and child weighing function)
- Automatic power down
- Extra long-life battery operation
- Capacity: 200 kg
- Graduation: 100 g < 150 kg > 200 g
- Dimensions (WxHxD): 315 x 58 x 313 mm
- Weight: 3.9 kg

**seca**

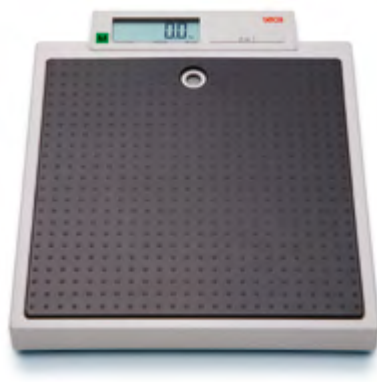

**HSC068** seca 877 Class III Approved Scale

**HSC073** seca 415 Carry Case

## seca 711 Class III Approved Mech. Scale

**Price includes Initial Calibration & Verification with Certificate**

- Extra high capacity of 220 Kg
- Large, low platform
- Simple to operate and easy to read due to eye-level read out
- Sturdy construction with cast-iron base
- Capacity: 220 Kg
- Graduation: 100g
- Dimensions : 520 x 1,556 x 520 mm
- Platform: 350 x 84 x 360 mm
- Weight: 23.5 kg
- Optional Measuring rod: seca 220
- CE marked approval class III

**seca**



**HSC037** seca 711 Class III Approved Scale with Eye level beam

## seca 856 Digital Organ & Nappy Scale

- High reliability with protected electronics
- Reliable weight determination
- Easy to clean
- Resistant to NHS cleaning agents, including Clinell
- Energy-saving automatic switch-off
- Capacity: 5.000 g / 11 lbs
- Graduation: 1 g < 3,000 g > 2 g / 0,05 oz < 6,6 lbs > 0,1 oz
- Dimensions (WxHxD): 266 x 53 x 266 mm
- Weight: 1.9 kg / 4.2 lbs
- Power supply: Batteries
- Functions: Automatic switch-off, Pre-TARE, TARE, HOLD, kg / lbs switch-over
- Material: Cover - stainless steel / base - black plastic material



**HSC101** seca 856 Organ & Nappy Scale with Stainless Steel Cover

## DS-502 Class III Organ & Theatre Scale

- High reliability with protected electronics
- Reliable weight determination
- Easy to clean
- Resistant to NHS cleaning agents, including Clinell
- Energy-saving automatic switch-off
- Capacity: 5.000 g / 11 lbs
- Graduation: 1 g < 3,000 g > 2 g / 0,05 oz < 6,6 lbs > 0,1 oz
- Dimensions (WxHxD): 266 x 53 x 266 mm
- Weight: 1.9 kg / 4.2 lbs
- Power supply: Batteries
- Functions: Automatic switch-off, Pre-TARE, TARE, HOLD, kg / lbs switch-over
- Material: Cover - stainless steel / base - black plastic material



**HSC047** DS-502 Class III Organ & Theatre Scale

## seca 336i Wireless Baby Scale

**Price includes Initial Calibration & Verification with Certificate**

The seca 336i impresses users with wireless transmission of weight and height into an Electronic Medical Record (EMR) system. Fully integrates with EMIS, TPP SystemOne and Vision EMR systems, saving time and increasing patient safety. Contact us for more details.

- Capacity: 20 kg
- Graduation: 5 g < 10 kg > 10 g
- Functions: TARE, BMIF, D, Auto-HOLD, auto weighing range switch-over, damping, automatic switch-off, SEND/PRINT, Confirm, Wi-Fi
- **USB barcode scanner not supplied**
- Measuring rods available separately



**HSC891** seca 336i Baby scale

**HSC892** seca 234 Digital measuring rod

**HSC893** seca 232n analogue measuring rod

**HSC400** seca 400 Power Adapter

## seca 336 Class III Approved Baby Scale

**Price includes Initial Calibration & Verification with Certificate**

Has all that is necessary to make daily routine in the surgery and hospital so much easier in future: as this scale is not only easy to use but also mobile and durable.

- Low profile generous and comfortable weighing tray
- Lightweight, with in-built handle and clear LCD display
- Weight hold and tare features
- Long life battery (mains adaptor optional)
- Capacity: 20kg
- Graduation: 5 g < 10 kg > 10 g
- Dimensions: 640 x 105 x 300mm
- CE marked approval class III



**HSC039** seca 336 Class III Approved Baby Scale

**HSC893** seca 232n analogue measuring rod

**HSC400** seca 400 Power Adapter

# Professional medical scales for users, feel-good scales for babies



## seca 336

Baby scale with flat weighing tray and optional measuring rod

- + Measuring and weighing can be done in a single step thanks to an optional length measuring rod
- + Flat construction for easy storage in drawers
- + Wide range of functions: TARE, BMIF, HOLD, Auto-HOLD and adjustable damping
- + Easy-to-read, backlit LCD display
- + Optional with digital measuring rod seca 234 or analog measuring rod seca 232 n



## seca 376

Baby scale with extra large weighing tray

- + Weighing tray with high side walls for increased safety
- + Weighing and measuring in one step thanks to optional length measuring rod
- + Three-step damping for fast weighing
- + Large tray is suitable for weighing toddlers while sitting
- + Medical-grade seca scale technology with precise graduation



## seca 761 Class III Approved Scale

Price includes Initial Calibration & Verification with Certificate

This seca classic has greatly influenced the image of scales. With an absolutely precise dial, synthetic covering used in medical applications, and steel plate housing from the good old days. For one thing a classic should never be boring.

- Total Capacity: 150kg with 1kg graduations
- Dimensions: 300 x 105 x 460mm
- Weight: 4kg
- CE marked approval class III
- Not suitable for use in hospitals



HSC018.C3 seca 761 Class III Approved Scale

## seca 799 Class III Approved Scale

Price includes Initial Calibration & Verification with Certificate

- New technology digital column scale
- Low level non-slip platform
- BMI (Body Mass Index) calculation
- Convenient HOLD and TARE features
- Automatic power-down
- Long-life battery operation
- Optional height measure seca 220
- CE marked approval class III
- Graduation: 100 g < 150 kg > 200 g
- Dimensions: 292 x 830 x 390 mm
- Capacity: 200 kg
- Weight: 6.8 kg



HSC072 seca 799 Class III Approved Scale

HSC027 seca 220 Scale Mounted Height Measure

## seca 704 Class III Approved Digital Scale

Price includes Initial Calibration & Verification with Certificate

Column scales with wireless data transmission, a BMI function and a high capacity of up to 300 kilograms. From the weighing of small children to obese patients – the seca 704 can do it all.

There are two options: integrate a mechanical measuring rod or receive data wirelessly from a separate digital stadiometer.

Fully integrates with EMIS, TPP SystemOne and Vision EMR systems, saving time and increasing patient safety. Contact us for more details.

- Very high capacity of 300 Kg
- Stable safe footing on enlarged platform
- Checking the nutritional condition of a patient with integrated BMI function
- Provides up to 16,000 weighings from just one set of batteries (mains adaptor optional)
- Comfortable weighing due to TARE and HOLD functions
- Graduation: 50g < 150kg > 100g
- Dimensions : 360 x 930 x 520 mm
- Platform : 350 x 84 x 360 mm
- Weight: 16 Kg
- Optional Measuring rod: seca 220
- Power supply: Batteries / power adapter (optional)
- CE marked approval Class III

HSC059 seca 704 With very high capacity

HSC059.1 seca 704r Class III Digital column scale & RS232 Interface

HSC027 seca 220 Scale Mounted Height Measure



## seca 757 Class III Wireless Baby Scale

**Price includes Initial Calibration & Verification with Certificate**

- Highly precise SCBU/Neo Natal Scale
- Wireless connectivity included
- Resistant to NHS cleaning agents, including Clinell
- Integrated RS232 interface
- Electronic scale with digital display face
- Capacity: 15 kg
- Graduation Weight: 2g
- Power supply: Power Adaptor / Rechargeable Battery
- Weight: 7.1 kg
- Dimensions: 551 x 151 x 320 mm

**Fully integrates with EMIS, TPP SystemOne and Vision EMR systems, saving time and increasing patient safety. Contact us for more details.**

**seca**



systemone

emis

vision



**HSC050** seca 757 Class III Wireless Baby Scale

## seca 402 Baby Scale Trolley

- Custom-made indentations in the surface hold seca baby scales firmly in place. (See image below)
- Strong, robust trolley frame
- Ideal working height of 80 cm
- Dimensions: 715 x 800 x 435 mm
- Weight: 11.5 kg
- Max. load: 100 kg
- 4 bumpers
- 2 brakes
- Optional: paper roll holder

**seca**



**HSC051** seca 402 Baby Scale Trolley (Trolley only)

## seca 384/385 Class III infant Scale

**Price includes Initial Calibration & Verification with Certificate**

384 is a Portable Baby scale and Toddler floor scale combined with easily detachable baby tray with a 20kg capacity TARE, HOLD and BREAST MILK INTAKE functions.

385 is a Portable Baby scale and Child floor scale combined with easily detachable baby tray with a 50kg capacity TARE, HOLD and BREAST MILK INTAKE functions and weighing range switch over ideal for GP Clinics/Community Midwives.

- Lightweight and portable
- Resistant to NHS cleaning agents, including Clinell
- Power saving operation can provide 20,000 weighs per set
- Dimensions: 550 x 165 x 330mm
- Weight: 2.5kg

**seca**



**HSC079** seca 384 Class III Approved Portable Baby Scale – 20kg max

**HSC078** seca 385 Class III Approved Portable Baby Scale – 50kg max

**HSC067** seca 413 Portable Toddler Carry Case

**HSC067.1** seca 431 Backpack

## seca 376 Class III Wireless Baby Scale

**Price includes Initial Calibration & Verification with Certificate**

- Shell-shaped for increased comfort and safety
- Extra large tray for problem-free weighings
- Mobile with power saving battery operation
- Functions: TARE, HOLD
- Capacity: 20Kg
- Graduation: 5g < 7.5Kg > 10g
- Dimensions: 620 x 190 x 358 mm
- Weight: 3.2 Kg
- Power Supply: Batteries (mains adapter optional)
- CE marked approval Class III
- Functions: TARE, BMIF, HOLD, auto-HOLD, weighing range switch-over, adjustable damping, automatic switch-off

**Fully integrates with EMIS, TPP SystemOne and Vision EMR systems. Contact us for more details.**

**seca**



systemone

emis

vision



**HSC056** seca 376 Baby scale with Extra large weighing tray

**HSC056.2** seca 233 Measuring Rod for seca 376

**HSC106** seca CT-E651 Wireless Printer (with 452 connectivity module)

## seca 955 Class III Approved Chair Scale

Price includes Initial Calibration & Verification with Certificate

- Precise, functional, digital chair scale
- Functions: TARE and HOLD
- BMI Function
- Fold away swivel armrests and adjustable footrests
- Easy to manoeuvre
- Large LCD Display at rear
- Mains/rechargeable battery
- Graduation: 50g < 150kg > 100g
- **Capacity: 250kg**
- Dimensions (WxHxD): 55x920x870mm
- Weight: 23kg
- CE Marked Approval class III



**HSC024.3** seca 955 Class III Approved Chair Scale

## seca 956 Class III Approved Chair Scale

Price includes Initial Calibration & Verification with Certificate

- The simple solution for disabled people
- Functions: TARE, HOLD, automatic switch-off
- The seca 956 is running on batteries instead of mains power
- Fold-up armrests and swivelling footrests for efficiency
- Easy to manoeuvre
- Large LCD Display at rear
- Intuitive operating elements simplify use
- Graduation: 100 g
- **Capacity: 200 kg**
- Dimensions (WxHxD): 563 x 906 x 946 mm
- Weight: 22.4 kg
- CE Marked Approval class III



**HNH140** seca 956 Digital Chair Scale

## seca 959 High Capacity Chair Scale

Price includes Initial Calibration & Verification with Certificate

- Large clear LCD display & touch button HOLD and TARE features, also includes a BMI Function
- Resistant to NHS cleaning agents, including Clinell
- Mains/rechargeable battery
- 50g graduations allows paediatric use as well as bariatric use
- Ideal for Renal Units – wirelessly sending the weighed result directly to the Haemodialysis machine
- Graduation: 50g < 150kg > 100g
- **Capacity: 300kg**
- Dimensions: 55 x 920 x 870mm
- Weight: 23kg

Fully integrates with EMIS, TPP SystemOne and Vision EMR systems, saving time and increasing patient safety. Contact us for more details.



**HSC024** seca 959 Class III Approved Chair Scale - Wireless  
**HSC106** seca CT-E651 Wireless Printer (with 452 connectivity module)  
**HSC024.2** seca 959r Class III Approved Chair Scale with RS232 Interface

## seca 665 Wheelchair Scale Class III

Price includes Initial Calibration & Verification with Certificate

Safety, functionality, aesthetic design the seca 665 sets standards in medical weighing. Specially designed for weighing patients in wheelchairs.

- Extremely flat platform and self adjusting ramp
- Can be folded and transported on castors
- Deduction of wheelchair weight by operator
- HOLD and TARE functions
- **Capacity: 300kg** with graduations 100g < 200kg > 200g
- Dimensions: 1102 x 912 x 1150mm
- Mains/rechargeable battery operation
- Weight: 33.4kg

Fully integrates with EMIS, TPP SystemOne and Vision EMR systems, saving time and increasing patient safety. Contact us for more details.



**HNH002** seca 665 Wheelchair Scale Class III

## seca 685 Wireless High Capacity Multifunction Scale

**Price includes Initial Calibration & Verification with Certificate**

- Ideal for Renal Units – wireless transfer of the weighed result directly to the Haemodialysis machine
- Patients can stand aided by a stable handrail, sit on the integrated folding seat, or remain in a wheelchair
- Resistant to NHS cleaning agents, including Clinell
- When standing, a stable handrail provides a safe point
- Easy to read swivel mounted display at a convenient level
- Integrated transport castors
- Functions: pre-TARE, TARE, HOLD, BMI, weighing range switch over and damping
- **High capacity: 300 kg**
- Graduation: 100 g < 200 kg > 200 g
- Dimensions: 910 x 1100 x 965 mm

**Fully integrates with EMIS, TPP SystemOne and Vision EMR systems, saving time and increasing patient safety. Contact us for more details.**



- HNH307** seca 685 Wireless High Capacity Multifunction Scale
- HNH308** seca 685r High Capacity Multifunction Scale + RS232 Interface
- HSC106** seca CT-E651 Wireless Printer (with 452 connectivity module)

## seca 645 Wireless Hand Rail Scale

**Price includes Initial Calibration & Verification with Certificate**

The diagnosis and therapy of disabled or heavy patients calls for products which meet the specific requirements. The 645 is the perfect choice for these situations.

**Fully integrates with EMIS, TPP SystemOne and Vision EMR systems, saving time and increasing patient safety.**

- Handrail scale with large platform and high capacity
- Extremely low level platform with slip-resistant surface
- TARE, HOLD and BMI features
- Graduations: 100g < 200kg > 200g
- Hand rail integral to scale - no need to let go during weighing
- Weight: 25.4kg
- Dimensions: 640 x 1150 x 600mm
- **Capacity: 300kg**
- Optional height measure: seca 223
- CE marked approval class III



- HNH003** seca 645 High Capacity Hand Rail Scale
- HSC885** seca 223 Height Measure

## seca 677 Electronic Platform Scale

**Price includes Initial Calibration & Verification with Certificate**

Patients can be weighed sitting in a wheelchair or on a chair, whilst the handrail provides valuable support.

- Smooth running transport castors and simple hip level display
- Resistant to NHS cleaning agents including Clinell
- Functions: Pre-TARE, TARE, HOLD, BMI
- **Capacity: 300 kg**
- Graduation: 100 g < 200 kg > 200 g
- Dimensions: 951 x 1107 x 965 mm / Weight: 34.5 kg

**Fully integrates with EMIS, TPP SystemOne and Vision EMR systems. Contact us for more details.**



- HNH063** seca 677 Electronic Platform Scale
- HNH064** seca 677r Electronic Platform Scale with RS232 Interface

## seca 941 Hoist Weigher Class III

When attached to suitable a hoist, the seca 941 Digital Hoist Weigher provides a reliable, accurate and quick weight reading for any user in the attached harness.

This hoist weigher features both a BMI calculation and a Hold function. It also includes a spring safety mechanism that ensures that the user's harness remains securely in place whilst the user is being weighed.

- Attaches onto hoists fitted with coat hanger style spread bars
- Simple and easy to use button interface
- Capacity: 200kg
- Graduation 100g
- CE marked approval Class III



- HSC004** seca 941 Hoist Weigher Class III

## seca 416 Infantometer

- Newly designed baby measuring device
- Curved tray safely holds baby in position
- Lockable foot piece with smooth sliding action
- Simple and easy to use
- Comfortable base for patient
- For babies and infants up to two years
- Measuring range: 33 to 100 cm / 13 to 39"
- Graduation: 1 mm / 1/16"
- Dimensions: 1105 x 165 x 402 mm
- Weight: 3 kg
- CE marked

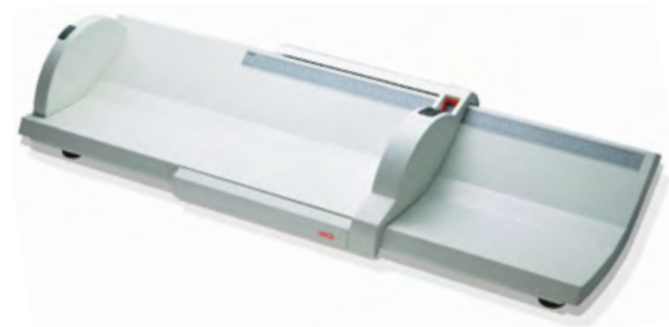

HSC060 seca 416 Infantometer

## seca 417 Baby Measure

The seca 417's fold-up mechanism and low weight make it compact and lightweight for easy transport. It is simple to use and, thanks to its smooth surface, easy to clean.

Durability and a long service life are guaranteed by high-quality materials. Whilst folded the device becomes very flexible, as a compact, portable device.

- Measurement range: 10–100 cm / 4–40"
- Graduation: 2 mm / 1/8"
- Dimensions, measurement board: approx. 1110 x 115 x 300mm
- Dimensions, folded for transport: approx. 577 x 115 x 300mm
- Device weight: approx. 1.4 kg
- 417 folds to become compact & portable

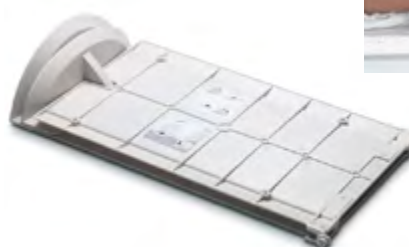

HSC093 seca 417 Baby Measure

HSC092 seca 412 Carry Case

## seca 210 Baby Measure Mat

- Dual range 10 cm/ 4" to 99 cm/39"
- Easy to clean material
- White with black figures
- CE marked



HSC026 seca 210 Baby Measure Mat

## seca 206 Height Measure

- Rolled metal tape measure encased in a sturdy plastic housing
- Improved wall attachment
- Measuring Range: 0-220cm
- Graduations: 1mm
- Dimensions: 120 x 125 x 170mm
- CE marked



HSC035 seca 206 Height Measure



## seca 212 Measuring Tape

- Used to determine head circumference and symmetry of face
- Stretch resistant teflonised plastic
- Resistant to NHS cleaning agents, including Clinell
- Range: 5 to 59cm
- Graduations: 1mm
- Supplied in dispenser of 15 tapes
- CE marked

HSC052 seca 212 Measuring Tape (Box of 15)

seca®



seca®



HSC053 seca 201 Measuring Tape

## seca 201 Measuring Tape

Circumferential measuring tape, quick to hand and extremely practical to operate and store thanks to the roll-up mechanism.

For the measurement, the end of the measuring tape is guided around the body and hooked onto the housing. This allows the measurement result to be read accurately and conveniently. The measuring tape is automatically rolled up at the touch of a button.

- Resistant to NHS cleaning agents, including Clinell
- Measuring range 205 cm
- Graduation 1 mm
- Weight 0.55 g
- Diameter 70 mm

## seca 203 Measuring Tape

seca 203 for determination of body circumference has a high-quality scale of metal used to obtain the Waist-To-Hip-Ratio (WHR). The WHR is an indirect method of determining the amount of abdominal fat tissue.

- Retractable measuring tape for precise body measurements
- Resistant to NHS cleaning agents, including Clinell
- Measurement range: 205 cm
- Weight of device: about 75 g
- Division: 1mm
- Diameter: 70 mm

HSC057 seca 203 Measuring Tape

seca®



seca®

## seca 218 Disposable Measuring Tape



- Disposable measuring tape of high-quality paper to prevent cross infection
- Resistant to NHS cleaning agents, including Clinell
- Uncomplicated removal of measuring tape for immediate use
- At hand at all times from exclusive wall dispenser
- Extra space to write down name, height, weight and date
- Measurement range: 0 - 100 cm
- Graduation: 1 mm
- Weight of device: 4 g
- Dimensions of wall dispenser (WxHxD): 50 x 73 x 36 mm

HSC064.1 seca 218 Disposable Measuring Tape - 500 tapes

## seca 274 Wireless Stadiometer

With the seca 360° wireless technology, the seca 274 can transmit measurements to the optional seca 360° wireless printer.

Equip your PC to receive and analyze data and make all data available to an existing EMR system.

**This capability makes the seca 274 compatible with EMIS, TPP SystemOne and Vision EMR systems. Contact us for details.**

### Free Standing Stadiometer

- Measurement range: 30–220 cm
- Graduation: 1 mm
- Scale Dimensions: 430 x 2400 x 470 mm
- Platform dimensions: 440 x 60 x 365 mm
- Weight of scales: 16 kg
- Power supply: Batteries
- Data transmission: seca 360° wireless
- Functions: HOLD, user-defined zero setting, automatic switch-off

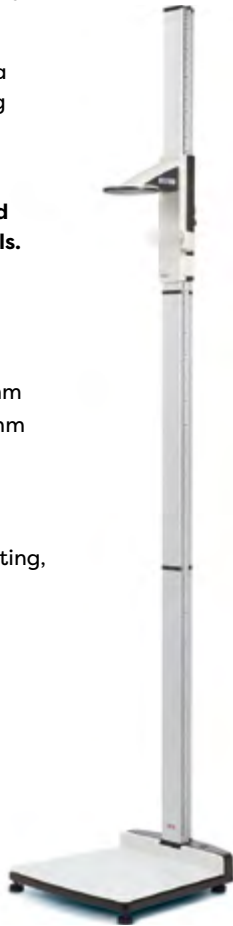

HSC108 seca 274 Wireless Freestanding Stadiometer

## seca 264 Wireless Wall Stadiometer

With the seca 360° wireless technology the seca 264 can transmit measurements to the optional seca 360° wireless printer.

Equip your PC to receive and analyze data and make all data available to an existing EMR system.

**This capability makes the seca 264 compatible with EMIS, TPP SystemOne and Vision EMR systems. Contact us for details.**

### Wall Mounted Stadiometer

- Measurement range: 30–220 cm
- Graduation: 1 mm
- Scale Dimensions: 430 x 2.350 x 480 mm
- Platform dimensions: 430 x 3 x 370 mm
- Weight of scales: 6 kg
- Power supply: batteries
- Data transmission: seca 360° wireless
- Functions: HOLD, user-defined zero setting, automatic switch-off

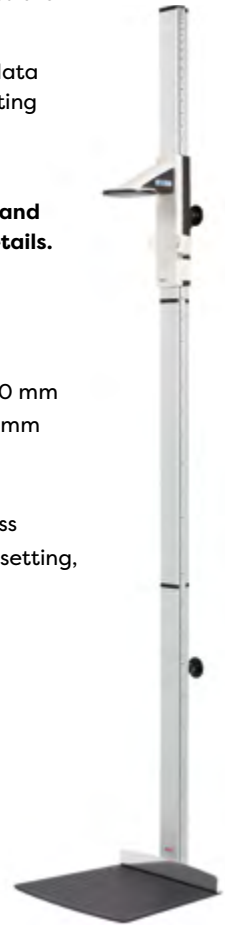

HSC109 seca 264 Wireless Wall Mounted Stadiometer

## seca 216 Wall Mounted Mechanical Height Measure

### Wall Mounted Height Measure

- Measuring range 150 cm/60"
- Resistant to NHS cleaning agents, including Clinell
- Selectable from 10–220 cm / 4–87"
- Dimensions: 120 x 1500 x 217 mm
- Weight: 2 kg
- CE marked



HSC056.1 seca 216 Wall Mounted Mechanical Height Measure

## seca 217 Height Measure

### Solid, robust freestanding height measuring device

- Resistant to NHS cleaning agents, including Clinell
- Suited for use in doctors practices and hospitals
- Measuring range: 20 - 205 cm (8 - 81)
- Graduation: 1 mm / 1/8"
- Dimensions: 328 x 2.145 x 574 mm
- Weight: 3.6 kg



HSC095 seca 217 Height Measure



## seca 222 Height Measure

Telescopic, wall mounting extra height measuring device

- Enlarged head piece folds away for safety
- Eye level read out and heel positioner
- Resistant to NHS cleaning agents, including Clinell
- Dual graduated anodised aluminium
- Measuring range: 6 - 230cm / 2 - 90"
- Graduation: 1mm / 1/8"
- CE marked

seca



HSC028 seca 222 Height Measure

## seca 220 Scale Mounted Height Measure

Scale mounting telescopic height measure

- Eye level reading of patients height
- Resistant to NHS cleaning agents, including Clinell
- Dual graduated anodised aluminium
- Acrylic slide folds down for safety
- Attaches to most seca column scales
- For column scales only
- Range: 85-200cm / 33-78"
- Graduations 1 mm / 1/8"

seca



HSC027 seca 220 Scale Mounted Height Measure

## seca 213 Height Measure

- Light weight & portable
- Ideal for use in a variety of environments
- Approved by The Child Growth Foundation
- Simple and easy to set up, no wall fastening necessary
- Large floor plate ensures stability
- Result clearly visible while measuring
- Convenient and easy to transport
- Measuring range: 20-205 cm / 8-81"
- Graduation: 1 mm / 1/8"
- Dimensions, stadiometer: 337 x 2.130 x 590 mm
- Dimensions, for transport: approx. 337 x 177 x 624 mm
- Device weight: approx. 3 kg
- **Supplied with seca 412 carry case**



HSC110 seca 213 Height Measure

## seca 431 Backpack

- Backpack case for use with the seca 384/385
- Dimensions: 570 x 330 x 150mm
- Weight: 874g

seca



HSC067.1 seca 431 Backpack

## seca 413 Portable Carry Case

- Carry case for use with baby scales seca 385, 384 and 354.
- Dimensions: 570 x 330 x 150mm
- Weight: 900g

seca



HSC067 seca 413 Portable Toddler Carry Case

## seca 428 Carry Case

- Carry case for seca 336
- Dimensions: 660 x 330 x 110mm
- Weight: 2 kg

seca



HSC041 seca 428 Carry Case

## seca 415 Carry Case

- Carry case for seca 877, seca 878 and 875
- Dimensions: 350 x 350 x 60 mm
- Weight 0.9 kg

seca



HSC073 seca 415 Carry Case

## Keito M8 Health Monitor

Measures weight, height, calculates BMI, measures blood pressure and pulse rate in the full operation - or weight, height, BMI in partial mode. The results are printed to a tickets.

Typically used in a waiting room or reception, ideal if used for updating patient records, or allowing patients to monitor their weight BMI and BP on their own.

- Complies with EC Directive 90/384/EEC Class III for non
- Automatic weighing machines
- Max: 220kg / Min: 4kg e=0.2kg
- Measures height up to 200cm (6'7")
- Programmable ticket header and information
- Operates from a standard 13amp electrical socket
- BP: Complies with EC Directive 93/42/EEC Class IIa
- Dimensions: 208 x 58 x 36cm
- Weighs up to 220kg in 0.2kg increments



**HSP1150** Keito M8 Health Monitor

**HSP1151** Keito M8 Health Monitor - Token Operated

**HSP1151.1** Keito PatientPod EMR Patient Record Integration

**HSP1152** Thermal Paper for Keito Health Monitors - 10 Pack

## seca 777 Digital Column Scale Non Medical

Features a tilt-proof full metal platform and robust single peace column, that won't give way when pushing the keypad.

All patients (especially ones affected by obesity) will feel secure on the platform even when stepping on the edge of the base.

With an upgradable network module (seca 452) the seca 787 transmits height/weight measurements directly into your EMR.

- **Not for medical use**
- Robust scale for years of use with high patient volume.
- Built-in measuring rod with 4 - 90" measuring range.
- Digital measuring rod with an extra long measuring range.
- USB interface for EMR integration solutions or PC connectivity.
- Large rubber coated castors for excellent movability.
- Robust tilt-proof full metal platform, no plastic.



**HSC900** seca 777 Column scale with eye-level display

**HSC901** seca 787 EMR validated column scale with eye-level display

## seca 813 Flat Scale - Non Medical

A high capacity, extra wide platform. The tough rubber mat ensures a secure stance and flat construction allows for easy accessibility. The rubber coating takes the heaviest challenges lightly and the flat construction makes stepping on very easy.

- **Not for medical use**
- Capacity: 440 lbs / 200 kg
- Dimensions (WxHxD): 433 x 47 x 373 mm
- Weight: 2.9 kg
- Functions: auto-HOLD, step-off, lbs/kg switch-over, tip-on automatic switch-on, automatic switch-off
- 4 extension feet for carpets
- **Also available with Bluetooth® to transmit weight wirelessly**



**HSC887** seca 813 Non-medical Bluetooth Digital Flat Scale

**HSC887.1** seca 813 Non-medical Digital Flat Scale

## seca 760 Classic Scale - Non Medical

A decades-old classic scale from seca has properties that make it modern today. The scale is always ready for use because it needs neither electrical power or batteries.

The robust mechanical scale weighs quickly, comfortably and precisely. Lovers of classic design will find what they seek in this scale, whose distinctive look leaves a lasting impression.

- **Not for medical use**
- Displays both Kgs & Stone
- Graduation: 500g / 1lb
- Capacity: 150kg / 23sts
- Dimensions: 300 x 105 x 460mm
- Weight: 4 Kg

**seca**



**HSC018** seca 760 Non-medical Mechanical Scale - Black & White

**HSC018.1** seca 760 Non-medical Mechanical Scale - Burgundy Red

**HSC018.2** seca 760 Non-medical Mechanical Scale - Ecru White

**HSC018.3** seca 760 Non-medical Mechanical Scale - Midnight Blue

**HSC018.4** seca 760 Non-medical Mechanical Scale - Black

## Welch Allyn® ABPM 7100

An easy-to-use 24-hour ambulatory blood pressure monitor which offers maximum patient comfort and compliance.

- Highest clinical validation – BHS A/A
- Intelligent inflation provides excellent patient comfort and improves compliance
- Fully flexible program options for various measurement periods and inflation
- Includes Welch Allyn CardioPerfect® Workstation software – the professionals' choice
- Easily create, print, and customise detailed reports that will meet all your needs
- Data can be transferred to all major patient record systems inc. EMIS, Systemone and Vision
- Lightweight, compact and quiet for further patient comfort and compliance
- 100% latex-free and PVC cuffs which will reduce the risk of allergic reactions
- On-site staff training included
- Supplied as standard with 2 cuffs: adult and large adult  
**Special Offer – 3 extra cuffs free of charge (child, small adult, extra large)**

**Baxter**

systemone



<b>HSP510</b>	Welch Allyn® ABPM 7100 Recorder
<b>HSP511</b>	7100 Recorder + CardioPerfect WorkStation Software
<b>HSP510.7</b>	Welch Allyn® ABPM Cuff Extra Large: 38 - 55 cm
<b>HSP510.8</b>	Welch Allyn® 3 Cuff Set – Child, Small Adult and Extra Large
<b>HSP510.9</b>	Welch Allyn® 5 Cuff Set – All 5 sizes

## Microlife WatchBP O3 ABPM 2nd Gen.

Very user-friendly and designed for environments with high hygienic requirements. Additionally, this ABPM can be upgraded to include Central Blood Pressure measurement.

**Customise** with AF Detection, Central BP & Pulse Wave Analysis

- PC connectivity with Bluetooth® and USB, Software included
- 330 data memory for pill intake, event and blood pressure
- Sophisticated design to fulfil hygiene standards
- Highly affordable and fully-programmable
- Standard delivered with M (22-32) and L (32-42) cuffs
- Validated for ESRD End stage Renal Disease
- Clinically validated for children aged 3+, women in pregnancy and pre-eclampsia, diabetes, renal disease and obesity
- Silent mode option for quiet measurements.
- PC connectivity with user friendly PC software. Software included for free allowing easy data analysis.



EMIS Compatible



<b>HSP1299.1</b>	WatchBP O3 24hr 2G with AF Detection
<b>HSP1299.2</b>	WatchBP O3 24hr 2G with AF Detection, Central BP and PWA

**WatchBP03 Compatible Cuffs:**

<b>HSP760.1</b>	Small Cuff for Microlife WatchBP03 ABPM
<b>HSP760.2</b>	Medium Cuff for Microlife WatchBP03 ABPM

## Microlife WatchBP O3 ABPM

Highly affordable 24hr blood pressure monitor with implemented self-measurement schedule. Advanced, user-friendly and highly affordable.

- **24-Hour ABPM Mode** Fully programmable 24hr BP measure
- **Lightweight and Compact** For improved patient comfort
- **PC Connectivity** Transmit BP data to any PC via USB
- **Diagnostic mode** 7-day implemented self-measurement schedule according NICE/ESH/AHA guidelines.
- Pill-button to verify effect of medication
- The software of the WatchBP O3 Ambulatory blood pressure monitor is user-friendly and allows easy data transfer and analysis. WatchBP software is free of charge and can be downloaded from our website to your PC.
- Silent mode option for quiet measurements.
- Standard delivered with M (22-32) and L (32-42) cuffs
- Validated for ESRD End stage Renal Disease
- Validated for use in Pregnancy - Preeclampsia



EMIS Compatible



<b>HSP760</b>	Microlife Watch BP03 ABPM
---------------	---------------------------

<b>HSP760.3</b>	Large Cuff for Microlife WatchBP03 ABPM
<b>HSP760.4</b>	Ex-Large Cuff for Microlife WatchBP03 ABPM

## A&D Medical TM-2441 ABPM with AFib Screening & PatientView360™

The TM-2441 is also clinically validated and designed to meet the new ESH 2018 guidelines. Capable of providing additional supporting data for the clinician - including air temperature, atmospheric pressure and activity tracking using A&D's unique PatientView360™ technology.

With a focus on stroke prevention, the TM-2441 also benefits from A&D's unique AFib+™ and SmartCheck™ technologies enabling screening for Atrial Fibrillation in a single reading.

- **AFib+™:** Screening technology for Atrial Fibrillation and IHB
- **SmartCheck™:** Screen for Atrial Fibrillation in a single reading
- **PatientView360™:** The ability to provide clinicians with improved levels of information about the patient and the environment. This includes the recording of air temperature, patient activity and atmospheric air pressure data.
- Easy to use mode slide switch
- USB & BLE2 Connectivity
- New pulse correction algorithm for faster, quieter measurement
- Battery Power (2 alkaline or Ni-Cd "AA")
- Output to data to analysis software (included with device)
- Ingress protection IP22 & Protocol ISO810601
- Supplied complete with: Adult cuff (22cm-32cm), Large adult cuff (28cm-38cm), carry case and belt
- **Dimensions:** 660 x 245 x 950mm / **Weight:** 120g (no battery)

### Self Measurement Mode Display

**LED display:** This large display shows data from measurements in self-measurement mode. You can easily check the time until the next ABPM measurement in addition to values in self-measurement mode. There are also icons for battery level, Bluetooth status, AFib/IHB detection, clock, mode and memory status.



HSP1263 A&D Medical TM-2441 ABPM with AFib Screening

**A&D**  
A&D Medical

**AFib+**  
SCREENING

**JAPAN**  
Quality & Design

**2 Year**  
Warranty

## A&D Medical TM-2440 ABPM

Compact & lightweight Ambulatory Blood Pressure Monitor, which incorporates our latest technology gained from over 40 years experience in developing and manufacturing precision measurement equipment.

Allows healthcare professionals to automatically monitor a patient's blood pressure throughout the day. ABPM can help differentiate hypertension from white coat hypertension and the data generated can be used to adjust patient medication levels.

Validated in accordance with the new ISO810601-2 protocol, and the blood pressure accuracy was proven to be +/-3mmHg.

- Light weight & compact size
- OLED display (ABPM mode)
- New pulse correction algorithm for faster measurement & noise rejection
- Battery powered (2 alkaline or Ni-Cd "AA")
- Output of data to analysis software (included with device)
- USB connectivity
- Ingress protection IP22 & Protocol ISO810601
- **Supplied complete with:**  
Adult cuff (22cm-32cm), carrying case and belt
- **Dimensions:** 660 x 245 x 950mm
- **Weight:** 120g (no battery)



HSP1265 A&D Medical TM-2440 ABPM

**A&D**  
A&D Medical

**JAPAN**  
Quality & Design

**2 Year**  
Warranty



**Baxter**

## Welch Allyn® ProBP 2000 Digital BP

Capture fast, comfortable, automated blood pressure readings with one button touch. SureBP technology, is a blood pressure averaging algorithm that allows the device to capture blood pressure readings on cuff inflation in a comfortable way for patients.

- Blood pressure readings are captured on inflation in about 20 seconds
- Meets AAMI standards for blood pressure accuracy
- One-button touch triggers the device to start capturing on cuff inflation
- Supplied with one Size 11 FlexiPort Adult Cuff
- Compatible with FlexiPort cuffs sizes 9–13

**HSP1287** ProBP 2000 Digital BP Device with FlexiPort Adult Size 11 (25–34cm) Reuseable BP cuff & 4x AA Batteries

**HSP1288** ProBP 2000 Digital BP Device with FlexiPort Adult Size 11 (25–34cm) Reuseable BP cuff & Power supply

**HSP582** Flexiport Child Cuff Size 9 (15–21 cm)

**HSP583** FlexiPort Cuff Small Adult Size 10 (20–26cm)

**HSP584** FlexiPort Cuff Adult Size 11 (25–34cm)

**HSP585** FlexiPort Cuff Adult Long Size 11L (25–34cm)

**HSP586** FlexiPort Cuff Large Adult Size 12 (32–43cm)

**HSP587** FlexiPort Cuff Large Adult Long Size 12L (32–43cm)

**HSP588** FlexiPort Cuff Thigh Size 13 (40–55cm)

## Welch Allyn® Connex ProBP 3400 BP

Capture fast, accurate readings in the palm of your hand with the same enhanced SureBPTM technology found in Welch Allyn vital signs devices, a smart choice for clinicians in any setting.

Ships standard with one Adult and one Large Adult Cuff.

- **Select your preferred option of either the Basic Model or SureBP**
- USB-wired technology enables integration to select EHR/EMR systems
- Compatible with Welch Allyn FlexiPort® cuff sizes from small child to thigh
- Lithium ion battery technology delivers up to 100 readings on a single charge
- Configurable to match your workflow and specific patient needs
- Meets AAMI Standards, awarded BHS A/A rating.
- Obtains accurate readings, even in the presence of some motion or weak pulse

**HSP1012** Connex ProBP 3400 Handheld BP Monitor with SureBP

**HSP1015** Connex ProBP 3400 Handheld BP Monitor

**HSP582** Flexiport Child Cuff Size 9 (15–21 cm)

**HSP583** FlexiPort Cuff Small Adult Size 10 (20–26cm)

**HSP584** FlexiPort Cuff Adult Size 11 (25–34cm)

**HSP585** FlexiPort Cuff Adult Long Size 11L (25–34cm)

**HSP586** FlexiPort Cuff Large Adult Size 12 (32–43cm)

**HSP587** FlexiPort Cuff Large Adult Long Size 12L (32–43cm)

**HSP588** FlexiPort Cuff Thigh Size 13 (40–55cm)



## A&D Medical UM-102 Series

- Auscultatory blood pressure measurement
- Digital readout for pulse rate
- Cuff holder and grip for carrying
- Durable and chemical resistant body
- Full ABS housing light weight body
- Professional cuff and 5 cuff sizes are available for use
- Adjustable display column for easier analysis of result
- Easy battery replacement
- Anti-glare display minimizes reflected light
- Supplied with adult cuff (22-32cm)
- **Available as a portable model with a mobile stand or as an upright stand model perfect for desks**



**A&D**  
A&D Medical

JAPAN  
Quality & Design

3 Year  
Warranty

**HSP1221** A&D Medical UM-102A Desktop Model

**HSP1222** A&D Medical UM-102B Portable Model

## A&D Medical TM-2657P Waiting Room BP Monitor with Stand

Widely used in pharmacies, hospitals and GP surgeries – It is estimated that over 1 in every 7 GP surgeries use it in the UK!

Enables patients to 'self-screen' and take their own blood pressure readings (and weight using a connected medical scale). This saves valuable clinical staff time, and therefore cost. It also allows clinical staff to see more patients, and to focus on the patients that most need help.

- **Designed for 'high foot fall' areas to save time and money**
- **BHS A/A Clinically Validated**
- Return on Investment (ROI) normally within 6 months
- Can be integrated to Electronic Patient Record solution (EPR)
- User-friendly small footprint & barrier-free design
- Simple to use, one-touch measurement
- "Torque Controlled Belt drive Method" (TCBM)
- Antibacterial arm cuff cover, reduces risk of cross infection
- Network connectivity options using Bluetooth or RS-232
- Reliable high speed printer with easy paper replacement
- Irregular Heart Beat (IHB) indicator
- **HSP1234:** The additional 2 channel option can be used to connect A&D weighing scales with RS232C connectivity. This option also has the ability to connect with Electronic Patient Record systems\*



**A&D**  
A&D Medical

JAPAN  
Quality & Design

3 Year  
Warranty

**BP stand included.  
Stool not included.**

\* This will require additional software integration not handled by HCE

**HSP1226** Fully Auto BP Monitor with Stand

**HSP1234** Fully Auto BP Monitor with Stand & External in/output RS 2ch

**HSP1227** Replacement Stand for TM-2657P



**A&D**  
A&D Medical

JAPAN  
Quality & Design

3 Year  
Warranty

## A&D Medical UM-211 Dual Measurement BP Monitor

- Dual measurement modes (Auscultatory and Oscillometric)
- Durable and chemical resistant body – for easy cleaning to Hospital infection control standards
- Professional cuff with 5 cuff sizes covering 12cm to 50cm
- Shock-proof 'bumper' to protect it from accidental damage
- Large angled LCD display with backlight
- Fully rechargeable long-life battery (providing 300 measurements when fully charged)
- Adjustable inflation pressure (AUTO/220/250/280)
- Selectable deflation speed (2.5mmHg/sec or 5.0mmHg/sec)
- Room temp. display & Irregular Heart Beat (IHB) indicator
- ESH Clinical Validation
- Supplied with adult cuff (22-32cm)

**HSP1224** A&D Medical UM-211



## A&D Medical UA-767S-W BP with AFib Screening & Wide Range Slim Cuff

The UA-767S-W is the latest in the range of UA-767 devices from A&D – our flagship model since 1985. It benefits from our 2nd generation IHB technology, shown by icons and divided into different grades.

- 3rd generation of the flagship UA-767 range
- Slimfit™ Wide Range Cuff – latex & metal free **22-42cm**
- 2nd generation IHB (Irregular Heart Beat) Indicator to show frequency IHB%
- Cuff Fit Error Indicator and Movement Error Indicator
- WHO Blood Pressure Classification Indicator
- 60-memory + Average Reading
- **ESH Clinical Validation**



**HSP516.1** A&D Medical UA-767S-W with Wide Range Slim Fitting Cuff

## A&D Medical UA-767S BP with AFib Screening & Slim Cuff

The UA-767S is the successor of the UA-767 series for personal use (single user), focused on “Simple operation”. This monitor is easy to use and features the % IHB function. The memory has been upgraded to 60 readings.

- 3rd generation of the flagship UA-767 range
- Slimfit™ Adult Cuff – latex and metal free, covering **22-32cm**
- 2nd generation IHB (Irregular Heart Beat) Indicator to show frequency IHB%
- Cuff Fit Error Indicator and Movement Error Indicator
- WHO Blood Pressure Classification Indicator
- 60-memory + Average Reading
- **ESH Clinical Validation**



**HSP516** A&D Medical UA-767S with Slim Fitting Cuff

## A&D Medical UA-1020W BP monitor with wide range cuff and AFib screening

UA-1020W includes a wide range cuff (22-42cm) and includes irregular heartbeat indication & Atrial Fib. screening features

- Large, wide range adult cuff **22-42cm** size cuff
- Advanced Oscillometric method for professional accuracy and proven reliability
- 90 reading internal memory with total average, AM and PM average recall
- AA Grade validation to the British Hypertension Society accuracy protocol
- Cuff fit error and movement function
- Designed and engineered in Japan for professional clinical use
- Large LCD display and easy one button operation
- Built in clock with date and time stamp
- TriCheck measurement & WHO BP classification indicator



**HSP1002.1** A&D Medical UA-1020W with Wide Range Cuff

**HSP141.3** Small Cuff for UA Series (16-24cm)

## A&D Medical UA-1020 BP Monitor with AFib screening & Tri Check™

Offers TriCheck™ measurement which allows users to take three consecutive readings and receive an average, complying with the American Heart Association's latest recommendation.

- Advanced inflation technology for quicker measurement
- SmoothFit cuff™ (patent pending), covering **17cm – 32cm**
- **AFib+™**: Screening technology for Atrial Fibrillation and IHB
- **TriCheck™ mode for automatic 3 reading average**
- 90 reading memory with AM/PM, average for NICE compliance
- All readings timed and dated
- Irregular Heartbeat Indication feature and WHO Result guide
- **BHS A/A Clinically Validated**



**HSP1002** A&D Medical UA-1020

**HSP141.3** Small Cuff for UA Series (16-24cm)

**HSP141.4** Mains Adaptor

**HSP141.1** Adult Cuff for UA Series (22-32cm)

**HSP141.2** Large Cuff for UA Series (31-45cm)

### Omron NEW M3 BP Monitor

The New M3 comes complete with an Easy Cuff and features an LCD digital display, internal memory and simple to use controls. With battery life capable of around 1000 measurements and detection for irregular heartbeat.

- Clinically validated in general populations and for people who are pregnant or who have diabetes
- Indicates if irregular heartbeat is detected
- 2 Users, 60 Memories & Guest Mode
- **Includes:** Monitor, Easy Cuff (22-42cm), 4x AA Batteries and a protective storing case.
- **Dimensions:** 105 x 87 x 145mm (WxHxL)
- **Weight:** Approx. 310g



**OMRON**  
 No.1 recommended brand by **CARDIOLOGISTS**  
\*The Heart Blood Pressure Monitor is Doctor (2015) Patient Health Survey with cardiologists (2015)  
 3 Year Warranty

- HSP1296** Omron M3 Upper Arm BP Monitor with Easy Cuff (22-42cm)
- HSP1157.1** Omron Easy Cuff (22-42cm)
- HSP010-S** Small Cuff for Omron B.P. Monitors (17-22cm)

### Omron NEW M6 Comfort BP Monitor

The New M6 comes complete with a Comfort Cuff and is able to detect an irregular pulse which is suggestive of Atrial Fibrillation (Afib), it features an LCD digital display, large internal memory and easy controls. With battery life capable of around 1000 regular measurements and detection of irregular heartbeat.

- Clinically validated in general populations and for people who are pregnant or who have diabetes
- 2 Users, 100 Memories & Guest Mode
- Indicates if irregular heartbeat is detected
- **Afib Indicator function**
- **Includes:** Monitor, Comfort Cuff, 4x AA Batteries and protective storing case.
- **Dimensions:** 191 x 85 x 120mm (WxHxL)
- **Weight:** Approx. 460g



**OMRON**  
 No.1 recommended brand by **CARDIOLOGISTS**  
\*The Heart Blood Pressure Monitor is Doctor (2015) Patient Health Survey with cardiologists (2015)  
 3 Year Warranty

- HSP1297** Omron M6 Upper Arm BP Monitor with Comfort Cuff (22-42cm)
- HSP613** Omron Comfort Cuff (22-42cm)

### OMRON

No.1 recommended brand by **CARDIOLOGISTS**  
\*The Heart Blood Pressure Monitor is Doctor (2015) Patient Health Survey with cardiologists (2015)



### Omron NEW M7 Intelli IT

The New M7 Intelli monitor is able to store over 100 blood pressure measurements and is able transfer these via Bluetooth to the Omron Connect App. Omron connect makes it easy to view, save, and manage your health data.

- Clinically validated in general populations and for people who are pregnant or who have diabetes
- 2 Users, 100 Memories & Guest Mode
- OMRON connect mobile application for iPhone / Android
- Indicates if irregular heartbeat is detected
- **Afib Indicator function**
- **Includes:** Monitor, Omron Connect, 4x AA Batteries and protective storing case.

- HSP1298** Omron NEW M7 Intelli IT
- HSP1160.1** Omron Intelli Wrap Cuff (22-42cm)

### Omron RS7 Intelli IT

An automatic wrist blood pressure monitor, operating on the oscillometric principle. This blood pressure monitor is to be worn on your wrist. When the cuff inflates, the monitor senses the pressure pulsations of the artery underneath the cuff

- Intellisense Technology
- OMRON connect mobile application for iPhone / Android
- Cuff wrapping guide
- Irregular heartbeat detection
- Pre-formed easy to fit cuff
- Stores up to 100 readings per user
- Average of 3 readings

- HSP1271** Omron RS7 Intelli IT



**OMRON**  
 No.1 recommended brand by **CARDIOLOGISTS**  
\*The Heart Blood Pressure Monitor is Doctor (2015) Patient Health Survey with cardiologists (2015)  
 3 Year Warranty



## Omron 907 Professional BP Unit

Versatility and accuracy when you need it most

This fully automatic blood pressure monitor was designed with the professional in mind. Its versatility is proven with the ability to be used fully automatically or manually controlled. Can be used either as an oscillometric or auscultatory device. Loaded with Intellisense features that ensures accuracy and comfort.

- Intellisense technology
- Optional oscillometric and auscultatory measurements are possible
- Programmable average of multiple measurements
- Supplied with rechargeable batteries and adapter
- Hide function for readings
- Clinically Validated



<b>HSP315</b>	Omron 907
<b>HSP316</b>	Omron 907 on Mobile Stand
<b>HSP317</b>	Omron 907 Medium Cuff 22-32cm
<b>HSP317.1</b>	Omron Spare Tubing for cuff with Connectors
<b>HSP318</b>	Omron 907 Small Cuff 15-22cm
<b>HSP319</b>	Omron 907 Large Cuff 32-42cm

## Omron ECG & Smart BP Monitor

Easy home screening to monitor risk of stroke

The clinically validated OMRON Complete is a 2-in-1 smart home blood pressure monitor and ECG that gives you easy, instant and accurate results. Easily take two critical measurement in one go, for hassle-free heart monitoring from the comfort of home.

Quickly screen for a range of heart conditions at once, including: Heart rhythm irregularities, such as AFib, tachycardia, bradycardia as well as hypertension.

- ECG Recording
- Blood Pressure Measurement
- Afib indicator function
- Record measurements
- Intellisense technology
- Cuff Wrap Guide
- Clinically validated
- Omron connect app



<b>HSP009</b>	Omron 7530T-E3 ECG & Smart Blood Pressure
---------------	---

## Omron HBP-1120

Professional Blood Pressure Monitor is meant for measurement of blood pressure on the basis of the oscillometric principle.

- Zero indicator function - Before each measurement, this device indicates that "zero setting" was successful
- Auscultation Mode
- Range of 5 Cuffs available (See below)
- This device and cuff can be cleaned with a soft cloth moistened with alcohol.
- Compact, can be stored in a drawer
- Motion stop function - When body movement is detected, the device stops deflation for 5 seconds.
- Irregular pulse icon - Helps identify changes in heart rate, rhythm, or pulse that may be caused by heart disease or other serious health problems.



<b>HSP1272</b>	Omron HBP-1120
<b>HSP1272.1</b>	Omron XS Cuff Size 12-18cm (1.0m)
<b>HSP1272.2</b>	Omron S Cuff Size 17-22cm (1.0m)

## Omron HBP-1320

Professional Blood Pressure Monitor is meant for measurement of blood pressure on the basis of the oscillometric principle. Includes Auto-Off feature and Rechargeable battery

- Range of 10 cuffs available in 1m or 4.5m (See below)
- Motion stop function (When body movement is detected, the device stops deflation for 5 seconds.)
- Irregular pulse Indicator - Helps identify changes in heart rate, rhythm, or pulse which may be caused by heart disease or other serious health issues.
- 4 Inflation Pressure Options: Auto, 220, 250 or 280 (mmHg)
- Last reading display function



<b>HSP1279</b>	Omron HBP-1320
<b>HSP1272.3</b>	Omron M Cuff Size 22-32cm (1.0m)
<b>HSP1272.4</b>	Omron L Cuff Size 32-42cm (1.0m)



## Omron Nightview Wrist Monitor

### Automatic Wrist Blood Pressure Monitor

NightView is a completely silent way to measure daytime blood pressure and automatically measure nighttime blood pressure, while still sleeping soundly.

The first at-home wrist monitor designed to measure nighttime blood pressure. Even with controlled daytime blood pressure, 1 in 4 people still has a condition called nocturnal hypertension.

- 3x automatic measurement function during the night
- Clinically validated in sitting and supine position with different rotations of the wrist
- Completely silent due to the Piezzo pump
- Measuring during the inflation
- Advanced Positioning Sensor
- 1 user 350 memories
- OMRON connect app

**HSP009.1** Omron 9601T-E3 Nightview Wrist Monitor

## Riester ri-champion smartPRO+ BP Monitor

Clinically validated blood pressure monitor, designed for fast and reliable readings. Advanced performance by indicating irregular heartbeat detection and average measurement function.

Available with your preferred choice of two cuff sizes, and with optional Bluetooth for data transfer. The device has a large backlit LCD screen and power saving features.

- Fast and low noise measurements
- Irregular heartbeat detection
- Average BP measurement function
- 200 measurements with one set of batteries
- Optional Bluetooth connectivity and mains adapter
- Automatic off function - if left idle for 3 minutes
- CE /FDA approved with IP21 Water protection
- **Memory:** Maximum 400 memory records
- **Power Saving:** Automatic power off if system idle for 3 mins
- **Dimensions/Weight:** 141 x 121 x 72mm (LxWxH), 350 g
- **Small Cuff (S):** 15-24 cm (5.9-9.4 inches) air tube 80 cm
- **Wide Cuff (W):** 24-43 cm (9.4-16.9 inches) air tube 80 cm

**HSP1302.4** Wide Cuff (24 - 43 cm)

**HSP1302.5** Small Cuff (15 - 24 cm)



**HSP1302** smartPRO+ with Bluetooth and Wide Cuff

**HSP1302.1** smartPRO+ without Bluetooth and Wide Cuff

**HSP1302.2** smartPRO+ with Bluetooth and Small Cuff

**HSP1302.3** smartPRO+ without Bluetooth and Small Cuff

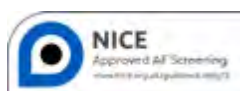

## Microlife WatchBP Office Vascular ABI

### Professional Office BP and Cardiovascular Screening Monitor

Dual-cuff blood pressure monitor with Atrial Fibrillation (AF) detection and Ankle-Brachial Index (ABI) function. Validated professional automatic office blood pressure device which can assess the ankle brachial index (ABI) fast and accurate.

- Screens for Atrial Fibrillation (AF) with high accuracy (sensitivity 98% - specificity 92%) as demonstrated in multiple comparative studies with 12-lead ECG.1-10
- Fast, easy, and accurate Ankle Brachial Index (ABI)
- User-friendly with high reproducibility brachial-ankle PWV measurement method to evaluate arterial stiffness.
- Plethysmography (PVP) waveforms to help in making a reliable diagnosis of cardiovascular risk and hypertension.
- Adjust the settings of time intervals and numbers of consecutive measurements to comply with varying guidelines.

**HSP008** Microlife WatchBP Office Vascular ABI



## Microlife WatchBP Home Series

The Microlife WatchBP Home devices are clinically validated and can be used in both professional and home environments.

These modern, compact and lightweight devices offer a range of BP measuring options for daily or nightly use from home. There are a range of cuff sizes available to meet the needs of each individual user.

### Microlife WatchBP Home

Eliminates most of the physicians concerns about the quality of the home measurements by being the world's first, clinically-validated home BP measurement device with an implemented schedule that strictly follows NICE, ESH and AHA guidelines for self-measurement. In the "Diagnostic" mode, patients perform morning and evening measurements for 7 days, as prescribed.

- Diagnostic mode - 7-day implemented self-measurement schedule according NICE/ESH/AHA guidelines.
- Usual mode - Stores up to 250 regular measurements and display the average with the push of a button.
- Automated data tabulation and intuitive display of averages for morning, evening and multi-day measurement data.
- Transmits BP measurement data to any PC via USB.



**HSP762** Microlife WatchBP Home BP Monitor

This home series can eliminate most of the physicians concerns about the quality of the home measurements by being the world's first range of clinically-validated home BP measurement devices.

Physicians can read the data from the device or PC with the added software, at the next visit.

### Microlife WatchBP Home S

Tested and approved for detecting Atrial Fibrillation WatchBP AFIB detects Atrial Fibrillation with high accuracy (sensitivity 98%, specificity 92%) as demonstrated in multiple comparative studies with ECG.

- Simultaneously screening for AF and high BP at home
- Animated reminder when risk factors been detected
- Screening for AF is recommended by leading medical societies [1, 2]
- Easy-to-Read: Large screen displays
- Medical Consultation Reminder: Lights up if AF and/or high blood pressure is detected
- Compact & Lightweight: Easy to carry and easy to store



**HSP761** Microlife WatchBP Home S BP Monitor

### Microlife WatchBP Home A

The WatchBP Home A is a Home device equipped with an atrial fibrillation detection system.

When you have high blood pressure and/or experience (periods of) atrial fibrillation the WatchBP Home A is the best device to diagnose this.

- Tested and approved for detecting Atrial Fibrillation WatchBP AFIB detects Atrial Fibrillation with high accuracy (sensitivity 98%, specificity 92%) as demonstrated in multiple comparative studies with ECG.
- Embedded NICE/ESH/AHA measurement guidelines lead to accurate home measurement data physicians can trust.
- Automated data tabulation displays averages for morning, evening and overall blood pressure data.

**HSP763** Microlife WatchBP Home A



#### Adapter and Cuffs:

**HSP762.1** Mains Adaptor for WatchBP Home

**HSP762.2** Small Cuff (17-22cm) for WatchBP Home

**HSP762.3** Medium Cuff (22-32cm) for WatchBP Home

**HSP762.4** Large Cuff (32-42cm) for WatchBP Home

**HSP762.5** Extra Large Cuff (32-52cm) for WatchBP Home

## Microlife WatchBP Office Series

A range of sophisticated, office blood pressure measurement devices. Most office series BP monitors feature dual cuff measuring and can identify risks such as strokes or heart disease.

These professional, compact and lightweight devices offer varying screening options. They also include multiple, modern features to aid the user. A full range of cuffs are available.

### Microlife WatchBP Office ABI

A sophisticated, affordable cardiovascular screening device. This device allows fast and easy screening for cardiovascular risk factors such as AFIB, peripheral arterial disease and hypertension.

- Screen Mode: Perform simultaneous double-arm BP measurements which are recommended by several guidelines to be performed at each first visit
- ABI Mode: Following the 'Screen Mode' the ABI Mode can then be used to screen for hypertension, PAD and AF.
- Routine Mode: A regular BP monitor using "routine" mode, here the device automatically performs three subsequent measurements in a row (or less, when preferred) on one arm



**HSP768** Microlife WatchBP Office ABI

### Microlife WatchBP Office AFIB

Dual-cuff blood pressure (BP) measurement and atrial fibrillation (AF) detection with built-in auscultatory measurement function

- Simultaneously screening for AF and IAD
- Ideal tool for population screening and diagnosis for stroke and heart disease
- Tested and approved for detecting Atrial Fibrillation WatchBP AFIB detects Atrial Fibrillation with high accuracy (sensitivity 98%, specificity 92%) as demonstrated in multiple comparative studies with ECG.
- Sensitivity and 89% Specificity while measuring BP
- One touch for detecting BP value and AF condition



**HSP767** Microlife WatchBP Office AFIB

### Microlife WatchBP Office Central

Offering central blood pressure measurement, which may better correlate with cardiovascular risk because the aorta is more close to the heart and brain.

- Non-invasive central blood pressure measurement.
- Fast and accurate Ankle Brachial Index (ABI) assessment.
- Atrial fibrillation (AF) detection.
- Dual-cuff design for simultaneous measurement on both arms to assess the Inter-Arm-Difference (IAD).
- This device also shows the measured Mean Arterial Pressure (MAP) and the Pulse Pressure (PP).

**Supplied with:** 2x M-L Cuff (22-42cm / 8.7-16.5"), 1x M-Cuff (22-32cm) ankle, Instruction Manual, Power Adapter, USB-Cable and Software



**HSP770** Microlife WatchBP Office Central

### Microlife WatchBP Office 2nd Generation

Provides high accuracy in the evaluation of BP for the general population and for so-called "special patients". Measure patients with weak artery signals with "Manual Mode".

**Customise** with AF Detection, Central BP & Pulse Wave Analysis

- PC connectivity with Bluetooth® and USB, Software included
- Display of Mean Arterial Pressure (MAP) & Pulse Pressure (PP)
- Flexible BPM schedule to help physicians worldwide who are adhering to different measurement recommendations.
- Automated office blood pressure measurement (AOBPM)
- Clinically validated for children aged 3+, pregnancy and pre-eclampsia, diabetes, renal disease and obesity



**HSP1300** WatchBP Office 2G (Standard)

**HSP1300.1** WatchBP Office 2G with AF detection

**HSP1300.2** WatchBP Office 2G with AF Detection, Central BP and PWA

#### Office Series Cuffs:

**HSP765.1** Small Cuff for WatchBP Office Target

**HSP765.2** Medium Cuff for WatchBP Office Target

**HSP765.3** Large Cuff (32-42cm) for WatchBP Home

**HSP765.4** X-Large Cuff for WatchBP Office Target



Made in the UK



#### Mobile Stand

- A large container for the cuff and tubing on which the greenlight 300 is fitted
- Gauge set at an angle for easy viewing
- A mounting stem with adjustable height, with five castors for mobility and stability

## ACCOSON™ Greenlight 300

The greenlight 300 has been developed to provide a reliable and accurate alternative without mercury. This is achieved using silicon chip technology replacing the traditional mercury column with an electronic pressure detection system.

Validated to the ESH International Protocol by the Mayo Clinic. It is also sold as a test reference manometer for calibrating and checking aneroid devices – chosen by leading pharmaceutical companies for their testing services in the UK.

#### BHS Approved and The Accurate Alternative to Mercury

- **10 Year calibration warranty**
- Automatic calibration check of the display by pressure zero each time it is switched on ensures reliable accuracy
- A large bright scale display – Moving light indicates pressure
- Device display design encourages measurement to 2mmHg as recommended by the British Hypertension Society
- Guaranteed accuracy of +/- 3mmHg
- Clinicians retain the trusted confidence of the Riva-Rocci/Korotkoff manual method of measurement
- The cuff deflation rate display helps users deflate between 2–3 mmHg as recommended by the BHS
- Long battery life (typical 170 hours) with low battery indicator
- Device validated to the new International Protocol by the Mayo Clinic in the USA
- Device suitable for all patient groups, including the pregnant and the elderly
- Latex free inflation system & coiled tubing

**HSP128** White – Desk Model with Adult Ambidex Cuff

**HSP130** Wall conversion kit for greenlight

**HSP131** Mobile stand conversion kit for greenlight

## ACCOSON™ Six<sup>00</sup> Series

The Six<sup>00</sup> range of sphygmomanometers represent our premium quality aneroid sphygmomanometers.

The sensitivity and specificity of these models, help to classify an individual as hypertensive or normotensive.

#### Made in UK and guaranteed accuracy to BS EN ISO 81061-1

- **Supplied with a 3 year calibration warranty**
- Range of 0–300 mmHg, with the scale calibrations starting at zero
- Guaranteed accuracy of +/- 3mmHg
- Clear white face with fine red pointer gives pin point visibility
- Smooth lines for easy cleaning without awkward areas
- Designed to withstand double full scale overpressure
- Five year calibration warranty
- Lightweight ABS cuff holder is easy to clean
- Desk model features a new flexible shock mount which resists damage to the gauge
- Wall model with mounts for fixed or swivel operation
- Hole free wall mounting available using optional velcro plate
- Mobile model with adjustable height and inclined gauge

#### Fitted with Adult ambidex, latex free cuff as standard

**HSP865** ACCOSON™ Six<sup>00</sup> Aneroid – Desk Model

**HSP866** ACCOSON™ Six<sup>00</sup> Aneroid – Wall Model

**HSP867** ACCOSON™ Six<sup>00</sup> Aneroid – Mobile Stand Model



## ACCOSON™ 6 inch Series

The Six Inch range of sphygmomanometers provide clinicians with amazing quality at affordable prices.

A modern solution for all locations with innovative and practical features.

**Made in UK and guaranteed accuracy to BS EN ISO 81061-1**

- Supplied with a 1 year calibration warranty
- Range of 0–300 mmHg, with the scale calibrations starting at zero
- Guaranteed accuracy of +/- 3mmHg
- Fine red pointer ensures consistently precise indication
- Clear white face with sharp black scale
- Large diameter white dial
- Wall model includes swivel mounting bracket
- Desk model features new flexible shock mount which resists damage to the gauge
- The stand model has the gauge inclined for easy viewing and a weighted base with five castors.
- Cuff storage space located behind the dial

**Fitted with Adult ambidex, latex free cuff as standard**

**HSP062** ACCOSON™ 6 inch Aneroid – Wall Model

**HSP063** ACCOSON™ 6 inch Aneroid – Desk Model

**HSP064** ACCOSON™ 6 inch Aneroid – Mobile Stand Model



## ACCOSON™ Duplex Aneroid

Made to be held and inflated with one hand, leaving the other free to hold the stethoscope in place when taking a BP reading. Moreover, it is a more traditional design and is made completely from metal parts. Therefore, it is solid and very durable.

**Made in UK and guaranteed accuracy to BS EN ISO 81061-1**

- One-handed use, with thumb and fingertip control
- Latex free inflation system
- Supplied with adult ambidex in soft case with zip fastener
- Available as blue/red to allow for easy owner identification
- Lightweight diecast case
- Range 0-300mmHg
- Guaranteed accuracy of +/- 3mmHg

ACCOSON



**HSP067** ACCOSON™ Duplex Aneroid – Ambidex

**HSP067.1** ACCOSON™ Duplex Aneroid – Blue

**HSP067.2** ACCOSON™ Duplex Aneroid – Red

## ACCOSON™ Limpet

**Limpet Hand Model with Straight/Coiled tube**

Designed for use in much the same way as the Duplex. However, this version is much lighter and less bulky. It is a good value option, providing a great balance of price with trusted accuracy.

**Made in UK and guaranteed accuracy to BS EN ISO 81061-1**

- One-handed use, suitable for both right and left hands
- Lightweight plastic moulded case
- Supplied with adult velcro cuff and coiled tube or ambidex adult cuff and straight tube in soft case
- Range 0-300mmHg
- Guaranteed accuracy of +/- 3mmHg
- Cuff set includes one of each cuff size
- Latex free throughout

ACCOSON



**HSP098** ACCOSON™ Limpet Coiled Tube

**HSP098.2** ACCOSON™ Limpet with Straight Tube

**HSP098.3** ACCOSON™ Limpet with Straight Tube and Cuff Set



## ACCOSON™ Pocket

Has a belt clip on the back of the gauge to slide onto the blood pressure cuff when taking a BP measurement. This means the device does not need to be held in position or placed on a nearby surface, the gauge is facing the user and allows very convenient viewing of the device during a BP reading.

**Made in UK and guaranteed accuracy to BS EN ISO 81061-1**

- Lightweight diecast metal case
- Clip on back of gauge for fitting to cuff
- Range 0-300mmHg
- Guaranteed accuracy of +/- 3mmHg
- Supplied in soft zipper case with adult ambidex cuff
- Latex free throughout

ACCOSON



Made in the UK



HSP099 ACCOSON™ Pocket

## ACCOSON™ Combine – Self Test Model

Accurate Aneroid Sphyg combined with integrated stethoscope. Reliable, single handed use aneroid blood pressure sphyg.

Lightweight and portable. With built in stethoscope for combined use.

**Made in UK and guaranteed accuracy to BS EN ISO 81061-1**

- One-handed use, suitable for both right and left hands
- Supplied in soft pouch case with zip fastener
- Range 0-300mmHg
- Guaranteed accuracy of +/- 3mmHg
- Supplied with latex free adult velcro cuff and bulb
- Includes integral stethoscope

ACCOSON



Made in the UK



HSP145 ACCOSON™ Self Test

## Accoson Single Patient Cuffs

Due to current demand, we are pleased to expand our blood pressure cuff offering to include latex free Single Patient Use Cuffs.

Disposable cuffs designed for use with our sphygmomanometer range. **Suitable for use with other manufacturers** manual or electronic syphgmomanometers.

- Completely Latex Free
- Specifically designed as single patient use
- Cuffs are available in either single or double tube
- Suitable for use with all ACCOSON™ sphygmomanometers
- Also capable of use with other manufacturers sphygmomanometers
- Quantity: Pack of 5

HSP060.1 Adult Cuff (26–35cm) - Single Tube (5 Pack)

HSP060.2 Large Adult Cuff (34.3–50.9cm) - Single Tube (5 Pack)

HSP060.3 Thigh Cuff (40.6–66.5cm) - Single Tube (5 Pack)

HSP060.4 Child Cuff (19–27.2cm) - Single Tube (5 Pack)

HSP061.1 Adult Cuff (26–35cm) - Double Tube (5 Pack)

HSP061.2 Large Adult Cuff (34.3–50.9cm) - Double Tube (5 Pack)

HSP061.3 Thigh Cuff (40.6–66.5cm) - Double Tube (5 Pack)

HSP061.4 Child Cuff (19–27.2cm) - Double Tube (5 Pack)

ACCOSON



Made in the UK





## ACCOSON™ Ambidex Innovative Blood Pressure Cuffs

- Ambidextrous cuffs can be used on either the left or right arm
- Inlet tube positioned in the centre of the cuff face frees space for the stethoscope and keeps tubing on the outside of the arm
- 'CUFF RANGE' and 'ARTERY' position indicator can be read when cuff is on either arm
- Tab for aneroid gauge or for use as a tube tidy
- Easily cleaned; antimicrobial treated
- Full range of sizes based on British Heart Foundation recommendations
- Latex-free throughout
- Panel for single patient or cuff identification if required
- Single and double tube option, with a full range of tube connectors

Size	Cuff Range	Single Tube Code	Dual Tube Code
Adult Sized	24-35cm	HSP100	HSP105
Large Adult Sized	34-46cm	HSP101	HSP106
Thigh/Outsize Sized	45-60cm	HSP102	HSP107
Child Sized	18-25cm	HSP103	HSP108
Infant Sized	13-19cm	HSP104	HSP109

## ACCOSON™ Cuffs and Accessories



<b>HSP074</b>	Velcro Cuff Single Tube – Thigh 44-61.5cm
<b>HSP071</b>	Velcro Cuff Single Tube – Outsize Adult 33-47.5cm
<b>HSP070</b>	Velcro Cuff Single Tube – Alternative Adult 27.5-42cm
<b>HSP068</b>	Velcro Cuff Single Tube – Adult 24-33.5cm
<b>HSP072</b>	Velcro Cuff Single Tube – Child 20-26.5cm
<b>HSP074.1</b>	Velcro Cuff Single Tube – Young Child 9-14.5cm
<b>HSP073</b>	Velcro Cuff Single Tube – Infants 12-17cm
<b>HSP074.2</b>	Velcro Cuff Single Tube – Newborn 9-14.5cm

<b>HSP081</b>	Inflation Bulb and Control Valve
<b>HSP082.2</b>	Male/Female Tube Connector (10x Pairs)
<b>HSP080</b>	Velcro Cuff Double Tube – Thigh 44-61.5cm
<b>HSP077</b>	Velcro Cuff Double Tube – Outsize Adult 33-47.5cm
<b>HSP076</b>	Velcro Cuff Double Tube – Alternative Adult 27.5-42cm
<b>HSP075</b>	Velcro Cuff Double Tube – Adult 24-33.5cm
<b>HSP078</b>	Velcro Cuff Double Tube – Child 20-26.5cm
<b>HSP080.1</b>	Velcro Cuff Double Tube – Young Child 17-22cm
<b>HSP079</b>	Velcro Cuff Double Tube – Infants 12-17cm
<b>HSP080.2</b>	Velcro Cuff Double Tube – Newborn 9-14.5cm



**HSP1239**

**HSP1240**

Includes colour-coded cuff tubes & quick release connector

**HSP1239** seca b11 – 2 Tube with Adult Cuff

**HSP1240** seca b12 – 2 Tube as a set with size 3, 4, 5 cuff set

## seca b11/12 Manual BP Monitor

Versatility best describes the seca b11 because the large load cell is rotatable, so it can be used just as easily by right-handed as well as left handed users. The blood pressure monitor made of high-resistance polycarbonate is a preferred choice for hectic everyday practice due to its high impact resistance.

Another product advantage is the use of non-magnetizable materials so that it can be used even in highly sensitive MRI rooms. The robust exterior combines harmoniously with a high-precision measuring unit, giving the user the highest flexibility with impressive precision.

The seca b12 of identical construction simplifies daily work procedures with its thought-out combination of quick-release fastener and colour-coded tubes. This enables the cuff to be easily switched out. **Additional cuff sizes available.**

- No maintenance needed with simple exchange of load cell
- Made of non-magnetizable materials and Latex free
- Resistant to NHS cleaning agents, including Clinell
- Suitable for right and left handed users with rotatable load cell

## seca b10 Manual BP Monitor

Its high functionality and simple exchange of load cells make the seca b10 an especially versatile product.

It has a special device for hanging the load cell directly on the sleeve and can thereby be used just as easily by right-handed as well as left-handed users.

The product is decisively easier for frequent use in particular, due to the use of significantly fewer metal components. It demonstrates its improvement in efficiency not only through its low weight but also through its innovative technology. The user can easily exchange an old load cell for a new pre-calibrated cell, saving time and money. **Additional cuff sizes available.**

- No maintenance needed with a simple exchange of load cell
- Resistant to NHS cleaning agents, including Clinell
- The load cell and the control unit can be separated
- Suitable for right/left handed users with a rotatable load cell
- Latex free construction



**HSP1241** seca b10 with adult cuff

## seca b40/41 Manual BP Monitor

The seca b40 was designed as a tabletop model and stands out due to its excellent readability. The 140mm scale with anti-reflective glass offers the perfect view of all measurements from any perspective.

In combination with a three-meter-long cuff tube this gives the user the greatest freedom of use and always keeps the measurement results in view. The entire device is made of shatterproof polycarbonate and is therefore highly impact-resistant.

The seca b41 is the expandable basic model with the same large measuring scale. It offers the user full flexibility through three different usage options: Tabletop, Wall mounted, Rail mounted or with a mobile stand. **Additional cuff sizes available.**

- Overview - Perfect readability due to its 140 mm scale and anti-reflective glass
- Robust - Made of shatterproof polycarbonate and is therefore very impact-resistant
- Resistant to NHS cleaning agents, including Clinell
- Adjustable - The 3 meter cuff tube enables flexible work
- Latex free



**HSP1242** seca b40 – Tabletop with adult cuff

**HSP1244** seca b41w – Wall mounted with adult cuff

**HSP1245** seca b41r – Rail mounted with adult cuff

**HSP1246** seca b41s – Stand mounted with adult cuff

## Welch Allyn® 767 Aneroids

The versatile 767 Wall and Mobile Aneroid, with improved ergonomics and a new modern design, is the smart choice for accurate and reliable readings throughout your facility.

### Accurate

- Laser engraved dial face provides unmatched accuracy  
Certified accurate to +/- 3 mm Hg
- Recessed dial face and high contrast pointer increase visibility and reduce parallax errors

### Reliable

- Jeweled movement contributes to a longer life
- Lifetime calibration warranty
- 5 leg mobile stand provides stability and manoeuvrability
- Built in storage basket on wall and desk model

### Safe

- Latex & Mercury free

<b>HSP211</b>	Wall Aneroid with Adult Cuff
<b>HSP212</b>	Mobile Aneroid with Adult Cuff
<b>HSP213</b>	Desk Aneroid with Adult Cuff



## Welch Allyn® FlexiPort BP Cuffs

Affordable and easy to use, Welch Allyn FlexiPort Reusable Blood Pressure Cuffs offer all the advantages of FlexiPort technology, including simplified connectivity, with a dependable, durable, comfortable design.

- FlexiPort enables each cuff to be used as a one/two-tube cuff
- Tested to withstand demanding clinical environments
- Latex-free material minimizes risk of allergic reactions
- Rotatable port, improves patient comfort and cuff durability
- Meets all latest clinical guidelines for proper fit from AAMI and AHA
- Primary sizes are colour-coded to make it easy to find the proper cuff size

<b>HSP581</b>	Flexiport Small Child Cuff Size 8 (12-16cm)
<b>HSP582</b>	Flexiport Child Cuff Size 9 (15-21 cm)
<b>HSP583</b>	FlexiPort Cuff Small Adult Size 10 (20-26cm)
<b>HSP584</b>	FlexiPort Cuff Adult Size 11 (25-34cm)



<b>HSP590</b>	FlexiPort Single Tube Connector – 10 Pack
<b>HSP591</b>	FlexiPort Double Tube Connector – 10 Pack
<b>HSP589</b>	FlexiPort Adult Cuff Kit (Sizes 10 to 12L)
<b>HSP585</b>	FlexiPort Cuff Adult Long Size 11L (25-34cm)
<b>HSP586</b>	FlexiPort Cuff Large Adult Size 12 (32-43cm)
<b>HSP587</b>	FlexiPort Cuff Large Adult Long Size 12L (32-43cm)
<b>HSP588</b>	FlexiPort Cuff Thigh Size 13 (40-55cm)

## Welch Allyn® EcoCuffs Single Patient Use

Traditional single-patient-use cuff solutions can be expensive, wasteful, and difficult to implement. The innovative EcoCuff design helps surgeries reduce the risk of cross-contamination with technology that makes it simple to implement a single-patient-use cuff model, while at the same time helping to control costs and the surgery's environmental impact.

- Durable enough to last for prolonged patient treatment
- Features FlexiPort single-point connection system
- Slot fitting system helps prevent miscuffing
- Available in four sizes
- Meets all the latest clinical guidelines for proper fit from AAMI and AHA
- Up to 60% less environmental impact than traditional blood pressure cuffs
- Does not contain BPA, DEHP, Latex or PVC
- Capable of being recycled



<b>HSP594</b>	EcoCuff, Child (15-21 cm) - 10 Pack
<b>HSP595</b>	EcoCuff, Small Adult (20-28 cm) - 10 Pack
<b>HSP596</b>	EcoCuff, Adult (27-38 cm) - 10 Pack
<b>HSP597</b>	EcoCuff, Large Adult (33-45 cm) - 10 Pack
<b>HSP590</b>	FlexiPort Single Tube Connector – 10 Pack

# Welch Allyn® Durashock BP Series

The complete range of Welch Allyn hand held aneroid sphygmomanometers now incorporate shock-resistant DuraShock Technology that passes AAMI's shock resistant specification of surviving a 76 cm drop onto a hard surface whilst remaining in calibration.

With this technology you can count on these gauges to:

- Remain in calibration longer than traditional blood pressure gauges, providing you with accurate readings
- Not need to be replaced as often as traditional aneroids, giving you a lower lifetime cost

## Welch Allyn® Durashock DS55

- Thumbscrew air release valve fully Latex free
- Customisable name label for easy staff identification
- Shock-resistant movement
- Clinically validated to AAMI standards
- Supplied with a standard adult Flexiport™ cuff and soft case

HSP251 Durashock DS55 Black - Single tube

HSP252 Durashock DS55 Red - Single tube

HSP253 Durashock DS55 Yellow - Single tube

HSP254 Durashock DS55 Blue - Single tube



## Welch Allyn® Durashock DS54

- Thumbscrew air release valve
- Fully Latex free
- Shock-resistant movement (shock-resistant)
- Clinically validated to AAMI standards
- Supplied with a standard adult Flexiport™ cuff and soft case



See next page for WA BP Cuffs



HSP250 Welch Allyn® Durashock DS54

## Welch Allyn® Durashock DS58

- Gear-free DuraShock technology
- Exceeds AAMI's shock resistant requirement
- Jewel movement for long life
- Laser-engraved dial face for accuracy
- Premium inflation system for comfort fully Latex Free
- Ergonomic inflation bulb enhances user comfort
- Supplied with a standard adult Flexiport™ cuff and soft case



See next page for WA BP Cuffs



HSP210 Durashock DS58

## Welch Allyn® Durashock DS65

- Jewel movement for long life
- Trigger style air release valve fully Latex free
- Laser engraved dial for better accuracy
- Shock-resistant movement (shock-resistant)
- Clinically validated to AAMI standards
- Ergonomic design for added comfort and easy operation
- Supplied with a standard adult Flexiport™ cuff and soft case



See next page for WA BP Cuffs



HSP540 Durashock DS65

## Welch Allyn® Durashock DS66

- Trigger style air release valve
- Laser engraved dial for better accuracy
- Gear-free DuraShock technology
- Clinically validated to AAMI standards
- Ergonomic design for added comfort and easy operation
- Supplied with a standard adult Flexiport™ cuff and soft case
- Latex free



See next page for WA BP Cuffs



HSP541 Durashock DS66

## Riester e-mega BP Monitors

**Fast inflation of the cuff due to new ergonomic spoon design.**

- Lifelong precision due to almost non-aging precise movement
- Disinfectable and washable one-piece cuffs in different sizes
- Comfort - air release valve
- Specially hard copper-beryllium membrane resistant to aging
- Can withstand pressure loading up to 600 mm Hg
- Micro filter to protect release valve and measuring system
- Maximum error throughout range: +/-2mmHg



<b>HSP828</b>	e-mega White – 1 Tube with Obese Cuff & Soft case
<b>HSP829</b>	e-mega White – 1 Tube with Child Cuff & Soft case
<b>HSP830</b>	e-mega White – 1 Tube with Small Adult Cuff & Soft case
<b>HSP831</b>	e-mega White – 1 Tube with Adult Cuff & Soft case
<b>HSP832</b>	e-mega White – 1 Tube with Infant Cuff & Soft case
<b>HSP833</b>	e-mega White – 1 Tube with New Born Cuff & Soft case
<b>HSP834</b>	e-mega White – 1 Tube with Soft Case (No cuff)
<b>HSP835</b>	e-mega Black – 1 Tube with Adult Cuff & Soft case
<b>HSP836</b>	e-mega Black – 1 Tube with Obese Cuff & Soft case
<b>HSP837</b>	e-mega Black – 1 Tube with Small Adult Cuff & Soft case
<b>HSP838</b>	e-mega Black – 1 Tube with Child Cuff & Soft case
<b>HSP839</b>	e-mega Black – 1 Tube with Infant Cuff & Soft case
<b>HSP840</b>	e-mega Black – 1 Tube with New Born Cuff & Soft case
<b>HSP841</b>	e-mega Black – 1 Tube with Soft Case (No cuff)

## Riester big ben

- Large, easy to read sphygmomanometer designed for medical practices and hospital environments
- Choice of round or square housed in durable reinforced plastic
- Highly legible black aluminium scale 14.7 cm (square model 14.5 cm) with white markings and needle up to 300mmHg
- Roomy cuff basket for storage of accessories
- Coiled tube extends to a length of 3m
- Chrome plated air release valve with no stop pin
- Maximum error throughout range: +/-2mmHg
- Maximum reading: 300mmHg
- Standard version supplied with calibrated velcro adult cuff
- Cotton bandage and hook cuff versions available to order

<b>HSP028</b>	Riester big ben Desk (Round)
<b>HSP029</b>	Riester big ben Desk (Square)
<b>HSP030</b>	Riester big ben Wall (Round)
<b>HSP031</b>	Riester big ben Wall (Square)
<b>HSP032</b>	Riester big ben Mobile (Round) Powder Coated
<b>HSP033</b>	Riester big ben Mobile (Square) Powder Coated



<b>HSP029.1</b>	Riester big ben Velcro Cuff, Large adult
<b>HSP029.2</b>	Riester big ben Velcro Cuff, adult
<b>HSP029.3</b>	Riester big ben Velcro Cuff, child
<b>HSP028.3</b>	Connector for Riester big ben Cuffs

## HEINE® GAMMA® G5

Quality and durability of housing and spoon made of strong, impact resistant thermoplastic. The extra large insufflation bulb is comfortable to hold, enabling fast inflation of the cuff.

- Latex-Free & Shockproof
- Exclusive Pressure-Distribution System allows swift and precise readings and ensures a long manometer life.
- Pressure-Proof Manometer: Ensures durability and reliability. Corrosion-free materials.
- Micro-Filter: Protects valve and manometer.
- Large Diameter Scale: (56mm) is easy to read.
- Large Insufflation Bulb: 50% larger volume for fast inflation.
- Precision Air-Release Valve: Provides fine and precise air-release rate adjustment, quick deflation, and extreme durability. A rubber-stop prevents valve-lock.
- Housing is moulded of shockproof plastic with shock-absorbing, anti-slip coating.
- Adjustable Spoon for both right or left-handed operation.



<b>HSP1164</b>	GAMMA G5 With Adult Cuff
<b>HSP1165</b>	GAMMA G5 With Child Cuff
<b>HSP1166</b>	GAMMA G5 Practice Kit with 3 Cuffs
<b>HSP1167</b>	GAMMA G5 With Adult Cuff - Pouch 10pk
<b>HSP1168</b>	Single Tube Cuff - Child Small
<b>HSP1169</b>	Single Tube Cuff - Child
<b>HSP1170</b>	Single Tube Cuff - Adult Small
<b>HSP1171</b>	Single Tube Cuff - Adult
<b>HSP1172</b>	Single Tube Cuff - Large Adult

## HEINE® GAMMA® G7

Aluminium alloy construction & precision valve.



10 Year  
Warranty

The GAMMA G7 is unique in its advanced construction, utilising a housing made of aluminium alloy and advanced thermoplastics, producing a shockproof and modern design.

**Combines all design and quality features of the G5, except:**

- Upper Housing made of aluminium alloy with a shock-absorbing ring protecting indicator and glass.
- Lower Housing is moulded of shockproof plastic with shock-absorbing, anti-slip coating.
- Light Alloy, Adjustable Spoon: For both right- or left-handed operation.
- A longer 10 year warranty



<b>HSP1173</b>	GAMMA G7 With Adult Cuff
<b>HSP1174</b>	GAMMA G7 With Child Cuff
<b>HSP1175</b>	GAMMA G7 Practice Kit with 3 Cuffs
<b>HSP1176</b>	GAMMA G7 With Adult Cuff - Pouch 10pk

**Heine GAMMA Cuffs:**

<b>HSP1168</b>	Single Tube Cuff - Child Small
<b>HSP1169</b>	Single Tube Cuff - Child

## HEINE® GAMMA® GP

Standard Instrument with Push-Button Valve.



5 Year  
Warranty

Equipped with an innovative, absolutely reliable and easy-to-operate push-button valve, the new GAMMA GP combines all the design and quality features of the tried and proven GAMMA G5.

- Innovative Push-Button Valve.
- Fine and precise air-release rate adjustment, ultra-fast air-release, practically wear-free.
- Easy to operate by both left- and right-handed users.



<b>HSP1177</b>	GAMMA GP With Adult Cuff
<b>HSP1178</b>	GAMMA GP With Child Cuff
<b>HSP1179</b>	GAMMA GP Practice Kit with 3 Cuffs
<b>HSP1180</b>	GAMMA GP With Adult Cuff - Pouch 10pk

<b>HSP1170</b>	Single Tube Cuff - Adult Small
<b>HSP1171</b>	Single Tube Cuff - Adult
<b>HSP1172</b>	Single Tube Cuff - Large Adult

## HEINE® GAMMA® XXL LF Sphygmomanometer

**The versatile professional model.**

The Classic GAMMA XXL LF comes in a latex-free (LF) version with a range of mounting options that makes it the ideal sphygmomanometer in any clinical setting.

The oversized, adjustable scale is easy to read, even from a distance. Since the GAMMA XXL LF is non-mercurial, it is both safe and environmentally-friendly.

- Latex-Free.
- Durable Polycarbonate Construction will hold up in the busiest hospital and practice environments.
- Oversized 130 mm diameter scale can be pivoted for clear, easy reading from any angle.
- Long Spiral (3m) Inflation Tube for increased working distance.
- High Quality Indicator is precisely calibrated and durable.
- Precision Air-Release Valve made of metal.
- Pressure-Proof Manometer: Ensures durability and reliability.
- Mercury-free. Environmentally friendly.
- **Wall, Desk, Rail and Wheeled Stand** (with adjustable height) Mounting Options.

<b>HSP1185</b>	GAMMA XXL Cuff - Child Small
<b>HSP1186</b>	GAMMA XXL Cuff - Child
<b>HSP1187</b>	GAMMA XXL Cuff - Adult Small
<b>HSP1188</b>	GAMMA XXL Cuff - Adult
<b>HSP1189</b>	GAMMA XXL Cuff - Large Adult
<b>HSP1192</b>	Universal Mounting Plate for Rail, Wall or Wheeled



<b>HSP1181</b>	GAMMA XXL LF-W Wall Model
<b>HSP1182</b>	GAMMA XXL LF-S Wheeled Stand Model
<b>HSP1183</b>	GAMMA XXL LF-R Rail Model
<b>HSP1184</b>	GAMMA XXL LF-T Desk Model
<b>HSP1183.1</b>	GAMMA XXL LF-WB for Wallboard
<b>HSP1190</b>	Cuff Holder for Desk Mount GAMMA® XXL LF-T
<b>HSP1191</b>	Desk Stand for Desk Mount GAMMA® XXL LF-T
<b>HSP1193</b>	Rail Clamp for GAMMA® XXL LF-R
<b>HSP1194</b>	Adjustable Wheeled Stand for GAMMA® XXL LF-S
<b>HSP1183.2</b>	Wallboard for GAMMA XXL-W
<b>HSP1183.3</b>	Wallboard for GAMMA XXL-WB

## ACCOSON™ Nursing Stethoscope

Our ACCOSON™ Nursing Stethoscope is a Lightweight Aluminium Stethoscope offering an effective and elegant solution for day-to-day nursing.

- Extra fine acoustic response and super light design for extraordinary comfortable.
- The adult chestpiece precisely machined to exacting tolerance from lightweight aluminium.
- Double leaf internal spring binaurals are fixed at 15° angle for the comfortable ear fit.
- Available in your preferred choice of three tubing colours
- Supplied with an extra set of soft sealing eartips and diaphragm.
- Overall length 770 mm.

<b>HST779</b>	Nursing Stethoscope with Black Tubing
<b>HST779.1</b>	Nursing Stethoscope with Navy Blue Tubing
<b>HST779.2</b>	Nursing Stethoscope with Burgundy Tubing



## ACCOSON™ Physician Stethoscope

Offering Rugged Durability combined High Acoustic Response, the ACCOSON™ Physicians Stethoscope is perfect for both hospital doctors and GP's.

- Superior acoustic response and rugged durability.
- The chestpiece is precisely machined to exacting tolerance from surgical stainless steel for outstanding performance.
- Available in your preferred choice of three tubing colours
- The unit comes in a foam lined box with two extra sets of soft sealing eartips and one diaphragm.
- Overall length 770 mm

<b>HST780</b>	Physician Stethoscope with Black Tubing
<b>HST780.1</b>	Physician Stethoscope with Navy Blue Tubing
<b>HST780.2</b>	Physician Stethoscope with Burgundy Tubing

## ACCOSON™ Cardiology Stethoscope

Manufactured from the finest stainless steel the ACCOSON™ Cardiology Stethoscope offers medical professionals one of the highest quality stethoscopes currently available on the market.

- Combination of adult and convertible paediatric chestpiece for optimized acoustic sensitivity
- Dual tunable diaphragm for monitoring high and low frequencies
- Extra adult bell for low frequency response
- The chestpiece is precisely machined to exacting tolerance from stainless steel
- Available in your preferred choice of three different tubing colours
- Space alloy binaural assembly with dual lumen tubing
- Non-chill ring provides patient comfort
- Silicon soft-sealing eartips
- Overall length 700 mm.

<b>HST781</b>	Cardiology Stethoscope with Black Tubing
<b>HST781.1</b>	Cardiology Stethoscope with Hunters Green Tubing
<b>HST781.2</b>	Cardiology Stethoscope with Burgundy Tubing







**Choose the right stethoscope to help you perform at your best.**

3M™ Littmann® Stethoscopes feature adjustable headsets with soft-sealing eartips. Select Littmann mechanical stethoscopes are designed with tunable technology to give you the ability to hear different frequency sounds by simply adjusting the pressure applied to the chestpiece. Get the acoustic performance, high quality and comfort you need with a Littmann stethoscope.

	ACOUSTIC PERFORMANCE LEVELS						
	6	7-8		9-10		10+	
	<b>Lightweight II S.E. Stethoscope</b>	<b>Classic II Paediatric and Infant Stethoscopes</b>	<b>Master Classic II™ Stethoscope</b>	<b>Classic III™ Monitoring Stethoscope</b>	<b>Cardiology IV™ Diagnostic Stethoscope</b>	<b>Master Cardiology™ Stethoscope</b>	<b>CORE Digital Stethoscope</b>
	Ideal for taking blood pressure readings and making limited patient assessments.	Hard-working, dependable, clinical tools for physical assessment and monitoring of your patients, one long shift after another.			Provides outstanding acoustic sensitivity to help you perform detailed diagnostic auscultation. Useful in challenging and critical care environments.		High-performance auscultation. Hear more with amplification, noise cancellation and mobile connectivity.
<b>Approximate Length</b>	71cm	71cm	69cm	69cm	69cm	69cm	69cm
<b>Approximate Weight</b>	118g	105g, 95g	160g	150g	177g	185g	232g
<b>Warranty</b>	2 years	3 years	3 years	5 years	7 years	7 years	2 years
<b>Diaphragm</b>	Tunable	Non-Tunable (Floating)	Tunable	Tunable (2)	Tunable (2)	Tunable	Tunable (2)
<b>Approximate Chestpiece Diameter</b>	Double-sided 5.2 x 4.5cm 3.5 x 3.2cm	Double-sided Paediatric 3.4cm 2.7cm Infant 2.8cm 1.7cm	Single-sided 4.3cm	Double-sided Adult side 4.3cm Paediatric side 3.4cm	Double-sided Adult side 4.3cm Paediatric side 3.4cm	Single-sided 4.8cm	Double-sided Adult side 4.3cm Paediatric side 3.4cm
<b>Features</b>	Teardrop-shaped chestpiece Fits under blood pressure cuff	Specially designed for the smallest patients	Designed for easier grip and maneuvering	Convertible open bell	Convertible open bell Dual-lumen tubing	Dual-lumen tubing Best acoustic response in Littmann mechanical line	Up to 40x amplification* Switch from analog listening to digital Connects to Eko software on a smart device** to capture, store and share data

The power to learn, in the palm of your hand. 3M™ Littmann® Learning Institute App – Free with purchase of a 3M™ Littmann® Stethoscope!

\*At peak frequency, vs. analogue mode  
\*\*Not included

**3M™ Littmann® Classic III Monitoring**

With a two-sided chestpiece, dual tunable diaphragms and improved tubing, the Classic III combines new and traditional. Offering high acoustic sensitivity for exception performance when doing general physical assessment. The two-sided chestpiece features tunable diaphragms on both the large and small sides for greater versatility.

- **Tunable diaphragms** on both the adult and paediatric sides. The paediatric side is useful for smaller patients etc.
- **Open bell** stays clear of dirt and debris by covering it with the small diaphragm
- **No natural rubber latex** or phthalate plasticisers are used in the tubing or any other component
- **Next-generation tubing** lasts longer with improved resistance to skin oils and alcohol; less likely to pick up stains
- **Single-piece diaphragm** is easy to attach and easy to clean because the surface is smooth without crevices

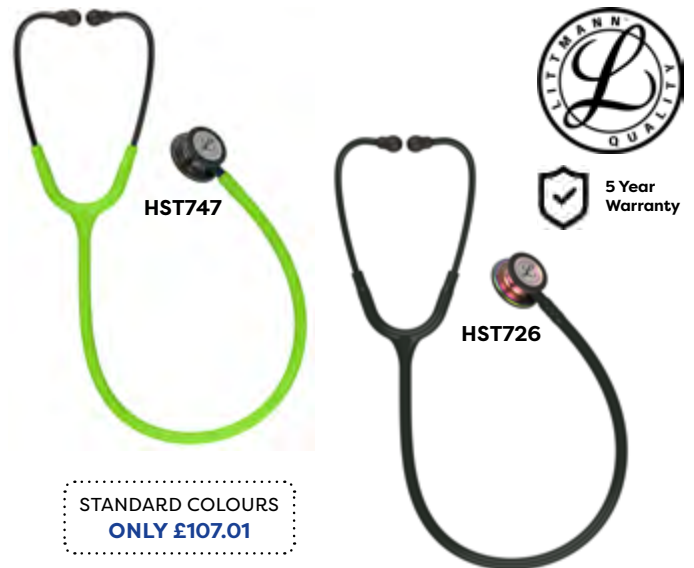

STANDARD COLOURS ONLY £107.01

<b>HST650</b> Black		<b>HST624</b> Caribbean Blue		<b>HST653</b> Burgundy		<b>HST671</b> Pearl Pink	
<b>HST651</b> Navy Blue		<b>HST670</b> Ceil Blue		<b>HST656</b> Lemon-Lime		<b>HST672</b> Plum	
<b>HST654</b> Lavendar		<b>HST655</b> Turquoise		<b>HST675</b> Grey		<b>HST777</b> Raspberry	

**Special Edition Stethoscope Versions:**

<b>HST658</b> Black Chestpiece & Black Tube Edition	<b>HST659</b> Copper Chestpiece & Chocolate Tube Edition
<b>HST724</b> Black Chestpiece & Burgundy Tube Edition	<b>HST678</b> Rainbow Chestpiece & Raspberry Tube Edition
<b>HST736</b> Champagne Chestpiece & Black Tube Edition	<b>HST679</b> Rainbow Chestpiece & Caribbean Blue Tube Edition
<b>HST739</b> Champagne Chestpiece & Burgundy Tube Edition	<b>HST726</b> Rainbow Chestpiece & Black Tube Edition
<b>HST738</b> Mirror Chestpiece & Navy Blue Tube Edition	<b>HST680</b> Smoke Chestpiece & Black Tube Edition
<b>HST766</b> Mirror Chestpiece, Ceil Blue Tube & Smoke Stem	<b>HST744</b> Smoke Edition, Turquoise Tube & Pink Stem
<b>HST767</b> Mirror Chestpiece, Plum Tube & Pink Stem	<b>HST745</b> Smoke Edition, Gray Tube & Violet Gray Stem
<b>HST768</b> Mirror Chestpiece, Pearl Pink Tube & Pink Stem	<b>HST747</b> Smoke Edition, Lime Green Tube & Blue Stem

## 3M™ Littmann® Cardiology IV Diagnostic

The next generation of the most recognised stethoscopes in the profession, offering improved acoustic performance with better audibility of high-frequency sounds (adult side, firm pressure).

Its distinctive chalice-shaped chestpiece features tunable diaphragms on both sides to deliver outstanding acoustic performance, diagnostic versatility, and convenience for treating adult and paediatric patients. The paediatric side of the chestpiece converts to an open bell by removing the tunable diaphragm and replacing with the included non-chill bell sleeve.

- **Tunable diaphragm:** Hear high or low frequency sounds by slightly adjusting pressure on the chestpiece
- **Dual-lumen durable tubing:** Two sound paths in one tube eliminates the rubbing noise of traditional double tubes
- Not manufactured with neither natural rubber latex or phthalate plasticizers
- Headset is easily adjusted for individual fit and comfort
- Angled eartubes align with ear canals
- Next-generation tubing lasts longer and resists stains. Not made with natural rubber latex or phthalate plasticizers.
- Expect strong performance with a 9+ rating on a 1-10 scale
- Seven-year warranty provides greater peace of mind.

### Special Edition Stethoscope Versions:

<b>HST763</b>	High Polish Rainbow, Black Tub & Smoke Stem
<b>HST764</b>	High Polish Rainbow, Raspberry Tube & Smoke Stem
<b>HST765</b>	High Polish Rainbow, Navy Tube & Black Stem
<b>HST708</b>	Rainbow Chestpiece & Black Tube Edition
<b>HST753</b>	Rainbow Edition, Plum Tube & Violet Stem
<b>HST734</b>	Mirror Chestpiece & Black Tube Edition
<b>HST735</b>	Champagne Chestpiece & Black Tube Edition
<b>HST741</b>	Champagne Chestpiece & Burgundy Tube Edition
<b>HST710</b>	Black Chestpiece & Navy Blue Tube Edition



STANDARD COLOURS  
ONLY £220.07

<b>HST697</b>	Black		<b>HST699</b>	Navy Blue	
<b>HST701</b>	Plum		<b>HST703</b>	Raspberry	
<b>HST700</b>	Hunter Green				

<b>HST706</b>	Black Edition, Black Chestpiece & Tubing
<b>HST748</b>	Black Edition, Black Tube & Red Stem
<b>HST749</b>	Black Edition, Black Tube & Blue Stem
<b>HST751</b>	Black Edition, Black Tube & Violet Stem
<b>HST750</b>	High Polish Smoke Edition & Navy Tube, Blue Stem
<b>HST760</b>	High Polish Smoke, Black Tube & Black Stem
<b>HST761</b>	High Polish Smoke, Caribbean Tube & Mirror Stem
<b>HST762</b>	High Polish Smoke, Gray Tube & Smoke Stem
<b>HST752</b>	High Polish Smoke Edition, Black Tube & Champagne Stem

## 3M™ Littmann® CORE Range

Features the outstanding acoustics, comfort and quality of a Littmann cardiology-grade stethoscope enhanced by powerful digital technology.

Features such as up to 40x amplification and active noise cancellation can help you auscultate with greater confidence. Connects with Eko software on a smart device to visualize, record and share data.

Hold the chestpiece with light pressure on the patient to hear low frequency sounds; press a little more to hear higher frequency sounds. Soft-sealing ear tips conform to individual ears for optimal comfort and excellent sound occlusion.

- Connects to Eko software to visualize and share heart sound waveforms
- Up to 40x amplification (at peak frequency, vs. analog mode)
- Active noise cancellation reduces unwanted background sounds
- Toggle between analog and amplified listening modes
- Soft-sealing ear tips provide an excellent acoustic seal and comfortable fit
- Tunable, dual-sided stainless steel chestpiece with open or closed bell
- Designed for use with adult and pediatric patients
- FDA-cleared and HIPAA compliant
- Applications: Cardiology/High Performance



<b>HST101</b>	Black Edition, Black Tube & Stem
<b>HST101.1</b>	High Polish Rainbow Chestpiece & Black Tube
<b>HST101.2</b>	High Polish Copper Chestpiece & Black Tube
<b>HST101.3</b>	Mirror Chestpiece & Black Tube

## 3M™ Littmann® Master Cardiology

Characterized by the best acoustic response in the Littmann mechanical stethoscope line; with a tunable diaphragm, dual-lumen tubing, and a precision, ergonomically designed, stainless steel chestpiece.

Headset tension is easily adjusted for head size and comfort by squeezing together or pulling apart the eartubes. Snap-tight, soft-sealing eartips conform to individual ears for an excellent acoustic seal and comfortable fit.

- Handcrafted, solid stainless steel chestpiece
- Outstanding acoustic quality
- Single-sided diaphragm for high and low frequencies
- Double lumen tubing
- Adaptor for difficult site and paediatric auscultation
- Non-chill rim

### Special Edition Stethoscope Versions:

<a href="#">HST035.4</a>	(Black Edition) Black Chestpiece & Tubing
<a href="#">HST627</a>	Smoke-Finish Chestpiece & Black Tube Edition
<a href="#">HST632</a>	Brass Chestpiece & Black Tube Edition



<a href="#">HST032</a>	Black		<a href="#">HST035.1</a>	Plum	
<a href="#">HST035</a>	Navy Blue		<a href="#">HST033</a>	Burgundy	

## 3M™ Littmann® Paediatric

Designed for use on smaller patients. It delivers high acoustic sensitivity, via two-sided chestpiece, for high and low frequency.

- Designed, sized and acoustically perfected, specifically for children and younger patients
- Non-chill rim and diaphragm provide patient comfort
- Latex-free materials accommodate allergy sensitive users
- Soft-sealing eartips provide an excellent acoustic seal and comfortable fit.
- Single lumen tubing

<a href="#">HST017.1</a>	Raspberry		<a href="#">HST017.6</a>	Red	
<a href="#">HST017.2</a>	Caribbean Blue		<a href="#">HST017</a>	Black	

### Special Edition Stethoscope Version:

<a href="#">HST017.RCB</a>	Rainbow Finish Chestpiece & Caribbean Blue Tube Edition
----------------------------	---



## 3M™ Littmann® Infant

Designed for use on the smallest patients. It delivers high acoustic sensitivity, through its dual-sided chestpiece, for both high and low frequency.

Used by medical professionals and students alike to identify, listen to, and study heart, lung, and other body sounds for physical assessment and diagnosis in infants.

- Dual-sided chestpiece with small 2.7cm diaphragm is ideal for paediatric patients.
- Traditional two-sided chestpiece with bell/diaphragm
- Designed, sized, coloured and acoustically perfected, specifically for infants
- Floating diaphragm
- Non-chill rim
- Single lumen tubing

### Special Edition Stethoscope Version:

<a href="#">HST017.RE</a>	Rainbow Finish Chestpiece & Raspberry Tube Edition
---------------------------	--







<a href="#">HST017.3</a>	Black		<a href="#">HST017.RED</a>	Red	
<a href="#">HST017.CB</a>	Caribbean Blue				

## 3M™ Littmann® Lightweight II SE

This general-purpose, entry-level stethoscope is an excellent, affordable choice for blood-pressure and patient assessment.

Littmann quality is apparent from the soft-sealing eartips to the combination bell/diaphragm chestpiece.

- Switch from low to high frequency by simply adjusting between firm pressure and light pressure – 3M's 'Tunable Technology'
- Littmann® unique shaped chestpiece for easy of use.
- Ergonomically designed headset and eartips for comfortability and to ensure the perfect positioning. These also ensure a great acoustic seal, reducing ambient noise.
- Double-sided chestpiece gives you the option of a tunable diaphragm on the front or a traditional bell on the reverse.
- Ovoid chestpiece with offset bell for better orientation around blood-pressure cuffs and body contours

<b>HST629</b>	Burgundy		<b>HST628</b>	Black	
<b>HST630</b>	Ceil Blue		<b>HST639</b>	Pearl Pink	
<b>HST641</b>	Caribbean Blue				



## 3M™ Littmann® Spare Parts

3M™ Littmann® Stethoscopes offers the high quality that medical professionals expect, and each replacement part and accessory meets the same demanding standards.

Conveniently packaged in kits that correspond to our stethoscope models, Littmann stethoscope replacement parts and accessories make repairs simple. Each item is carefully manufactured to work seamlessly with existing equipment.

**Each kit includes:** Replacement eartips and diaphragm(s)

<b>HST682</b>	Stethoscope Kit – Classic II S.E., Black, 40005	<b>£22.44</b>
<b>HST683</b>	Stethoscope Kit – Classic II S.E., Grey, 40006	<b>£22.44</b>
<b>HST687</b>	Stethoscope Kit – Classic II Pediatric Diaphragm, 40012	<b>£13.81</b>
<b>HST688</b>	Stethoscope Kit – Classic II Infant Assembly, 40013	<b>£13.81</b>
<b>HST685</b>	Stethoscope Kit – Classic III, Black, 40016	<b>£22.44</b>
<b>HST693</b>	Stethoscope Kit – Classic III, Grey, 40017	<b>£22.44</b>



<b>HST690</b>	Stethoscope Kit – Lightweight II S.E., Black, 40020	<b>£18.12</b>
<b>HST691</b>	Stethoscope Kit – Lightweight II S.E., Light Brown, 40021	<b>£18.12</b>
<b>HST692</b>	Stethoscope Kit – Master Cardiology, Black, 40011	<b>£18.12</b>
<b>HST694</b>	Stethoscope Kit – Master Cardiology, Grey, 40018	<b>£18.12</b>
<b>HST695</b>	Stethoscope Kit – Master Classic, Black, 40022	<b>£18.12</b>
<b>HST696</b>	Stethoscope Kit – Master Classic, Grey, 40023	<b>£18.12</b>

## 3M™ Littmann® ID Tags

Fits all sizes of 3M™ Littmann® Stethoscopes, perfect to personalise/identify your own stethoscope. Available in both Black and Grey.

- I.D. tag provides easy identification of stethoscope
- Includes one write-on and one engraving name plate
- Personalise your stethoscope
- Fits all models



<b>HST728</b>	Black Tag 40007	<b>£5.18</b>
<b>HST729</b>	Grey Tag 40008	<b>£5.18</b>

## 3M™ Littmann® Soft Eartips

Snap-tight, soft-sealing eartips conform to individual ears for an excellent acoustic seal and comfortable fit. Eartips snap firmly onto the ends of the eartubes and, for safety, require a significant effort to remove.

- Quality and reliability in one convenient package
- Replacement of the eartips on all Littmann stethoscopes



<b>HST730</b>	Snap Tight Soft-Sealing, Large and Small – Black 40001	<b>£13.81</b>
<b>HST731</b>	Snap Tight Soft-Sealing, Large and Small – Grey 40002	<b>£13.81</b>

## seca s10 Stethoscope

With its low weight, the seca s10 is the ideal partner for use in a wide range of applications. But no compromises were made for a balanced acoustic image with this lightweight and inexpensive model with a thinner tube and smaller chest piece.

The reversible double-sided chest piece with membrane side and bell side enables the nuanced auscultation of high and low-frequency sounds. Aided by the convex pre-stressed membrane that lies perfectly on the skin for optimal sound transmission.

The optimal reproduction adapts to each individual through its integrated yoke spring.

- Ear clips- Custom adaptation through integrated yoke spring
- Economical - Optimal price to performance ratio
- Handling - Especially lightweight model
- Resistant to NHS cleaning agents, including Clinell

HST713      seca s10 Stethoscope

**seca**

2 Year  
Warranty



C

Stethoscopes

## seca s30/32 Two Channel Stethoscope

The dual construction of the chest piece picks up low as well as high frequencies frequently, making the seca s 30 the perfect choice for physicians with varying daily demands.

The smaller of the two membrane sides can be used to precisely auscultate even difficult-to-reach locations. The stethoscope tube has two inner channels to reduce sound loss to an absolute minimum. The separately integrated spring in the tube also ensures sound transmission without interference.

The seca s 32 is tailored to physicians with primarily younger patients. The double-sided chest piece has a child-friendly design on the large membrane side and the smaller side is particularly well suited for infants or thin patients.

- Acoustics: The side of the chest piece that is not required can be switched off to minimize background noise.
- Membrane sides: Different sides for listening to different regions of the body.
- Double-tube system: Two parallel channels in the stethoscope tube for optimal sound wave transmission.
- Resistant to NHS cleaning agents, including Clinell



HST715      seca s30 Two Channel Stethoscope

HST720      seca s32 Two Channel Stethoscope

## seca s20/22 Two Channel Stethoscope

The seca s 20 has versatile applications with its reversible double-sided chest piece and is thereby the ideal all-round talent for a reliable first analysis. Whether listening to the heart (membrane side) or lungs (bell side), simply reverse the chest piece to switch on the respective range and minimize background noise.

The child-friendly design on the membrane side of the double-sided chest piece makes the seca s22 a stethoscope that is especially suitable for the auscultation of children to infants. This simplifies contact with smaller patients without causing fear. It is suitable for the auscultation of infants to children.

- Reversible doublesided chest piece - Membrane and bell side for the widest variety of demands
- Membrane - The convex prestressed membrane enables excellent resonance transmission with optimal skin contact
- Resistant to NHS cleaning agents, including Clinell
- Two-channel tube - With separately integrated yoke spring for lossless sound transmission



HST714      seca s20 Two Channel Stethoscope

HST719      seca s22 Pediatric Two Channel Stethoscope

## seca s40 Two Channel Stethoscope

A premium quality stethoscope, for a highly differentiated listening experience. The heaviness of the chest piece ensures accurate acoustics, particularly on patients lying down.

Using the resonance chamber lying in the dual membrane, the sound can be amplified and the frequency range can be shifted. The chestpiece lies perfectly on the skin to reduce background noise.

- Chest piece - Its net weight ensures optimal skin contact and minimizes background noise
- Sound quality - The dual membrane forms a resonance chamber for brilliant acoustics
- Insulation ring - Improves comfort for sensitive patients
- Resistant to NHS cleaning agents, including Clinell



HST716 seca s40 Two Channel Stethoscope

## seca s50 Two Channel Stethoscope

With double-sided construction, each side reproduces a defined frequency spectrum for an optimal listening experience.

bell side is optimal for pneumology because it primarily picks up sounds in low frequencies. A membrane side reproduces an entire frequency range including higher frequencies through its technically demanding dual membrane.

- Double-sided chest piece - Reversible with a dual membrane side and a bell side. Ideal for pneumology and cardiology
- Acoustics - The side of the chest piece that is not required can be switched off to minimize background noise
- Resistant to NHS cleaning agents, including Clinell
- Two-channel tube - Delivers a sound pattern that transmits even the most subtle sounds without loss



HST717 seca s50 Two Channel Stethoscope

## seca s60 Two Channel Stethoscope

For perfect auscultation the dual membrane reproduces the entire frequency range of low and high frequencies. A sophisticated procedure not only transmits the sound on the plastic membrane but also amplifies it in a resonance chamber.

The membrane is suspended and adapts perfectly to any surface, preventing the transmission of background noise. The ergonomic design of the ear clips increases their comfort and the two inner channels transmit the sound without loss.

- Hygiene: Highly polished, non-porous chrome-plated brass
- Ergonomic: Perfect handling due to the specially tailored head shape of the chest piece
- Resistant to NHS cleaning agents, including Clinell
- Dual membrane: forms a resonance chamber to amplify sounds

HST718 seca s60 Two Channel Stethoscope



## Riester duplex Teaching Stethoscope

Double chest-piece and two matt chromium plated binaural has been developed especially for teaching purposes.

- Special membrane: Ø 48 mm (1.89 in), with particularly flat and soft non-chill rims for improved adaptation on the skin
- Bell, Ø 36 mm (1.42 in)
- Overall length: 115 cm (45.28 in)
- Supplied with 2x extra pairs of ear-tips & 1x extra membrane



HST759 duplex Teaching Stethoscope

## Nurses Stethoscope

The deluxe nurse's stethoscope is an economical option for reviewing auscultation in any environment

- Single or dual Head
- 3 Differing variations
- Designed for nurse use
- Economical option for use
- Available in a range of colours (Please contact us for info)
- CE Marked



HST059 Nurses Deluxe - Dual Head

## Surgical Instruments

We stock a comprehensive range of surgical instruments, designed for medical professional environments. We can supply more common items such as forceps, scissors and probes through to complete surgery packs and specialist equipment.

- Surgical forceps and scissors
- Complete surgery packs
- Full instrument sets
- Probes, scoops & seekers

Contact our helpful sales team for assistance with your requirements. See our product range online:

[www.hce-uk.com/consumables](http://www.hce-uk.com/consumables)

- Needle & towel holders
- Swabs & wipes
- Scalpel blades & handles
- Gynaecology equipment



View this range online at: [www.hce-uk.com/surgical-instruments](http://www.hce-uk.com/surgical-instruments)



## SMART Resuscitation Trainer

Designed to help individuals who may be called upon to resuscitate babies or young children, to learn or improve, mask ventilation technique. This forms part of the UK Resuscitation Council's Advanced Resuscitation of the Newborn Infant (ARNI) course, and can also be used for ongoing practice, for self or observed certification, or for research purposes.

The SMART resuscitation trainer provides objective and immediate feedback on face mask ventilation technique; in terms of mask leak and other factors.

- **There are two versions available:**  
Standard (ARNI) designed for use in the UK Resuscitation Councils and the Advanced (Training/Research).

Both systems provide risk free practice, enabling adjustment of an individual's technique to establish a stable, comfortable and reproducible technique.

- **The Advanced (Training/Research)** adds the capability of a practice session prior to moving on to a certification session and creation of a certificate. Respiratory traces, leakage rates and raw data can be saved and recalled for processing.
- Both the Standard (ARNI) and the Advanced (Training/Research) models are supplied with a modified Preterm and Term Manikin, the Child Manikin can be purchased as an optional extra.

AE1792	SMART Standard (ARNI)
AE1793	Smart Advanced (Research/Training)
AE1794	Modified Preterm Manikin
AE1795	Modified Term Manikin
AE1796	Modified Child Manikin
AE1797	Set of Masks/Laptop Package



## Baby Neonatal Intubation Trainer

Laerdal Neonatal Intubation Trainer allows teaching of intubation skills for use on a newborn baby.

A trainer for airway management skills on the newborn baby.

Robust and realistic this model allows students to undertake airway skills training that are directly transferable to the clinical setting.

- Realistic Anatomy of newborn
- Endotracheal, oral and nasal intubation
- Anatomical landmarks and Simulated lungs
- Bag-Value-Mask Ventilation
- Correct tube placement can be checked by practical inflation test
- Transparent protective manikin cover
- Mounted on a base with Silicone spray included

### Supplied with:

- 1 Neonatal Infant Head and Upper Torso
- 1 Can of Manikin Lubricant
- 1 Base with Transparent Cover
- Directions for Use

AE275	Baby Neonatal Intubation Trainer
-------	----------------------------------





## Mini Anne Plus

This little manikin has all the requirements for a Quality CPR course in one convenient, portable, reusable kit. Open the bag and start your training in no-time.

Mini Anne Plus has proven to efficiently deliver high quality CPR training for large groups and classroom situations. Millions of school children have learned CPR globally through the use of the manikin.

### Correct compression depth

Hear that compressions are done correctly, in line with the international CPR guidelines.

### Hygienic and clean

Fast, easy and clean – Mini Anne Plus comes with face wipes and a replaceable lung which can be changed between classes.

### Minimal preparation

Set up classes in minutes. The Mini Anne Plus kits comes with training mats and a new innovative pump bag, allowing students to inflate their own manikin.

### Quality guaranteed

Perform over 300 000 compressions on a Mini Anne Plus. One training session can reach 500 compressions per manikin.

### Affordable consumables

Buy new face wipes and lungs from our online shop. You can also buy a single manikin if one needs to be replaced, or if you need to expand your classroom kit.

- Reusable set of 10 Mini Anne manikins
- Durable tested to at least 300,000 compressions
- Easy-to-use pump bag for hygienic inflation
- Guidelines compliant clicker setting
- Soft clicker setting encourages new learners
- Supplied with carry bag including pump bag & kneel mats for each student
- Quick preparation and clean up



AE270	Mini Anne Plus Unicolour - 10pk
AE270.2	Manikin Mini Anne Plus single
AE270.6	Airway Assembly Mini Anne Plus – 5pk
AE270.7	Faces Mini Anne Plus Dark Skin – 5pk
AE270.8	Faces Mini Anne Plus Light Skin – 5pk
AE267.4	Manikin Wipes (50)

## Little Family QCPR Pack

The recently updated Little Family Pack from Laerdal now includes one Little Anne QCPR, one Little Junior QCPR, and one Little Baby QCPR and a large bag on wheels to carry the pack.

This offers the opportunity to include objective QCPR feedback within your CPR training for a range of different ages groups.

QCPR Technology is utilized to enable both instructors and trainees to more effectively monitor and review performance, increasing the efficiency and value of training time.

The Little Family Pack is an all-in-one, realistic and inexpensive training solution, designed to reflect the realistic anatomical differences between an adult, a child and an infant.

### Compatible with Free Laerdal QCPR Instructor & Learner Apps

- The instructor app gives a performance overview of up to six manikins, simultaneously. Ensuring effective coaching.
- The learner app allows practice alone. Multiple learners can also use the app to coach each other.

AE1828 Little Family QCPR – Light Skin

AE1829 Little Family QCPR – Dark Skin



## Resusci Junior Q CPR

Q CPR Technology is utilized to enable both instructors and trainees to more effectively monitor and review performance, increasing the efficiency and value of training time.

Conducting CPR on a child is a rare occurrence, so learning how it feels to perform CPR correctly is important to maximize the chance of survival during those critical moments of a child's resuscitation.

### This enables you to:

- More effectively facilitate training for individuals and high-performance teams
- Train in any environment of your choice
- Assess the performance results of individuals in real-time
- Provide a team debrief while also focusing on individual performances

### This product also features:

- Improved compression mechanism - humanlike and stable
- Guidelines 2015 compliant - compression depth 50-60 mm
- Realistic ventilation for bag valve mask and mouth to mouth - chest rise, neck tilt and optional audible feedback
- New electronics - Bluetooth Low Energy (BTLE) and sensors
- Battery operated, can also be used with mains power
- Training mat - doubles as carrying bag

AE1766 Resusci Junior Q CPR



## Little Anne Q CPR Manikin

Improved CPR training quality and learner engagement for bystanders and first-aid workers. Includes a gaming element and feedback technology. This helps instructors improve both CPR training quality, classroom efficiency and learner engagement.

- Uses Bluetooth smart technology connecting with tablets and smartphones to deliver Q CPR feedback
- Oral and nasal passages allow realistic nose pinch
- Airway obstruction for training of opening airway technique
- Head tilt/chin lift and jaw thrust allow students to correctly practice all manoeuvres necessary when resuscitating a victim
- Realistic airway function means that the airway remains obstructed without proper head tilt/chin lift or jaw thrust.
- Anatomically correct landmarks and sternal notch allow the student to practice identification of all relevant landmarks
- Audible feedback reinforces correct compression depth. An optional 'clicker' signals the correct compression depth
- Realistic chest compression resistance allows the students to experience the amount of pressure needed to perform CPR
- Economical disposable airways for quick and easy clean-up
- Removable and reusable faces for convenient maintenance



AE265 Q CPR Manikin - Light Skin

AE266 Q CPR Manikin - Dark Skin

## Little Junior Q CPR

In addition to the traditional way of using performance metrics to display a score at the end of the session, Little Junior Q CPR can also be used to run Q CPR Race, a completely new and innovative way of engaging learners in CPR training. The competition element makes training more engaging and interactive and has been demonstrated to improve motivation.

Little Junior Q CPR allows an instructor to monitor up to six learners at the same time from the palm of their hand. The Q CPR Instructor App provides an easy to view performance summary that highlights which students may require further guidance.

- Real-time feedback on compressions and ventilations
- Post-training debrief, including overall scores and tips for improvement
- Details on compression release, depth and rate, ventilation volume, and number of compressions, ventilations and cycles



AE1767 Little Junior Q CPR

AE1767.1 Little Junior Q CPR Dark

## Little Baby Q CPR

Little Baby Q CPR is a realistic and affordable BLS manikin for pediatrics. By utilizing gamified learning and objective feedback, Little Baby Q CPR improves training quality, learner engagement, and classroom efficiency.

- Use the one-click-connection to set up training. The Q CPR app guides you through the setup of your classroom.
- With objective feedback on compressions and ventilations, Little Baby Q CPR is future proof. It teaches all the parameters of high-quality CPR as defined by the AHA.
- Choking is one of the biggest reasons for cardiac arrest in infants. Little Baby Q CPR allows learners to practice the not so gentle touch it takes to remove airway obstructions.
- Spot incorrect hand placement with built-in sensors and Q CPR app to instantly adjust learner's performance.
- Practice correct compressions, ventilations, and foreign body removal so that learners act with confidence when it matters the most.



**AE1860** Little Baby Q CPR – Light Skin

**AE1860.1** Little Baby Q CPR – Dark Skin

**AE1860.2** Little Baby Q CPR Lung – 24pk

**AE267.1** Skill Guide

## Resusci Baby with Q CPR

Provides thorough and realistic CPR training. Enhanced measurement of compressions and ventilations allows for comprehensive and accurate guidance. Detailed feedback and debriefing functionalities enables students to learn and improve.

- Realistic anatomy including head tilt, chin lift, compression depth, compression force and chest rise
- Ventilation system provides appropriate chest rise with BVM (Bag Valve Mask) and MTM (Mouth to Mouth)
- Enhanced measurement and feedback
- Detailed debriefing screens
- Sensor indicates correct finger placement

### Compatible with Free Laerdal Q CPR Instructor & Learner Apps

- The instructor app gives a performance overview of up to six manikins, simultaneously. Ensuring effective coaching.
- The learner app allows practice alone. Multiple learners can also use the app to coach each other.



**AE1830** Resusci Baby Q CPR

**AE1831** Resusci Baby Q CPR Airway

**AE267.1** Skill Guide

**AE267.2** SimPad Plus SkillReporter

**AE267.3** Manikin Face Shield – 6 Rolls

**AE267.4** Manikin Wipes (50)

## Resusci Anne Q CPR

Since 1960, Resusci Anne has been the preferred CPR training manikin of healthcare professionals and trained more than 500 million people in critical life saving skills.

Resusci Anne Q CPR manikin and the compatible feedback devices are each designed to be easy to use and require minimal set up time, helping any user focus on quality CPR training.

Built with realistic anatomy and is fully Guideline compliant. As a result, the learner will experience appropriate chest resistance, see chest rise during ventilation and need to perform head tilt, chin lift to ensure an open airway.

- Realistic anatomy including head tilt, chin lift, compression depth, compression force and chest rise
- Sensor indicates correct hand placement
- Ventilation system provides appropriate chest rise with BMV (Bag Valve Mask) and MTM (Mouth to Mouth)
- Enhanced measurement and feedback capabilities
- Wireless connectivity with SimPad SkillReporter or Resusci Anne Wireless SkillReporter software
- Wired connectivity with SkillGuide or SimPad SkillReporter
- Guidelines compliant

**AE268** Resusci Anne Q CPR Torso

**AE268.1** Resusci Anne Q CPR Full Body

**AE268.2** Resusci Anne Q CPR AED, Airway Head Torso

**AE267.1** Skill Guide

**AE267.2** SimPad Plus SkillReporter



## Human Skull Model Bone Coloured

The best selling 3B Scientific® Beauchene Adult Human Skull is a natural cast and makes the complex anatomical structure of the human skull easy to understand. The Beauchene Skull can be disassembled into its 22 individual bones. The individual bones can be reassembled by means of inconspicuous, stable connectors attached at the slightly simplified skull sutures. All 22 bones are depicted in their natural bone colour.

- Parietal bone (L & R)
- Occipital bone
- Frontal bone
- Temporal bone (L & R)
- Sphenoid bone
- Ethmoid bone
- Vomer bone
- Zygomatic bone (L & R)
- Upper jaw (maxilla) with teeth (L & R)
- Palatine bone (L & R)
- Nasal concha (L & R)
- Lacrimal bone (L & R)
- Nasal bone (L & R)
- Lower jaw (mandible) with teeth



**HAN280** Beauchene Adult Human Skull Model Bone Coloured

## Standard Human Skeleton



- Durable, unbreakable plastic
- Life size
- Almost realistic weight of the approx. 200 bones
- 3-part mounted skull
- Individually inserted teeth
- Limbs are quick and easy to remove
- 5 feet roller stand
- Transparent dust cover included
- 3 year warranty
- **Height:** 170cm
- **Weight:** 7.6kg



**HAN047** Standard Human Skeleton

**HAN049** Standard Human Mini-Skeleton 88cm

## Flexible Human Skeleton



- Durable, unbreakable plastic
- Life size
- Almost realistic weight of the approx. 200 bones
- 3-part mounted skull
- Individually inserted teeth
- Limbs are easily and quickly removed from model
- 5 feet roller stand
- Transparent dust cover included
- 3 year warranty
- **Height:** 170cm
- **Weight:** 7.6kg



**HAN069** Flexible Human Skeleton



## Hand Model

A life size model of the hand. The back is dissected to show the superficial vessels, nerves, tendons and muscles. The palm skin is removable, as is the palmar aponeurose and the ligament plate of the superficial tendons.

- The parts are numbered and a key is supplied
- Back is dissected to show the superficial vessels, nerves, tendons and muscles
- Palmar aponeurose & ligament plate of the superficial tendons is removable
- **Size:** 29 x 13 x 7 cm

**HAN001** Hand Model

## Vascular Arm

- Life size model of the left arm and hand in a semi-flexed position with the brachial, radial and ulnar arteries and accompanying veins with their radicals in situ
- The complete circulatory system of the hand is shown on both palmar and dorsal surfaces
- Comparative sizes of the various blood vessels are clearly indicated and facilitate the study of the blood circulation in the arm
- Mounted on stand with key card
- **Size:** 66x18x28cm

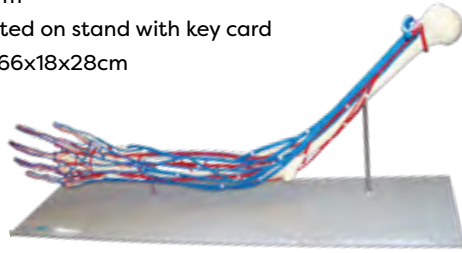

HAN258 Vascular Arm

## Vascular Hand

- Life size model of the left hand in a semi-flexed position with all major veins and arteries depicted
- The circulatory system is shown on both palmar and dorsal surfaces
- Hand can be rotated to allow easy viewing of model from all angles and can be removed if necessary
- Mounted on a stand with key card
- **Size:** 26 x 15 x 22cm

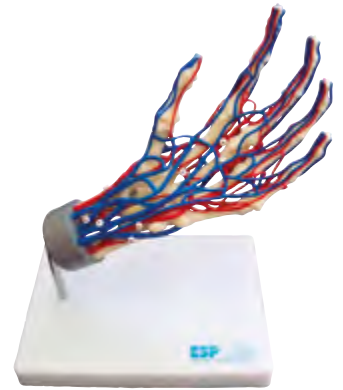

HAN239 Vascular Hand

## Muscular Arm

The following muscles can be removed:

- Deltoid muscles
- Biceps muscle of arm
- Triceps muscle of arm
- Long palmar muscle with radial flexor muscle of wrist
- Brachioradial muscle with radial extensor muscle of wrist

Supplied on base at 70cm & 3kg

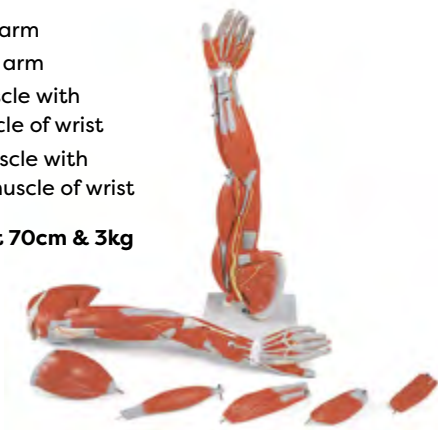

HAN281 Muscular Arm, 6 Part

## Muscular Leg

- Illustrates both the superficial and deeper muscles, eight of which are removable
- Tendons, vessels, nerves and bone components of the left leg and foot are shown in great detail
- All parts are numbered
- Supplied on removable stand
- **Dimensions:** 77 x 26 x 26cm
- **Weight:** 4kg



HAN123 Muscular Leg, 9 part

## Complete Dual Sex Muscular Figure

The complete human anatomy in a convenient size. This compact figure is the perfect choice for thorough demonstrations of human musculature and internal organs.

Complete with 33 removable parts which include the following:

- 5 arm/shoulder muscles
- 8 leg/hip muscles
- 2-part heart
- 2-part brain
- 2 lungs
- 2-part male and 2-part female genital inserts
- 2-part intestine system
- Detachable breast/belly covering and arms for detailed study
- Almost 400 hand-numbered and identified structures
- Painted by hand in realistic colours
- Supplied with stand and detailed multilingual product manual
- **Dimensions:** 84 x 30 x 30cm
- **Weight:** 5.5kg

HAN125 Complete Dual Sex Muscular Figure, 33 part with organs

HAN282 Muscular Figure, 1/3 Lifesize, 2-part

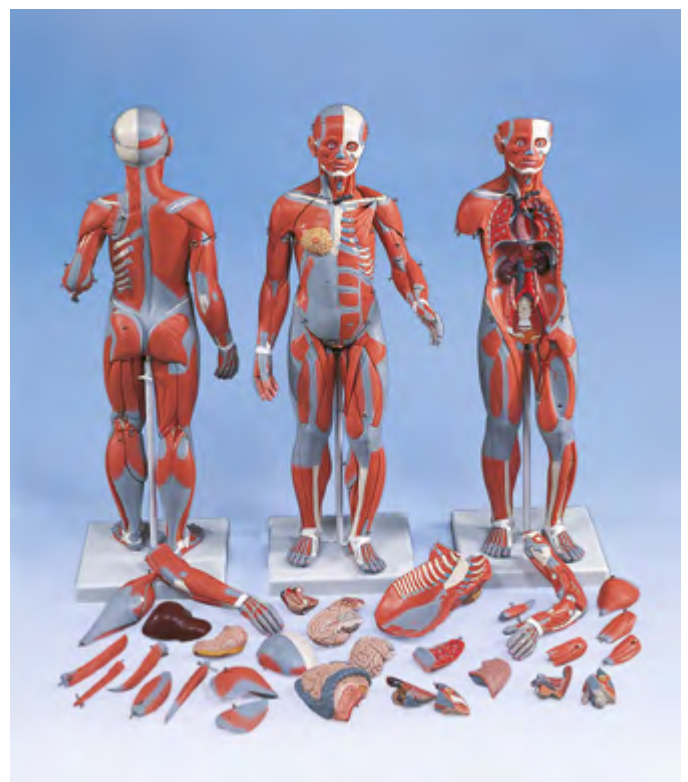

## Heart Models

### Heart Model, 2 part

- Highly detailed 2-part heart
- The front heart wall is detachable to reveal the chambers and valves inside the human heart
- Heart just slightly smaller than life-size with exquisite anatomical detail
- Great model of the anatomy of the human heart on a stand



HAN097 Heart Model, 2 part

### Heart Model with Bypass, 4 part

- 2 times life size makes it easy to see even in large lecture halls.
- Front heart wall removable to view chambers and internal structures
- In addition to the anatomy of the heart, this heart model shows a venal bypass
- Supplied on removable stand



HAN122 Heart Model with Bypass, 4 part

### Heart Model with oesophagus & trachea, 5 parts

- 2 times life size makes it easy to see even in large lecture halls.
- Atrium wall & front heart wall removable to reveal realistic details
- Hand painted in lifelike colour
- Supplied on removable stand



HAN098 Heart Model, 5 part

## Head Models

### Head with Neck Model, 4 part

- The left half of this life-size model in midsagittal section shows the muscles, with nerves, vessels and bony structures and contains a removable brain half
- The head is mounted on a detachable neck part which is sectioned both horizontally and diagonally
- Supplied on baseboard
- **Size:** 26cm, 2.2kg



HAN128 Head with Neck Model, 4 part

### Head and Neck Musculature, 5 part

- Representation of the superficial musculature and deep muscles, nerves and vessels
- Dissectible into skull cap and a 3-part brain
- Supplied on removable baseboard
- **Size:** 36 x 18 x 18cm, 1.8kg



HAN130 Head and Neck Musculature, 5 part

### Head Model, 6 part

- Life-size 6-part head model
- One side exposes the nose, mouth cavity, pharynx, occiput and skull base
- Features a removable 4-part brain half with arteries
- Eyeball with optic nerve is also removable
- On removable base
- **Size:** 19 x 23 x 22cm, 1kg



HAN129 Head Model, 6 part

## Respiratory Organs

- Strong material, coloured to show major anatomical details
- The diaphragm shows muscles, tendons and openings for the major vessels and oesophagus
- The aorta shows the origins of five abdominal arteries
- Three thoracic and three lumbar vertebrae are shown
- The left lung is sectioned to expose the bronchioles, pulmonary arteries and veins
- The heart is bisectable to expose the atria and ventricles, and shows the superior and inferior vena cava, aorta, pulmonary artery and the coronary sinus
- Supplied complete on stand, at 41 x 23 x 19cm

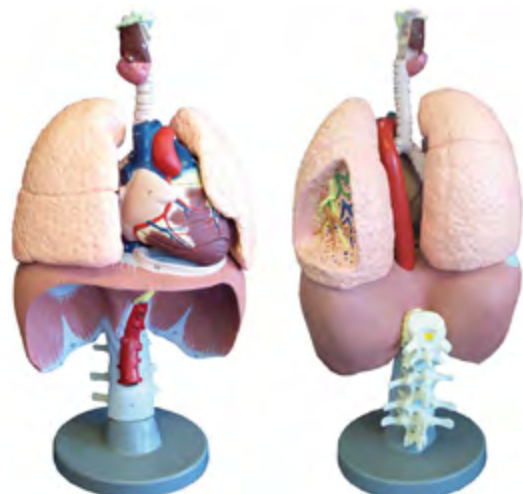

HAN270 Respiratory Organs

## Pregnancy Models

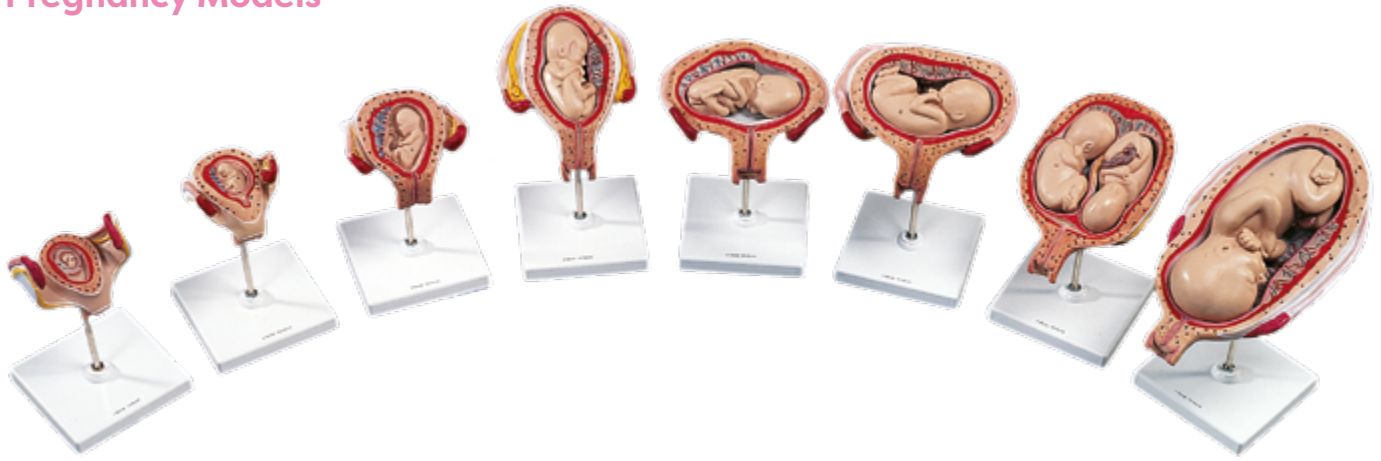

- Each model is mounted on a separate stand
- Available as a complete set or individually
- Each model shows each stage of development

**HAN105** 1st Month Embryo Pregnancy Model

**HAN106** 2nd Month Embryo Pregnancy Model

**HAN107** 3rd Month Foetus Pregnancy Model

**HAN108** 4th Month Foetus, transverse lie, Pregnancy Model

**HAN104** Pregnancy Series (complete)

**HAN109** 5th Month Foetus, breech position, Pregnancy model

**HAN110** Pregnancy Model, 5th Month Foetus, transverse lie

**HAN111** Pregnancy Model, 5th Month Twin, normal position

**HAN112** Pregnancy Model, 7th Month Foetus

## Cervix Examination Set

A model of the external female genitalia manufactured from a soft, lifelike plastic, with a set of six interchangeable cervix simulations

- The cervix simulations are inserted into the model to allow the student to practice measuring the cervix prior to birth
- The stages are no dilatation, 2cm dilatation with 50% effacement, then 2cm, 5cm, 7cm, & 9cm with full effacement
- Because of the lifelike nature of the materials used, the model should be treated with the care accorded to a real subject
- Supplied with teaching notes in a plastic carry case

**HAN268** Cervix Examination Set



**HAN254**



**HAN257**



**HAN256**

## Female Pelvis Models

### Articulated Pelvis

- Life size articulated pelvis with 5th lumbar vertebra
- Ideally suited for midwifery studies in conjunction with our foetal dolls
- It is made in our realistic bone-like material and can be articulated into 4 parts

### Ligamented Pelvis

- Life size pelvis with 5th lumbar vertebra and ligaments
- Cannot be disarticulated and is made in our realistic bone-like material

### Pelvis, Floor, Nerves & Ligaments

- A life size bony female pelvis showing the ligaments and the main nerves, with a removable 2 part pelvic floor

**HAN254** Articulated Pelvis, Female

**HAN256** Ligamented Pelvis, Female

**HAN257** Pelvis, Floor, Nerves & Ligaments

## Epidural and Spinal Injection Trainer

Extremely realistic haptic feedback, and the use of high-quality, hard-wearing materials. Thanks to close cooperation with epidural anesthesia specialists, incomparably realistic conditions could be recreated.

The light, compact structure can be used in a wide variety of ways. The device has low operating costs and is intuitive to use, ensuring lasting, high-level performance.

- Epidural anaesthesia using the loss-of-resistance and the hanging-drop technique
- Spinal anaesthesia with realistic resistance of the dura and arachnoid mater with or without a cannula
- Fluid-filled spinal canal with realistic outflow rate thanks to the ability to adjust the excess pressure
- An epidural catheter can be inserted into the epidural space
- Closed water system and easy to clean



**HAN334** Epidural and Spinal Injection Trainer

## I.V. Training Models

### I.V. Training Arm

Detailed exercises in venipuncture can be mastered on a realistic model before administration to live patients. Demonstrate sterile technique, sharps injury protection, taping and securing techniques, and infusion or withdrawal procedures.

**Features include:** lifelike vein roll-over, durable for repeated use, palpation of vein for location. Characteristic “pop” can be felt when needle penetrates vein.

**Supplied with a tray and simulated blood**



**HAN006** I.V. Training Arm

### I.V. Training Hand

Designed for practise in giving IVs by permitting detailed exercises in venipuncture so that the technique can be mastered on a realistic model before administering to patients.

**Features include:** lifelike vein roll-over, durable for repeated use, palpation of vein for location. Blood can be withdrawn or fluid injected. Characteristic “pop” can be felt when needle penetrates vein.

**Supplied with a tray and simulated blood**



**HAN007** I.V. Training Hand

## Injection Arm with Hand

- Ideal for medical training purposes – Students, Nurses, etc.
- The veins are shown in detail
- Can be used for training in drawing blood, intravenous injections & infusion techniques
- The skin is made from plastic selected to allow natural palpation of the veins



**HAN008** Injection Arm with Hand

## Prostate Model 1/2 natural size

- Cross section of the male genital organs
- Shows healthy prostate, bladder, urethra, testicle, symphysis and rectum
- Narrowing of the urethra due to the change of the prostate is shown via the 4 cross sectional views
- All painted in detail
- Supplied on base
- **Size:** 13.5 x 10 x 14cm



**HAN103** Prostate Model 1/2 natural size



## Airway Management Trainer

- Anatomical landmarks including sternum and ribcage plus substernal notch
- The manikin contains teeth, uvula, vocal cords, glottis, epiglottis, larynx, arytenoid cartilage and trachea
- Other features include esophagus and inflatable lungs and stomach, n.g. tube placement, bag valve mask ventilation
- Soft carry bag included

**Dimensions:** 165 x 58 x 23cm



**HAN183** Airway Management Trainer Torso

**HAN184** Airway Management Trainer Full Body

## Critical Airway Management Trainer

Very difficult intubation head, coupled with CPR torso, supplies the challenges for initiating respiratory care to critical patient.

By using the features of tongue swelling and laryngospasm, the instructor creates a critical airway management problem that requires the student to perform a cricothyrotomy.

- Tongue Swelling and Laryngospasm
- Two external/ One internal bleeding wounds
- **Dimensions:** 69 x 43 x 25cm



**HAN185** Critical Airway Management Trainer

## Child Airway Management Trainers

### Child Trainer 5 year old Head

Simulated head of 5-year-old featuring realistic size and anatomy. Perfect for practising airway management skills on paediatric patients.

Realistic anatomy: mouth, tongue, oral pharynx, larynx, epiglottis, vocal cords, trachea, and esophagus. Separate lungs for auscultation. Inflatable stomach bladder indicates esophageal insufflation.

### Child Airway Management Trainer – Torso

This torso is designed to be the foundation of the Child CRISis system as arms, legs, and a defibrillation chest skin can be added later to provide IV access, intraosseous infusions, blood pressure monitoring, and ECG recognition and defibrillation training. Includes a range of landmarks.



**HAN188**

All models include pump lubricants



**HAN187**

**HAN186** Child Trainer 5 year old (without stand)

**HAN187** Child Trainer 5 year old (with stand)

**HAN188** Child Airway Management Trainer – Torso

## Complete ALS Trainer

Features allow for: airway maintenance with Endotracheal (ET) tubes, Oropharyngeal Airways (OPA), Nasopharyngeal Airways (NPA), Combitubes, and other adjuncts; IV catheterisations in the lower arm; ECG pattern recognition using the Interactive ECG rhythm generator; and CPR. Suitable for practicing defibrillation with full joule level discharge performed via patient care devices.

Anatomical landmarks include the sternum, rib cage, and substernal notch. The trainer contains teeth, uvula, vocal cords, glottis, epiglottis, larynx, arytenoids cartilage, trachea, esophagus, and inflatable lungs and stomach.

- Bag valve mask ventilation
- Delivery of supplemental oxygen
- Palpation of carotid pulse
- ABC assessment
- Separate right and left lungs
- Auscultation of air movement
- Chest compressions and precordial thump
- Jaw thrust
- IV sites in hand and arm for venepuncture
- Intramuscular injection site
- Blood pressure cuff placement
- Rhythm recognition featuring 17 rhythms



Full body trainer includes pelvis and legs and allows for the practise of patient movement.

**HAN161** Complete ALS Torso with Carry Bag

**HAN162** Complete ALS Full Body Trainer with Carry Bag

**HAN163** Face Shield Bags

**HAN164** Replacement Lung/Stomach (pack of 3)

**HAN165** Intramuscular Injection Pads (pack of 3)

**HAN166** Replacement IV Veins

**HAN167** Replacement IV Skin

## KERi™ Life/Form Manikin

The Complete KERi™ Manikin includes the following features:

- Lightweight – approximately 28 lbs.
- Full-size adult manikin – measures 58”
- Overall female appearance (wig/genitals to convert to male)

### Patient Care Simulation:

- Bandaging and Wound Dressing
- Denture Placement and Removal, Upper and Lower
- Ear Canal Irrigation, Otic Drops, and Hearing Aid Placement
- Finger and Toe Manipulation with Bandaging
- Urinary Catheterisation, Female and Uncircumcised Male
- Intramuscular Injection Sites: Arm, Thigh, Buttock
- Oral and Nasal Hygiene: Lavage, Gavage, and Suctioning
- Ostomy Care: Ileostomy and Colostomy Tissue
- Tracheostomy Care, Lavage and Suctioning
- Gastrostomy Procedures, Lavage and Gavage
- Patient Positioning/Transfer Techniques
- Enema Administration, Female Only
- Pap Smears and Douching
- Prostate Exam, Stage B
- Nasogastric Tube Placement
- Internal Fluid Reservoirs
- and many more uses...

### Visual Inspection:

- Normal and Cancerous Mole
- Stage 1 Sacral Ulcer
- Dilated and Constricted pupils
- Reddened Skin Folds



**HAN275** Complete KERi Nursing Skills Life/Form Manikin

## Auscultation Trainer

- Students must palpate to correctly identify auscultation locations
- Manikin presents as a patient, without visible auscultation sites
- The instructor changes the lung and heart sounds by using the wireless remote control as the scenario progresses
- 10 posterior, 5 anterior and 2 midaxillary lung sound sites and six anterior heart sound locations
- The students will hear different heart and lung sounds as they move the Smartscope™ to different locations on the manikin
- One remote control will command multiple units of Smartscope™ and/or manikin's up to one hundred feet away, a great advantage in group training sessions
- A speaker jack is included on the Smartscope™ with single- and dual-user headpieces
- Includes a hard carry case, batteries for remote & Smartscope



**HAN195** Auscultation trainer and Smartscope

**HAN196** Additional Smartscope

**HAN197** Additional Body

**HAN198** Auscultation Practice Board with Case & Smartscope

**HAN199** Auscultation Trainer, Practice Board & Smartscope

**HAN200** Auscultation Board with Case only

## Defibrillation CPR Training Manikin

For demo and practice of defibrillation and CPR training

- **Comes complete with:** load box, arrhythmia simulator box, CPR Adam manikin with defibrillation skin, 10 disposable lung/airway systems, 10 mouth/nosepieces, and a soft carry case.
- Functions with manual, semi-auto, and auto defibrillators
- Provides helpful, realistic training with full CPR capabilities
- The arrhythmia/pacing simulator recreates 17 adult heart rhythms and 17 paediatric rhythms
- With an external pacer, you can simulate electronic capture
- You can also simulate cardioversion with manual, semi-automatic, or automatic defibrillation
- **Dimensions:** 79 x 46 x 25cm

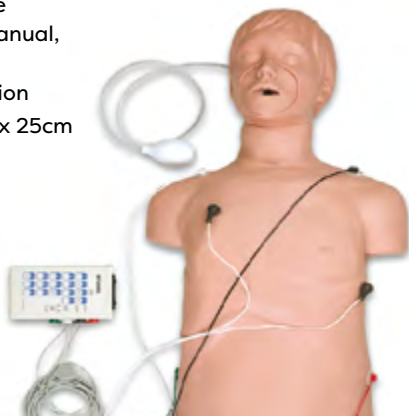

**HAN168** Defibrillation CPR Training Manikin with Carry Bag

**HAN169** Zoll Training Lead

**HAN171** Medtronic Physio

## Bariatric CPR Fred Manikin

Formerly known as 'Fat Old Fred' it is a realistic size and has the appearance of an elderly and overweight patient. Features also include accurate anatomical landmarks allowing for the proper application of CPR techniques.

The Bariatric CPR FRED Manikin is the only obese CPR manikin on the market and helps prepare students for responding to a more typical cardiac arrest event with a patient who is elderly and overweight.

- A realistic head tilt and chin lift for opening the airway
- Palpable, visual anatomical landmarks that include the sternum, rib cage, and substernal notch.
- Elderly physical appearance
- Large body type with extra fat layer
- The airway can be easily manipulated to simulate airway obstruction or choking situations.
- Economical, individual use mouth/nose pieces
- User-friendly airway/lung system with a non-re-breathing valve for a safer, hygienic training experience.



**HAN274** Large Bariatric CPR Fred Manikin

## Tracheostomy Care Manikins

- Ideal for teaching patients and caregivers the skills they will need to perform at home
- The Adult Manikin includes oral and nasal passages, the pharynx, epiglottis, trachea, esophagus, tracheostomy site and cricoid cartilage
- The mouth and jaw are flexible to allow oral suctioning
- The trachea branches into the left and right bronchial trees
- Students can practice suctioning techniques, proper cuff inflation, dressing changes and other techniques
- Cleansing and maintenance of the external tracheal site can be performed just as on an actual patient
- Infant Manikin can be used to teach parents and caregivers basic tracheostomy care skills and is used extensively with children to comfort them and improve their self-esteem

**Complete with:** one adult and one infant manikin, one adult and one infant tracheostomy tube, instruction guide and hard case



**HAN212** Life/form Patient Education Tracheostomy Care Set

**HAN213** Life/form Adult Tracheostomy Care Manikin

**HAN214** Life/form Infant Tracheostomy Care Manikin

**HAN211** Life/form Tracheostomy Care Simulator

## Blood Pressure Simulator

- **Features include:** redesigned and durable control unit, Radial Pulse, simple calibration procedure, optional external speaker
- Allows the preset of values for both systolic & diastolic pressures
- Provides an excellent means to practice listening to and distinguishing blood pressure sounds prior to clinical tests
- It is possible to audibly discern the five Korotkoff phases
- Student can find the preset results and the instructor can unfailingly know if the procedure was performed accurately
- The electronically generated sounds are digitally recorded
- Control unit allows instructors to select systolic and diastolic settings, adjust pulse rate, adjust volume, turn auscultatory gap on or off, easily calibrate unit for use with any sphygmomanometer

**Includes:** Arm with speaker; sphygmomanometer; electronic control unit; batteries; instructions and hard carrying case.



**HAN218** Life/form Blood Pressure Simulator

**HAN219** Life/form Deluxe BP Simulator with Speaker System

## Sigmoidoscope Exam Simulator

- As the scope follows the contours of the large intestine, the student must negotiate the sigmoid colon, splenic flexure and hepatic flexure before viewing the internal structure of the ascending colon and cecum
- As the flexible sigmoidoscope is withdrawn, the student can begin to identify benign sessile, pedunculated and hyperplastic polyps
- There are a total of 12 pathological conditions to diagnose
- All manipulative and photographic techniques can be practiced on this simulator
- Originally produced exclusively for ACMI, this simulator has been used for physician training nationwide
- Supplied mounted on an oak stand with lubricant, guide and carry case



**HAN229** Life/form Sigmoidoscope Examination Simulator

## Prostate Examination Simulator

**An indispensable model for both students and professionals.**

- Now every student can learn to detect beginning stages of prostate cancer and increase chances of patient survival
- Four separate prostate glands are supplied with the torso, representing one benign gland and three stages of prostatic carcinoma in varying degrees of development
- Each gland can be inserted into the prostate torso to allow realistic practice in diagnosis by rectal palpation
- Complete with four glands, hard carrying case, lubricant, cleaner and teaching guide

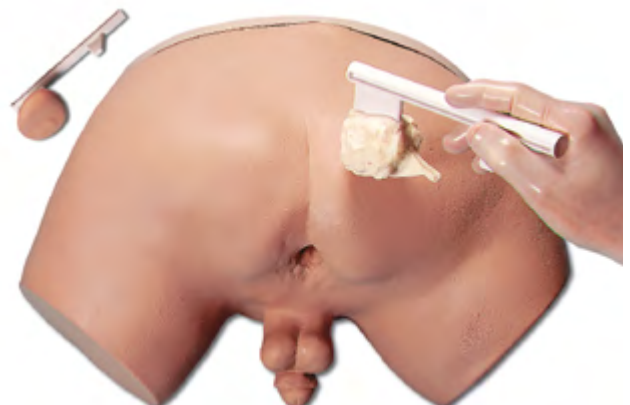

**HAN232** Life/form Prostate Examination Simulator

**HAN233** Lubricant Kit - Pack of 6

## Forceps/Vacuum Delivery Manikin

- Has all of the same realistic and accurate anatomical manikin features as in the Obstetrical Manikin (HAN221), but with added features of premature and full term fetuses
- The soft vinyl pelvis replicates resistance encountered in a delivery requiring forceps or vacuum intervention
- The removable abdominal overlay provided with this manikin is different from those that come with the HAN221, but the overlays are interchangeable and optional
- Includes: powder to make simulated blood, extra vulva and soft carry bag. **Forceps & Vacuum Extractor not included**



**HAN220** Forceps/Vacuum Delivery OB Manikin with Carry Bag

## Obstetrical Manikin

- An anatomically correct pelvic model with full term newborn and placenta to give trainees practice in emergency childbirth
- The lifelike pelvic cavity has pronounced pelvic landmarks, located spinal column, angled birth canal, ileum, ischium, sacrum, sacro spinous ligaments and greater sciatic notch
- Disposable umbilical cords with clamps, easily replaceable extra vulva, powder to make simulated blood, a modular pregnant belly overlay with permanently installed fetus for training practice of the Leopold's maneuver to determine the fetus' lie by palpating its skull and kneecaps and a clear abdominal overlay to see positioning are all included



**HAN221** Obstetrical Manikin with Carry Bag

**HAN222** Obstetrical Manikin African-American with Carry Bag

## Xtreme Trauma Wound Kit

Contains 12 life-like wounds plus all the accessories you need for preparing a victim for training. Wounds can be used on manikins or humans and many can be made to bleed. Wounds are easily cleaned and can be reused many times.

- |   |                               |
|---|-------------------------------|
| • 1x Tongue Depressor/ spatula Combo    | • 3x Spirit Gum - 1oz w/brush |
| • 1x Red Grease Paint - 2oz             | • 1x Broken Lower Arm         |
| • 1x White Grease Paint - 2oz           | • 1x Chest Wound              |
| • 1x Brown Grease Paint - 2oz           | • 1x Eye & Face Wound         |
| • 1x Blue Grease Paint - 2oz            | • 1x Hand Wound Large         |
| • 1x Casualty Simulation Wax - 8oz      | • 1x Hand Wound Small         |
| • 3x Blood Powder Packet for one gallon | • 1x Broken Upper Arm         |
| • 1x Coagulant Blood - 4 oz             | • 1x Jaw Wound                |
| • 1x Methyl Cellulose as Blood          | • 1x Head Wound               |
| • 1x Broken Glass                       | • 1x Burned Face              |
|   | • 1x Lower Leg Wound          |
|   | • 1x Upper Leg Wound          |
|   | • 1x Broken Ankle             |



Each item is available separately - contact us for details

**HAN278** Xtreme Trauma Wound Kit

## Nursing Care Wound Kit

This moulage kit offers a variety of disease, pressure and surgically induced wounds to assist practitioners in understanding the treatment of their patients. The kit comes with a spray container of both stinky sweat and vomit to assist in presentation. Supplied in a protective carry case.

- |                                 |  |
|---------------------------------|--|
| • Child Colostomy               | • Stage 1 Ulcer  |
| • Adult Stoma                   | • Barf Spray   |
| • 2nd Degree Burn               | • Stinky Sweat Spray   |
| • Large Road Rash               |  |
| • 6" Skin Graft                 | Moulages include one each of the following that can be ordered separately: |
| • Ankle Edema - 2 each          | • 3 Spirit gum with applicator   |
| • Surgical Site Infection Lvl 1 | • 1 Coagulant Blood 4 oz.  |
| • Surgical Site Infection Lvl 2 | • 12 adhesive removal wipes  |
| • Surgical Site Infection Lvl 3 |  |
| • 4th Stage Bed Sore 70mm       |  |
| • 20mm Diabetic Ulcer           |  |



Each item is available separately - contact us for details

**HAN279** Nursing Care Wound Kit

## Genius™ 3 Tympanic Thermometer

Count on the Genius™ 3 to deliver accurate readings

- Peak Select technology takes multiple readings and selects the highest temperature for display in 1 to 2 seconds.
- Rugged tip-based sensor construction improves durability, minimizing the need for recalibration.
- Disposable probe covers help prevent cross-contamination.
- Programmable display shows oral, rectal, or an absolute temperature reading in ear mode.
- Redesigned plastic housing allows for an IP22 rating for protection against dust and liquid ingress.

**HEL380** Genius™ 3 Tympanic Thermometer

**HEL348** Probe Covers For Genius™ 3 – 96pk



Compliant with Standards

- ISO 80601-2-56:2017
- IEC 60601-1-2:2014
- IEC 60601-1:2005/AMD1:2012
- IEC 60601-1-11:2015 Ed.2



D

Thermometers

## Welch Allyn® Braun Pro6000 Ear Thermometer

- For medical professionals who demand the most accurate, clinically tested, non-invasive temperature measurements.
- ExacTemp™ technology detects stability of probe during use
- Quick, accurate readings may improve patient satisfaction
- Easily switch between Celsius and Fahrenheit
- Soft probe covers keep probe tip clean for accuracy
- Takes approximately 1,000 readings on two AA batteries

Why professionals choose the unique Pro6000 thermometer:

- Hospital-grade thermometer with calibration down to 20°C
- Innovative PerfecTemp technology adjusts for variability in the probe placement
- Durable enough for demanding medical environments
- Several security features and options help prevent theft

**HEL044** Welch Allyn® 1.8m security tether

**HEL045** Welch Allyn® 2.7m security tether

**HEL079.1** Braun Probe Covers – 200pk



**HELO40**



**HELO41**



**HELO40** Pro6000 with small cradle

**HELO41** Pro6000 with large cradle

**HELO43** Pro6000 with large cradle & charging station

## Welch Allyn® SureTemp™ Plus

- Includes convenient storage for 25 probe covers
- Large LCD displays temperatures in Fahrenheit or Celsius
- Last temperature recall
- Convenient storage for 25 probe covers
- Takes approximately 6,000 readings on 3 AA batteries

**HEL114** Wall Mounted with Alarm & 4ft Oral Probe

**HEL114.1** Wall Mounted with Alarm & 9ft Oral Probe



## Omron Gentle Temp 521

New, user-friendly ergonomic design for extra comfort, especially suitable for use with youngsters. Convenient backlit display and infrared technology provide results in one second, so that highly accurate measurements can be taken with the minimum of fuss.

Can be used to take ear temperature and also surface temperatures, from a milk bottle or food dispenser for example.

- 3 in 1 measurement
- 1 Second measurement
- Stores 25 readings
- Large backlight display
- 21 probe covers included
- Displays Celsius/Fahrenheit
- Automatic shut off
- **Size:** 36 x 161 x 56 mm
- **Weight:** Approx. 85g
- **Supplied with:** Test Battery, Probe Cap, 21 Probe Covers, Connection Ring and Guide



**HEL369** Omron Gentle Temp 521

**HEL368.1** Probe Covers for Omron Gentle Temp 520/521 (pack of 40)

## Omron Gentle Temp 520

Highly accurate thermometer with advanced features, including one second measurement and a memory for up to nine readings. It also comes with 21 probe covers and can display temperatures the large LCD display in either degrees centigrade or fahrenheit.

- 1 Second measurement
- Stores up to 9 readings
- 21 probe covers included
- Readings in Celsius / Fahrenheit
- Outer Dimensions: 36 x 161 x 56mm
- Weight: Approx. 85g
- **Supplied with:** Test Battery, Probe Cap, 21 Probe Covers, Connection Ring and Instruction Manual



**HEL368** Omron Gentle Temp 520

**HEL368.1** Probe Covers for Omron Gentle Temp 520/521 (pack of 40)

## Omron Gentle Temp 720

Omron's first digital forehead thermometer. It uses highly accurate technology and has advanced features such as one-second measurement, selectable Centigrade/ Fahrenheit readings and room temperature display.

It features Omron's 3-in-1 function that gives you the measurement of the temperature of the room as well as surface temperature.

### At a glance:

- 3 in 1 measurements
- Very fast 1 second measurement
- Backlight function
- Selectable Celsius/Fahrenheit
- Automatic shut off



**HEL374** Omron Gentle Temp 720 Infrared Thermometer

## TH03F Forehead Thermometer

- Compact and ergonomic design for home or travelling use
- Temperature measurement is conducted without contact with the skin - by holding 1cm from the forehead
- Large LCD display for easy reading & low power consumption
- Large, easy-to-read LCD display
- Provides a low fever alarm to assist in temperature taking
- The device holds up to nine readings
- Conforms to ASTM accuracy standards
- Dual Scale (Celsius or Fahrenheit)



**HEL145** TH03F Forehead Thermometer

## Braun Thermoscan 7 IRT Thermometers

- No.1 brand used and recommended by doctors\*
- Age Precision® technology - age-adjustable fever guidance
- Colour-coded display for easier interpretation of results
- Wide-angle probe for accurate measurements, incl. newborns
- Pre-warmed tip to ensure reliable measurements
- ExacTemp® technology to ensure stable positioning of the device before taking a measurement
- Fast, gentle and easy
- Backlit display for use in dark environments
- Stores the last 9 temperature readings



**HEL021** Braun Thermoscan 7 IRT6520 Thermometer

**HEL020.3** Battery for Braun Pro4000 / Thermoscan Devices

**HEL079.1** Braun Probe Covers - 200pk

## Omron EcoTemp Basic Thermometer

EcoTemp are neatly designed and have a simple concept developed for use in various settings. The easy-to-use placement of the ON/OFF button and the simple sleek design reinforces the high-quality recognition.

- Memory (last measurement value)
- Exchangeable battery
- 3-digit display (1 decimal place)
- Water-resistant with a Beeper



**HEL180** Omron EcoTemp Basic

## Omron Flex Temp Smart

A 10 second thermometer for quick and fast measurement with the added advantage of a flexible tip for further comfort.

- Digital Fever Thermometer for Oral, Axillary and Rectal use
- Memory (last measurement value)
- C/F indication with 3-digit display
- Exchangeable battery
- Water-resistant



**HEL118** Omron Flex Temp Smart Thermometer

## ACCOSON Non-contact Thermometer

Further to its reliability, accuracy, and easy handling, this thermometer allows gentle and non-invasive measurement of body temperature without touching the patient.

- Touch-free measurement
- Fast and gentle measurement in only 3 seconds.
- 30 data memory (stored with date/time)
- Multifunctional use (body, object and ambient temperature)
- A blue LED indicates correct measurement area and distance
- Silent Glow™ – red light shows if temperatures exceed 37.4°C
- Sound control (on/off) – Silent operation for use at night.

**HEL373.1** ACCOSON Non-contact Thermometer



ACCOSON



## ri-thermo® sensioPRO+ Infrared Thermometer

Non-contact, clinical grade, infrared forehead thermometer with optional Bluetooth® connectivity. Perfect for when speed and minimising cross contamination has never been so critical.

- Clinical grade readings in 1-2 seconds
- Applicable for all patient types
- Minimum of 3000 measurements with one set of AA batteries
- LCD Backlight display for low light situations
- Measuring distance of approx. 3-7 cm
- Switchable from Celsius to Fahrenheit
- CE / FDA approved
- **Dimension / Weight:** 150 x 48.5 x 55mm (LxWxH) / 125.8g



Riester

**HEL384.3** ri-thermo® sensioPRO+ with Bluetooth

**HEL384.1** ri-thermo® sensioPRO+ w/o Bluetooth

**HEL384.2** Calibration kit for ri-thermo® thermometers

## ri-thermo® tymPRO+ Tympanic Thermometer

Clinical grade, tympanic forehead thermometer with optional Bluetooth® connectivity.

- Clinical grade readings in 1 - 2 seconds
- Guide indicator to ensure proper probe tip placement
- Applicable for all patient types
- Single use, latex and BPA free disposable probe covers aid prevention of cross infection with contactless one hand use
- Minimum of 3000 measurements with one set of AA batteries
- CE / FDA approved
- **Dimension / Weight:** 150 x 42 x 56mm (LxWxH) / 80 g



Riester

**HEL385** ri-thermo® tymPRO+ with Bluetooth

**HEL385.1** ri-thermo® tymPRO+ w/o Bluetooth

**HEL385.3** Probe cover for tymPRO+ (300 Pack) 30x 10 piece

**HEL384.2** Calibration kit for ri-thermo® thermometers

## ri-thermo® fastPRObe Thermometer

Professional electronic thermometer for quick and accurate body temperature measurements. Designed for professional use in the daily routine. Support for oral, rectal and axillary measurements.

- Fast and reliable spot-check measurements
- Backlight illuminated and easy to read LCD screen
- Colour coded probes distinguish between oral/axillary (blue) and rectal (red), probe covers to reduce risk of cross infection
- 1000 + measurements with one set of batteries
- Switchable from Celsius to Fahrenheit with auto on/off
- **Dimensions / Weight:** 70 x 70 x 205 mm (LxWxH) / 400 g

**HEL386** ri-thermo® fastPRObe – Blue (oral, axillary)

**HEL386.1** ri-thermo® fastPRObe – Red (rectal)

**HEL386.2** Thermometer probe insert – Blue (oral, axillary)

**HEL386.3** Thermometer probe insert – Red (rectal)



Riester



**HEL386.5** Probe cover package (500 Pack) 25x 20 piece

## Titmus V4 with Carry Case

A precision-built vision tester designed to provide accurate and reliable vision screening for occupational health professionals. The Titmus V4 provides a comprehensive range of eye tests and features that can minimise consultation times, improve workflows, help with record keeping, and deliver comprehensive patient results.

The vision tester allows for the following vision screening exams: visual acuity (near, far and optional intermediate), depth perception, colour perception, lateral and vertical phoria, and peripheral tests. Night vision tests are also available should screening programmes require.

- Compact and portable
- Ergonomic design
- Head sensor for accurate head positioning
- Remote control panel
- True colour testing
- Comprehensive range of test parameters
- No calibration required
- Ideal for industrial and DSE screening needs
- **Dimensions:** 28 x 43 x 19 cm (in closed condition)
- **Weight:** 6 kg



HLO109 Titmus V4 with Carry Case

## Visiolite Master Vision Testers

PC operated vision testers designed to provide fast and accurate vision assessments with fully customisable test routines and automated data management. The Visiolite Master and Visiolite Master GT provide significant improvements in both workflow and time management.

Both testers can be easily connected and operated via a PC. With data management features such as automatic PDF generation and specific test routines, administration and test times can be significantly reduced, allowing for complete patient focus.

The Visiolite enables user defined test parameters to be selected, as well as configuration of the test sequence parameters to suit the needs of the programme. The following user defined screening parameters are provided: acuity test (near, far and intermediate), colour vision, depth perception, contrast sensitivity, vertical and horizontal phorias, fusion, astigmatism, horizontal and vertical peripheral visual fields.

The Visiolite Master GT also has the capability to perform glare sensitivity, resistance testing and Amsler grid.

- PC operated or remote-controlled
- Customisable patient instructions
- Time-saving user defined test routines
- Horizontal and vertical peripheral field tests
- EMR connectivity
- Glare sensitivity and resistance (Visiolite Master GT only)



HLO228 Visiolite Master Vision Tester with Case

HLO228.1 Visiolite Master GT Vision Tester with Case